

Index

Rod Seals

Piston Seals

Wipers

Wear Rings

Static Seals

Materials



ARTIC SEALS™

Oleodinamica/Pneumatica
Hydraulic/Pneumatic



www.gapigroup.com



Gapi Group

Nato nel 1962, GAPI Group ha sede in Italia, a Castelli Calepio, Bergamo.

Specializzato nella realizzazione, distribuzione e vendita di una gamma completa di **soluzioni di tenuta**, GAPI Group oltrepassa i 100 milioni di Euro di fatturato annuo e impiega oltre 700 addetti distribuiti su 12 siti produttivi e 6 unità logistiche.

Grazie al coordinamento di **11 divisioni interne** specializzate nella progettazione e realizzazione di differenti articoli tecnici in materiali quali gomma, gomma metallo, termoplastici, poliuretani, PTFE e tecnopolimeri, e alla disponibilità di differenti tecnologie produttive, di sofisticati laboratori di analisi e centri di ricerca e sviluppo, GAPI Group è in grado di offrire soluzioni per tutte le principali esigenze applicative con un concetto di **total sealing**.

Established in 1962, the GAPI Group is based in Castelli Calepio, Bergamo, Italy.

*GAPI Group specializes in the manufacturing, distribution and sale of a complete range of **sealing solutions**. The group has an annual turnover of more than 100 million Euros and employs over 700 people, working in **11 production plants** and 6 logistical facilities.*

Ten divisions coordinate the design and manufacture of technical products in rubber, rubber-metal, thermoplastics, polyurethanes, PTFE and other technical polymers. R&D centres support the diversified manufacturing technologies with vanguard analysis, and product and material development laboratories.

*Through the business concept of "**Total Sealing**", the GAPI Group provides value by offering a broad range of technical solutions through localized logistical support and service.*



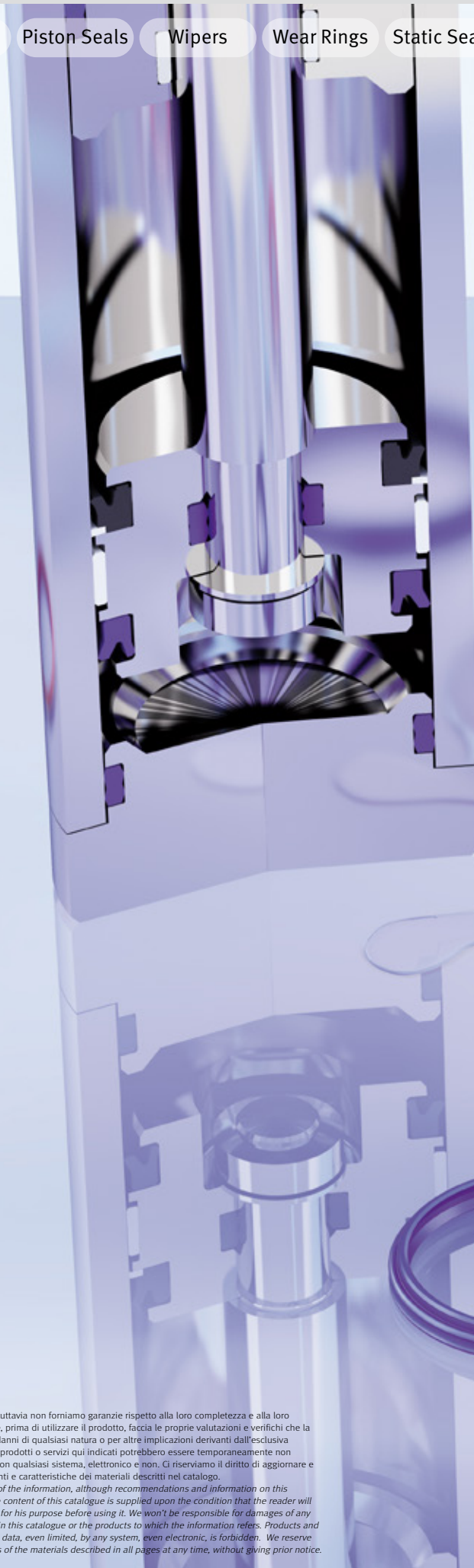

COPYRIGHT © 2020 GAPI MARKETING COMMUNICATIONS DEPT.

Le informazioni di questo catalogo sono ritenute affidabili e fornite in buona fede, tuttavia non forniamo garanzie rispetto alla loro completezza e alla loro precisione. Il contenuto del catalogo rimane infatti valido a condizione che il lettore, prima di utilizzare il prodotto, faccia le proprie valutazioni e verifichi che la soluzione scelta sia idonea allo scopo. Non ci riteniamo pertanto responsabili per danni di qualsiasi natura o per altre implicazioni derivanti dall'esclusiva interpretazione delle informazioni fornite in merito a prodotti e applicazioni. Alcuni prodotti o servizi qui indicati potrebbero essere temporaneamente non disponibili. È proibita la riproduzione di tabelle, fotografie e dati, anche parziali, e con qualsiasi sistema, elettronico e non. Ci riserviamo il diritto di aggiornare e modificare in qualsiasi momento e senza preavviso metodi di produzione, ingredienti e caratteristiche dei materiali descritti nel catalogo.

We make no representation or warranties regarding the completeness or accuracy of the information, although recommendations and information on this catalogue, are believed to be accurate and correct and presented in good faith. The content of this catalogue is supplied upon the condition that the reader will make his own evaluation and determination to verify the suitability of the products for his purpose before using it. We won't be responsible for damages of any nature whatsoever resulting from the use of or reliance upon information included in this catalogue or the products to which the information refers. Products and services here indicated may be unavailable. Any reproduction of tables, pictures and data, even limited, by any system, even electronic, is forbidden. We reserve the right to update and modify production methods, ingredients and characteristics of the materials described in all pages at any time, without giving prior notice.



Indice

Index



Gamma prodotti	4	Products range	4
Sezione tecnica	8	Technical overview	8
Sistemi di tenuta per oleodinamica	54	Hydraulic sealing systems	54
- guarnizioni stelo		- rod seals	
- guarnizioni pistone		- piston seals	
- anelli guida		- wear rings	
- raschiatori		- wipers	
Tenute statiche	218	Static seals	218
- guarnizioni statiche		- static seals	
- guarnizione valvole a cartuccia		- cartridge valve seals	
O-Rings	236	O-Rings	236
- o-ring antirolling®		- o-ring antirolling®	
- anelli antiestrusione		- back-up rings	
Sistemi di tenuta per pneumatica	266	Pneumatic sealing systems	266
- guarnizioni stelo		- rod seals	
- guarnizioni ammortizzo		- cushion seals	
- guarnizioni pistone		- piston seals	
- anelli guida		- wear rings	
- raschiatori		- wipers	
- membrane scarico rapido		- quick exhaust valves membranes	
Poliuretano colato	328	Cast polyurethane	328

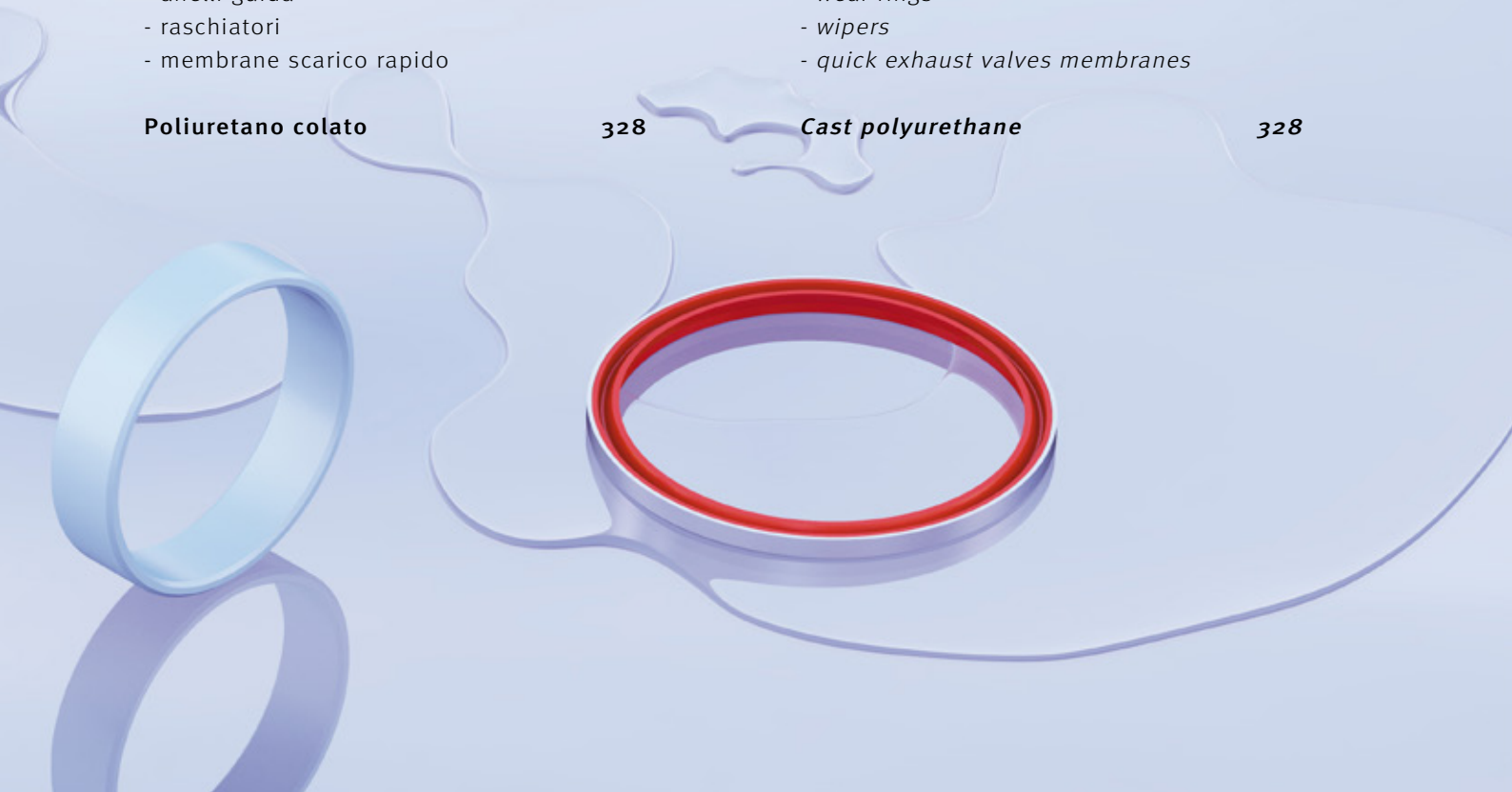

Gamma prodotti / Product range

GUARNIZIONI STELO / ROD SEALS										
Condizioni massime non simultanee / Maximum conditions (not combined)										
Profilo Profile	Ns Rif. Our Ref.	Temperatura Temperature C°	Pressione Pressure Bar	Velocità Speed m/s	Materiale Material	TPU POM / PA PTFE Bronze NBR	TPE Resina PTFE Carbo.	PTFE	Sezione Section	Pagina Page
	RSA	-35 +100	< 400	< 05	TPU	●			Idraulica Hydraulic	66
	RLF®	-35 +100	< 400	< 0,5	TPU	●			Idraulica Hydraulic	70
	RSB	-35 +100	< 400	< 05	TPU	●			Idraulica Hydraulic	74
	RSB2	-35 +100	< 500	< 0,5	TPU POM	● ○			Idraulica Hydraulic	80
	BLF®	-35 +100	< 400	< 05	TPU	●			Idraulica Hydraulic	82
	RSC	-35 +100	< 400	< 0,5	TPU	●			Idraulica Hydraulic	86
	RSD	-35 +100	< 400	< 0,5	TPU	●			Idraulica Hydraulic	90
	RPO	-35 +100	< 400	< 0,5	TPU	●			Idraulica Hydraulic	94
	AS®	-50 +135	< 400	< 0,5	TPU Technopolymer	●			Idraulica Hydraulic	98
	RSBI/RPOI	-35 +100	< 400	< 05	TPU	● ●			Idraulica Hydraulic	100
	RAA	-40 +115	< 600	< 1	POM	○			Idraulica Hydraulic	104
	TSS/P	-25 +100	< 600	5	TPU NBR	● ●	○		Idraulica Hydraulic	106
	TSS	-30 +120	< 600	15	PTFE bronzo/ bronze NBR	● ●			Idraulica Hydraulic	110
	RSO	-35 +100	< 400	< 0,5	TPU NBR	● ●			Idraulica Hydraulic	112
	RBR	-35 +100	< 400	< 0,8	TPU TPE	●	●		Idraulica Hydraulic	114
	RSS	-35 +100	< 400	< 0,5	TPU NBR	● ●			Idraulica Hydraulic	116
	RPS	-35 +100	< 400	< 0,5	TPU	●			Idraulica Hydraulic	118
	RSP	-40 +90	< 20	< 1	TPU	●			Pneumatica Pneumatic	274
	SRS	-40 +90	< 20	< 1	TPU	●			Pneumatica Pneumatic	276
	SRS/N	-30 +100	< 12	< 1	NBR		●		Pneumatica Pneumatic	278
GUARNIZIONI AMMORTIZZO / CUSHION SEALS										
	CSA	-40 +90	< 20	< 1	TPU	●			Pneumatica Pneumatic	280
GUARNIZIONI IN POLIURETANO COLATO / CAST POLYURETHANE SEALS										
	MAD-UMAD	-35 +100	< 400	-	TPU	●			Colata Cast	332
	CSC	-35 +100	< 400	-	TPU	●			Colata Cast	336
	RAD	-35 +100	< 500	-	TPU	●			Colata Cast	339



GUARNIZIONI PISTONE / PISTON SEALS										
Condizioni massime non simultanee / Maximum conditions (not combined)										
Profilo Profile	Ns Rif. Our Ref.	Temperatura Temperature C°	Pressione Pressure Bar	Velocità Speed m/s	Materiale Material	TPU POM / PA PTFE Bronze NBR	TPE Resina PTFE Carbo. PTFE	Sezione Section	Pagina Page	
	PSA	-35 +100	< 400	< 0,5	TPU	●		Idraulica Hydraulic	122	
	PAE	-35 +100	< 500	< 0,5	TPU POM	● ○		Idraulica Hydraulic	126	
	PSH+RR	-35 +100	< 400	< 0,5	TPU POM	● ○		Idraulica Hydraulic	128	
	PSO	-30 +100	< 250 materiali standard standard materials < 400 materiali alternativi alternative materials	< 0,5	TPU NBR	● ●		Idraulica Hydraulic	130	
	PSQ	-30 +100	< 250 materiali standard standard materials < 400 materiali alternativi alternative materials	< 0,5	TPU NBR	● ●		Idraulica Hydraulic	134	
	PSN	-30 +120	< 250	< 4	Technopolymer NBR		○	Idraulica / Pneumatic	136/302	
	TPD	-30 +120	< 600	15	PTFE bronzo/bronze NBR		● ●	Idraulica Hydraulic	138	
	PSI	-30 +100	< 300	< 0,5	TPU NBR	● ●		Idraulica Hydraulic	140	
	PSZ	-30 +110	< 600	1	PA66 NBR	● ●		Idraulica Hydraulic	142	
	PHP	-30 +100	< 600	< 1,5	TPU POM NBR	● ○ ●		Idraulica Hydraulic	144	
	KDSA	-30 +100	< 400	< 0,5	POM NBR TPE	○ ● ●		Idraulica Hydraulic	146	
	KDSB	-30 +100	< 400	< 0,5	POM NBR TPE	○ ● ●		Idraulica Hydraulic	148	
	KDSB/AE	-30 +100	< 400	< 0,5	POM NBR TPE	○ ● ●		Idraulica Hydraulic	152	
	KDSP	-35 +100	< 400	< 0,5	TPU POM	● ○		Idraulica Hydraulic	154	
	KDAE	-35 +100	< 400	< 0,5	TPU TPE	● ●	●	Idraulica Hydraulic	156	
	PSP	-40 +90	< 20	< 1	TPU	●		Pneumatica Pneumatic	282	
	MPS	-40 +90	< 20	< 1	TPU	●		Pneumatica Pneumatic	286	
	MPS/2	-40 +90	20	< 1	TPU	●		Pneumatica Pneumatic	288	
	MPM	-40 +90	< 20	< 1	POM NBR TPU	● ○ ●		Pneumatica Pneumatic	290	
	SPS	-40 +90	< 20	< 1	TPU	●		Pneumatica Pneumatic	292	
	SPS/N	-30 +100	< 12	< 1	NBR		●	Pneumatica Pneumatic	294	
	PLF	-40 +90	< 20	< 1	TPU	●		Pneumatica Pneumatic	296	
	MPP	-30 +100	< 20	< 1	NBR STEEL		●	Pneumatica Pneumatic	298	
	MPC	-35 +125	< 20	< 1	NBR STEEL		●	Pneumatica Pneumatic	300	



Gamma prodotti
Product range



RASCHIATORI / WIPERS									
Condizioni massime non simultanee / Maximum conditions (not combined)									
Profilo Profile	Ns Rif. Our Ref.	Temperatura Temperature C°	Pressione Pressure Bar	Velocità Speed m/s	Materiale Material	TPU POM / PA PTFE Bronzo NBR	TPE Resina PTFE Carbo. PTFE	Sezione Section	Pagina Page
	WSL	-35 +100	-	< 1	TPU	●		Idraulica Hydraulic	178
	RO6	-30 +100	-	< 4	NBR		●	Idraulica Hydraulic	182
	WSG	-35 +100	-	< 1	TPU STEEL	●		Idraulica Hydraulic	186
	IWP	-35 +100	-	< 0,8	TPU STEEL	●		Idraulica Hydraulic	188
	DWP	-35 +100	-	< 0,8	TPU STEEL	●		Idraulica Hydraulic	190
	R09	-30 +100	-	< 1	NBR STEEL		●	Idraulica Hydraulic	192
	WWS	-35 +100	-	< 1	TPU	●		Idraulica Hydraulic	194
	WWN	-35 +100	-	< 1	TPU	●		Idraulica Hydraulic	196
	RO8	-30 +100	-	< 4	NBR		●	Idraulica Hydraulic	198
	WAT	-35 +100	-	< 1	TPU	●		Idraulica Hydraulic	202
	TRD	-30 +120	-	< 15	PTFE bronzo/ bronze NBR		● ●	Idraulica Hydraulic	204
	WED	-35 +100	< 20	< 1	TPU	●		Idraulica Hydraulic	206
	WDA	-35 +100	< 50	< 1	TPU	●		Idraulica Hydraulic	210
	WIP	-40 +90	< 20	< 1	TPU	●		Idraulica Hydraulic	212
	WNM	-35 +100	< 20	< 1	PA Filled	●		Idraulica Hydraulic	214
	WEL	-35 +100	-	< 1	TPU	●		Idraulica Hydraulic	216
	LWA	-40 +90	-	< 1	TPU	●		Pneumatica Pneumatic	312
	BWA	-40 +90	< 20	< 1	TPU	●		Pneumatica Pneumatic	314
	PIW	-40 +90	< 20	< 1	TPU	●		Pneumatica Pneumatic	316
	BWS	-40 +90	< 20	< 1	TPU	●		Pneumatica Pneumatic	318
	BWH	-40 +90	< 20	< 1	TPU	●		Pneumatica Pneumatic	322
	BWH/N	-30 +100	< 20	< 1	NBR STEEL		●	Pneumatica Pneumatic	324

GUARNIZIONI ROTAZIONE / ROTARY SEALS									
	GDR	-35 +100	< 400	< 0,5	TPU	●		Idraulica Hydraulic	176



Gamma prodotti
Product range

ANELLI DI GUIDA / WEAR RINGS

(sezione tecnica guide pag. 158/ wear rings technical section pag. 158)

Condizioni massime non simultanee / Maximum conditions (not combined)

Profilo Profile	Ns Rif. Our Ref.	Temperatura Temperature C°	Pressione Pressure Bar	Velocità Speed m/s	Materiale Material	TPU POM / PA PTFE Bronze	NBR	TPE Resina PTFE Carbo. PTFE	Sezione Section	Pagina Page
	HIS HES	-40 +115	-	< 0,8	POM fibre di vetro glass fibres	○			Idraulica Hydraulic	162/166
	NG	-40 +200	-	15	PTFE bronzo/ bronze	●			Idraulica Hydraulic	170
	HPW	-50 +150	-	< 1	Resina Fenolica			●	Idraulica Hydraulic	172
	HEN	-40 +115	-	< 0,8	POM fibre di vetro glass fibres	○			Idraulica Hydraulic	174
	ISA	-40 +115	-	< 1	POM modificato/ <i>mo- dified</i>	○			Pneumatica Pneumatic	304
	ESA	-40 +115	-	< 1	POM modificato/ <i>mo- dified</i>	○			Pneumatica Pneumatic	306
	NG	-40 +200	-	15	PTFE carbografite			●	Pneumatica Pneumatic	310

GUARNIZIONI STATICHE / STATIC SEALS

	SSA	-35 +100	< 400	-	TPU	●			Statica Static	222
	VSS	-35 +100	< 400	-	TPU	●			Statica Static	228
	FSA	-35 +100	< 500	-	TPU	●			Statica Static	232
	VRA	-40 +90	-	-	TPU	●			Statica Static	234

O-RING / O-RING

	OR	vedi specifiche mescole o-ring see specifications of o-ring compounds							Statica Static	240
	OR IN TPU	vedi specifiche mescole o-ring see specifications of o-ring compounds							Statica Static	242
	OR ANTIROLLING®	vedi specifiche mescole o-ring see specifications of o-ring compounds							Statica Static	248

ANELLI ANTIESTRUSIONE / BACK-UP RINGS

	RAE/MAE	-30 +120	-	< 0,8	TPE			●	Statica Static	250/264
	AKN	-30 +100	-	< 0,8	NBR			●	Statica Static	250
	AKC	-40 +200	-	< 0,8	PTFE			○	Statica Static	250
	AKW	-40 +200	-	< 0,8	PTFE			○	Statica Static	250
	AKS	-40 +200	-	< 0,8	PTFE			○	Statica Static	250

MEMBRANE SCARICO RAPIDO / QUICK EXHAUST VALVES MEMBRANES

	CUP	-40 +90	<10	-	TPU	●			Pneumatica Pneumatic	326
--	------------	------------	-----	---	-----	---	--	--	-------------------------	-----

Sezione tecnica

Technical overview

Oleodinamica e pneumatica

Discipline consolidate della fluidodinamica, l'oleodinamica e la pneumatica sono orientate allo studio della trasmissione dell'energia tramite fluidi in pressione. La risoluzione di un problema in tali ambiti comporta generalmente lo sviluppo di complesse equazioni per definire proprietà del fluido come velocità, pressione, densità e temperatura in funzione di spazio e tempo. Grazie ai numerosi vantaggi e alla capacità di combinare formidabili concentrazioni di potenza con eccellenti capacità di controllo e regolazione, l'oleodinamica e la pneumatica risultano vincenti in moltissime applicazioni.

Nella tipica applicazione oleodinamica, la portata di olio generata da una pompa all'interno di un circuito oleodinamico è utilizzata per muovere un martinetto o un motore idraulico a seconda che l'effetto meccanico desiderato (forza o movimento) sia lineare o rotatorio. I cilindri oleodinamici sono attuatori lineari che convertono l'energia idraulica in meccanica generando forza e lo spostamento

Hydraulics and pneumatics

Hydraulics and pneumatics are very well-established branches of fluid dynamics, focusing on the study of energy transmission through fluids under pressure. Solving a problem in such fields usually implies the development of complex formulas, aiming at specifying the different fluid properties, such as for instance speed, pressure, density and temperature, as a function of space and time. Thanks to their countless advantages, those technologies are applied very successfully in a large number of mechanical engineering applications, as they combine outstanding concentrations of power with excellent control and adjustment capabilities.

In a typical hydraulic application, the oil flow generated by a pump in a hydraulic circuit is used to move a jack or a hydraulic motor to obtain the desired mechanical effect (force or movement), i.e. linear or rotational movement. Hydraulic cylinders are linear actuators converting hydraulic into mechanical energy, that generate a force and determine the linear displacement of the

Fig.1: tipi di cilindri
cylinders type

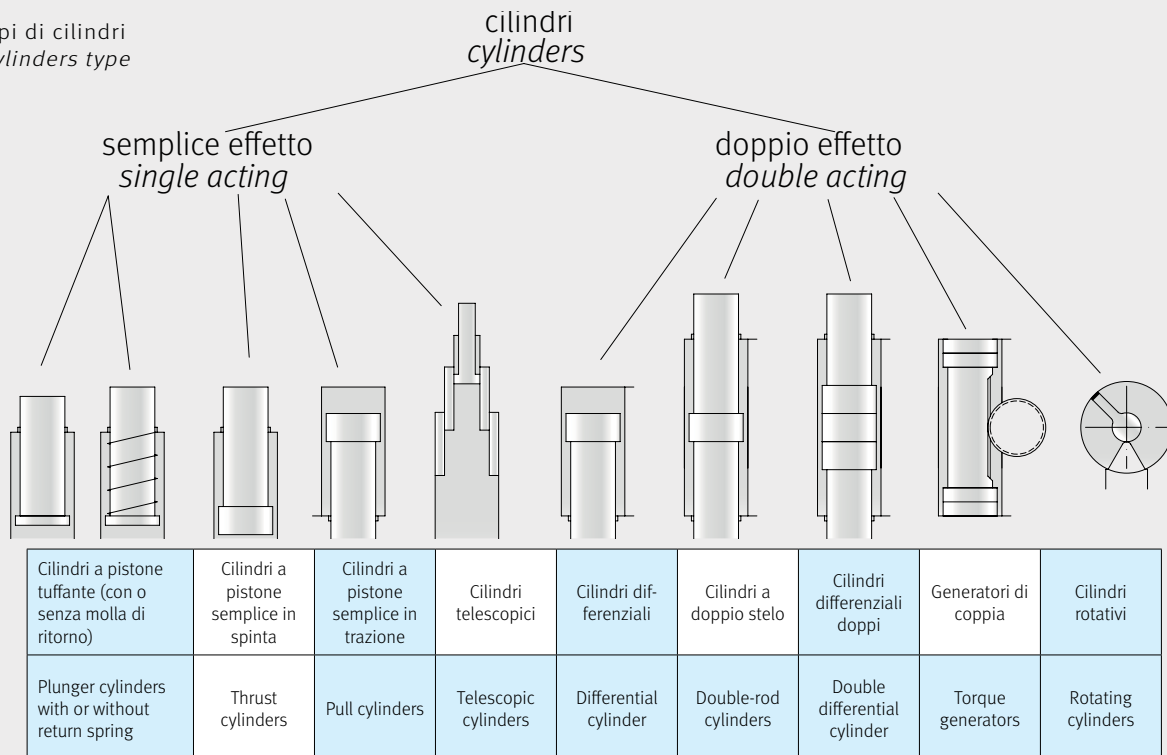



lineare del carico. In base alla funzione svolta sono a semplice o doppio effetto, secondo lo schema riportato.

All'interno di tali cilindri si fa largo impiego di guarnizioni, anelli realizzati in materiali elastomeri o termoplastici di sezione variabile che garantiscono la tenuta dei fluidi tra parti mobili e fisse in un ampio contesto di casistiche e applicazioni. Negli ultimi anni l'imporsi di condizioni di esercizio sempre più gravose e l'impiego di fluidi tecnologicamente evoluti hanno portato alla nascita di guarnizioni sempre più performanti. I nuovi polimeri in particolare, combinati a profili innovativi, riescono a garantire i risultati desiderati.

In tali contesti, le guarnizioni devono resistere principalmente alle pressioni, alle temperature e alle velocità di esercizio e risultare compatibili al contatto con determinati fluidi. Inoltre, per garantire il buon funzionamento nel tempo, devono avere una buona resistenza all'usura. Le guarnizioni devono quindi possedere elasticità, resistenza alla compressione e all'usura, durezza e compatibilità chimica con il fluido.

In sintesi, i fattori che influenzano l'intero sistema di tenuta in un cilindro sono molteplici e vanno considerati fin dalla progettazione delle guarnizioni che devono essere realizzate in stretta collaborazione con il produttore scegliendo i materiali più idonei e progettando i profili più adeguati. Solo così si otterranno sistemi di tenuta efficaci e affidabili nel tempo.

load. Depending on the function to be carried out, hydraulic cylinders can be grouped into two main categories: single-acting cylinders and double-acting cylinders, as shown in the diagram below.

Cylinders use a large number of seals, i.e. rings in elastomeric or thermoplastic materials with variable section, that shall guarantee the flawless sealing of fluids among the cylinder reciprocally movable and fixed parts, in a wide range of situations, mainly determined by the different application requirements.

In recent years, the introduction of new fluid types, as well as the fluid steadily increasing pressure and temperature levels, led to the development of new seal types, able to guarantee adequate performance standards. In particular, new polymers have been developed, that combined with innovative profiles enable to achieve the expected results.

Seals shall primarily withstand operating pressures, temperatures and speeds and offer compatibility with given fluids. Moreover they shall feature good wear resistance properties, in order to ensure efficient operating over time. Therefore, they shall offer elasticity, compressive strength, wear resistance, hardness and chemical compatibility with fluids.

As a result, the factors influencing the entire sealing system in a cylinder are many and shall all be taken into serious consideration right from the seal design phase, choosing the most suitable materials and designing the most effective profiles. The co-operation between the seals producer and the end user becomes then essential to develop efficient and reliable sealing systems in time.

Condizioni di esercizio

Operating conditions

Pressione

Nelle condizioni di esercizio la pressione gioca un ruolo fondamentale. Pressioni troppo elevate combinate con giochi di accoppiamento eccessivi tra stelo/testata e camicia/pistone rappresentano, nel medio termine, il primo motivo di deterioramento della guarnizione causato dall'estrusione con conseguenti perdite di fluido. Pressioni variabili, improvvise e di valore altissimo, provocate da fattori esterni e situazioni anomale, possono invece sottoporre le guarnizioni a forti shock e provocare lacerazioni e crepe capaci di compromettere l'intero sistema idraulico.

Anche l'assenza di pressione, o la prossimità allo zero, influisce negativamente su tutto il sistema. In questo caso è altrettanto complesso garantire la tenuta perfetta, affidata principalmente al modulo elastico del materiale della guarnizione e al suo profilo, disegnato affinché il precarico iniziale di montaggio risulti efficace alla tenuta anche in assenza di pressione, laddove manchi il supporto pressorio per mantenere i labbri della guarnizione contro la superficie di contatto. In questi casi si richiede l'impiego di tenute specifiche.

L'ampia scelta di profili Artic Seals, abbinati a materiali come poliuretani, gomme e polimeri in PTFE, consentono di individuare la soluzione ideale in tutte le applicazioni.

Temperatura

La temperatura del fluido da trattenerne influisce profondamente su vita ed efficienza della tenuta. Alla temperatura propria del fluido è necessario sommare una sovratemperatura provocata dall'attrito tra lo spigolo di tenuta della guarnizione e la superficie di contatto.

Pressure

Too high pressure values combined with excessive fitting clearance values between rod/head and liner/piston are the main cause of seals deterioration due to extrusion in the medium run, resulting in fluid leakages. Besides the typical operating pressure generated by the hydraulic system, other pressures may occur in cylinders: variable, unexpected and extremely high.

This happens when a machine supplied with hydraulic cylinders experiences anomalies and heavy-load events due to external factors. The resulting pressure peaks adversely affect the entire system, exposing the seals to heavy shock loads, that may cause tears or cracks and damage the whole hydraulic system.

Another condition negatively affecting the entire system is the lack of pressure or a pressure close to zero.

Also in that case, it is very complicated to ensure a flawless sealing, that will be basically left to the modulus of elasticity of the seal material and to its profile, conceived to ensure an effective initial mounting preload for the seal even in lack of pressure, where no pressure support is available to keep the seal lips against the contact surface. In those cases it would be appropriate to use specific seals.

The proposed product range offers a wide choice of profiles, which combined with different material typologies such as polyurethanes, rubbers and polymers of PTFE, enable to identify the ideal solution for any application.

Temperature

The temperature of the fluid to be retained has a major influence on the life and, therefore, the efficiency of the seal. Moreover an over temperature, that results from the friction between the seal lip and the contact surface, shall be added to the fluid own temperature.



L'entità della sovratemperatura dipende principalmente da:

- rugosità di stelo e camicia
- velocità
- pressione d'esercizio
- tipo di fluido da ritenere
- lubrificazione
- forma del labbro di tenuta
- anelli di guida.

La resistenza di una guarnizione alla somma delle temperature coinvolte è garantita dal materiale di realizzo. E per ogni tipologia di materiale esistono temperature tipiche di esercizio che possono variare notevolmente in funzione del profilo della guarnizione.

Quando ci si avvicina alle temperature limite individuate per ogni tipologia di guarnizione, possono comparire problemi sia alle basse sia alle alte temperature, poiché in entrambe le situazioni la viscosità del fluido e l'elasticità del materiale variano vistosamente. Alle alte temperature, per esempio, l'eccessiva viscosità può compromettere il potere lubrificante del fluido, basilare per mantenere il microfilm di olio che si crea tra il labbro di tenuta e la superficie di scorrimento. Il film lubrificante è in funzione della pressione idrodinamica generata dalla velocità del sistema e, in sua assenza, l'attrito derivato innalza rapidamente la temperatura della guarnizione. Il rischio è di assistere a una variazione di stato dell'elemento di tenuta, in base alla composizione del materiale, alla forma e alla durezza. Alle basse temperature invece la guarnizione si irrigidisce, con notevole perdita di elasticità, fino a giungere a un vero e proprio cambiamento di stato quando si tocca la temperatura di cristallizzazione del materiale di realizzazione, detta appunto transizione vetrosa.

Artic Seals propone una gamma di profili e materiali adatti ad applicazioni con un range di temperature molto ampio e compreso tra -50°C e $+220^{\circ}\text{C}$. Le temperature indicate nelle schede tecniche dei materiali sono puramente indicative in quanto testate su provini e in ambiente controllato.

The over temperature values depend on different factors, the main ones being:

- *rod and bore roughness*
- *speed*
- *operating pressure*
- *fluid to be retained*
- *lubrication*
- *sealing lip shape*
- *wear rings.*

Considering all temperatures involved, the main item that determines the seal resistance is the material it is made of. For each material type, typical operating temperatures are taken into consideration, that can vary considerably depending on the seal profile.

When getting closer to the limit temperatures of a given seal type, problems may arise both at high and low temperature, as significant changes in the fluid viscosity and material elasticity occur in both conditions.

At high temperatures, for example, the excessive fluid viscosity may damage its lubrication efficiency, which is essential to maintain the oil microfilm that forms between the sealing lip and the sliding surface.

The lubricant film is a function of the hydrodynamic pressure generated by the system speed and in lack of it, the resulting friction causes the seal temperature to raise in short time.

The risk is then to experience a change in the sealing item state, depending on the material, shape and hardness.

At low temperatures, the seal may stiffen losing a considerable share of its elasticity properties, up to a real change of state when it reaches the material crystallization temperature, specifically known as glass transition.

Artic Seal proposes a wide assortment of profiles and materials, suitable for applications with temperature between -50°C and $+220^{\circ}\text{C}$. Please note that the temperatures listed in the material technical data sheets are to be regarded as guideline values, as they are tested on specimens in a controlled environment.

Velocità

Parlando di velocità nelle condizioni di esercizio ci sono alcune variabili da considerare: la rugosità delle superfici di contatto, la temperatura dell'olio e la pressione d'esercizio. Queste tre variabili, insieme al tipo di materiale della guarnizione, possono determinare il valore massimo della velocità sostenibile dal sistema. Velocità comprese tra 0,03 e 0,3 m/s normalmente non compromettono il funzionamento del sistema di tenuta. In presenza di velocità molto basse, invece, la modesta pressione idrodinamica non riesce a mantenere costante lo spessore del meato d'olio che si crea tra i labbri della guarnizione e la superficie di scorrimento. Esso tende a rompersi e ricrearsi in continuazione e l'attrito che ne deriva genera un movimento a scatti (stick slip) con conseguente usura della guarnizione. Al contrario, a velocità troppo elevate la pressione idrodinamica tende a staccare il labbro di tenuta dalla superficie di contatto. In questa zona aumenta la temperatura e diminuisce la viscosità del fluido con la conseguente perdita.

Fluidi

In un cilindro idraulico si utilizzano normalmente oli a base minerale o ecologici biodegradabili. Le caratteristiche di ciascun tipo di fluido sono abitualmente vagliate da produttore e utilizzatore finale in base a esigenze specifiche (v. tabella 1).

Un aspetto molto importante da valutare è la compatibilità del fluido, olio in particolare, con le guarnizioni di tenuta. In caso di lubrificanti nuovi, poco utilizzati o mai testati, Artic Seals si rende disponibile a verificarne la compatibilità con le proprie guarnizioni presso la sala prove aziendale.

Speed

When it deals with speeds, some other variables shall be taken into consideration, i.e. the contact surface roughness, the oil temperature and the operating pressure.

These three variables together with the seal material may determine the system maximum admissible speed. Speeds in the range between 0,03 and 0,3 m/s, normally, do not affect the sealing system efficiency. In case of very low speeds, however, the poor hydrodynamic pressure is unable to maintain constant the thickness of the oil gap that forms between sealing lips and sliding surface. It tends to break and reform continuously and the resulting friction causes a "jerky" motion (stick-slip), leading to the seal wearing. On the contrary, at too high speeds the hydrodynamic pressure tends to "pull" the sealing lip away from the contact surface. In this area the temperature increases, while the fluid viscosity decreases, resulting in leakages.

Fluids

Hydraulic cylinders normally use mineral-base oils or biodegradable, environmentally friendly ones. The features of each fluid type are usually weighed by the manufacturer and the end users, depending on the specific needs. (See Table 1)

Hydraulic cylinders normally use mineral-base oils or biodegradable, environmentally friendly ones. The features of each fluid type are usually weighed by the manufacturer and the end users, depending on the specific needs. Below are listed the hydraulic oils on the market:



Condizioni di esercizio

Operating conditions



ARTIC SEALS

Tab. 1 - principali olii idraulici presenti sul mercato - *Principal Hydraulic oils on the market*

Liquidi a base di olio minerale/ <i>Mineral-oil based fluids</i>	Liquidi resistenti alla fiamma/ <i>Fire resistant fluids</i>	Liquidi ecologici / <i>Environmentally friendly fluids</i>	Liquidi speciali / <i>Special fluids</i>
HL Con additivi Anticorrosione e anti-vecchiamento / <i>With anticorrosion and anti-aging additives</i>	Acqua pura / <i>Pure water</i>	HETG Trigliceridi a base di oli vegetali (Olio di colza) / <i>Vegetable-oil-based tryglicerides (rapeseed oil)</i>	Liquidi sintetici per usi aeronautici / <i>Synthetic fluids for aeronautical use</i> MIL-H-5606A
HLP Come HL più additivi antigrippaggio / <i>Like HL plus anti-seize additives</i>	HFA Emulsione olio in acqua / <i>Oil-in-water emulsion</i> (80-98 % O)	HEPG Glicoli polietilenici e polialchilenici / <i>Polyethylene and polyalkylene glycols</i>	Liquidi sintetici per usi marini / <i>Synthetic fluids for marine use</i> NATO-H-540
HV Come HLP più additivi riduzione viscosità con la temperatura / <i>Like HLP plus additives reducing viscosity with temperature</i>	HFB Emulsione acqua in olio / <i>Oil-in-water emulsion</i> (40-50 % O)	HEE Esteri sintetici / <i>Synthetic esters</i>	
HLP-D Come HLP più additivi detergenti / <i>Like HLP plus detergent additives</i>	HFC Poliglicole in soluzione acquosa / <i>Polyglycole in water solution</i> (35..55 % O)		
	HFDR Esteri forforici / <i>Phosphate esters</i>		
	HFDS Idrocarburi clorati / <i>Chlorinated hydrocarbons</i>		
	HFDT Miscele di HFDR+HFDS / <i>HFDR+HFDS compounds</i>		

Tab. 2 - principali olii idraulici presenti sul mercato - *Principal Hydraulic oils on the market*

ISO classification	Sub Category	Composition	Wear Content	Typical Temperature Range (ISO)	Comments
HFA	HFAE	oil in water emulsion	>80%	+5 to +50 °C	Storage temperature >0°
	HFAS	Synthetic aqueous fluids	>80%	+5 to +50 °C	
HFB	-	Water-in-oil (invert emulsion)	> 40%	+5 to +50 °C	Storage temperature >0°
HFC	-	Water glicole solutions	> 35%	-20 to +50 °C	-
HFD	HFDR	Phosphate esters	None	-20 to +70°C	In some case, used up to 150°C but a such temperatures, the fluids may be subject at deterioration and shall be frequently checked (upper temperature limits for short-term only). In high-temperature circuits, i.e. above +100°C, special materials may have to be used for seals, packings, hoses etc. Where doubt exist, clarification should be sought from the equipment manufacturer and / or fluids.
	HFDU	Synthetic Anhydrous fluids other than phosphate esters (PAG / Polyol esters)	None	-20 to +70°C	

Compatibilità chimica

Chemical compatibility

Tab. 3 - Resistenza chimica dei materiali - *Chemical resistance of materials*

		poliuretano <i>polyurethane</i>	Resina acetica <i>Acetic resin</i>	Elastomero termoplastico <i>Thermoplastic elastomer</i>	Gomma nitrilica <i>Nitril rubber</i>	Gomma nitrilica idrogenato <i>Hydrogenated nitrile rubber</i>	Etilene propilene <i>Ethylene propylene</i>	Fluoroelastomero <i>Fluoroelastomer</i>	Fluorosilicone <i>Fluorosilicone</i>	Poli tetrafluoroetilene <i>Polytetrafluorethylene</i>
Fluido	<i>Fluid</i>	PU	POM	TPE	NBR	HNBR	EPDM	FKM	VMQ	PTFE
acetaldeide	<i>acetaldehyde</i>	●	●●●	●●	●	●	●●●	●	●	●●●
acetato di amile	<i>amyl acetate</i>	●	●	●	●	●	●●●	●	●	●●●
acetato di butile	<i>butyl acetate</i>	●	●●	●	●	●	●●	●	●	●●●
acetato di potassio	<i>potassium acetate</i>	●	●●●	●●	●	●	●●●	●	●	●●●
acetato di etilene	<i>ethyl acetate</i>	●	●●●	●●	●	●	●●●	●	●	●●●
aceto	<i>vinegar</i>	●	●●●	●●●	●●	●●	●●●	●●	●●●	●●●
acetone	<i>acetone</i>	●	●●●	●●●	●	●	●●●	●	●	●●●
acetoneitrile	<i>acetonitrile</i>	●	-	●●	●	●	●●	●	●	●●●
acetofenone	<i>acetophenone</i>	●	-	-	●	●	●●●	●	●	●●●
acetilene	<i>acetylene</i>	●	●●●	●●●	●	●	●●●	●	●	●●●
acido acetico (20%)	<i>acetic acid (20%)</i>	●	●●	●●●	●●	●●	●●●	●●	●●	●●●
acido acetico (5%)	<i>acetic acid (5%)</i>	●	●●●	●●●	●●	●●	●●●	●●	●●●	●●●
acido acetico (50%)	<i>acetic acid (50%)</i>	●	●	●●	●	●	●●●	●	●	●●●
acido carbossilico	<i>carboxylic acid</i>	●	-	-	●●●	●●●	-	-	-	●●●
acido citrico	<i>citric acid</i>	●	●●	●●	●●●	●●●	●●●	●●●	●●●	●●●
acido cloridrico (10%)	<i>chloric acid (10%)</i>	●	●	●●	●	●	●●	●●	●	●●●
acido cloroacetico (10%)	<i>chloroacetic acid (10%)</i>	●	●	●●	●	●	●●●	●	●	●●●
acido clorosolfonico	<i>chlorosulfonic acid</i>	●	●	●	●	●	●	●	●	●●●
acido cromico (10%)	<i>chromic acid (10%)</i>	●	●	●●	●	●	●●	●●●	●	●●●
acido cromico (25%)	<i>chromic acid (25%)</i>	●	●	●	●	●	●●	●●●	●	●●●
acido fenico	<i>carbolic acid</i>	●	-	-	●	●	●	●●	●	●●●
acido fluoridrico (10%)	<i>hydrofluoric acid (10%)</i>	●	●	●●	●	●	●●	●	●	●●●
acido formico	<i>formic acid</i>	●	●	●●	●	●	●●	●	●	●●●
acido fosforico (30%)	<i>phosphoric acid (30%)</i>	●	●	●●	●	●	●●●	●●●	●	●●●
acido gluconico	<i>gluconic acid</i>	●●	●●●	-	●	●	●●	-	-	●●●
acido muriatico	<i>muriatic acid</i>	●	●	●●	●	●	●●	●●●	●	●●●
acido nitrico (10%)	<i>nitric acid (10%)</i>	●	●	●●	●	●	●	●●●	●	●●●
acido nitrico concentrato	<i>nitric acid concentrated</i>	●	●	●	●	●	●	●●●	●	●●●
acido oleico	<i>oleic acid</i>	●	●●●	●●	●●●	●●●	●	●●●	●	●●●
acido palmitico	<i>palmitic acid</i>	●●	●●●	●●●	●●	●●	●	●●●	●	●●●
acido perclorico (10%)	<i>perchloric acid (10%)</i>	●	●	●●●	●	●	●●	●●●	●	●●●
acido solforico (30%)	<i>sulphuric acid (30%)</i>	●	●	●●●	●	●	●●●	●●●	●	●●●
acido tartarico	<i>tartaric acid</i>	●	●	●●	●●●	●●●	●●	●●●	●●●	●●●
acido tricloroacetico	<i>trichloroacetic acid</i>	●	●	●●●	●●	●●	●●	●	●●	●●●
alcol metilico	<i>methyl alcohol</i>	●	●●●	●●	●●●	●●●	●●●	●	●●●	●●●
acqua	<i>water</i>	●●	●●●	●●	●●●	●●●	●●●	●●●	●●●	●●●
acqua 100°C	<i>water 100°C</i>	●	●●●	●●	●●	●●●	●●●	●●	●●	●●●
acqua ammoniacale	<i>ammonia water</i>	●	●	-	●	●	●●●	●●	-	●●●
acqua clorurata >0,5 ppm	<i>chlorine ater >0.5 ppm</i>	●	●●	●●●	●	●	●●	●●●	●	●●●
acqua distillata	<i>distilled water</i>	●●	●●●	●●●	●●	●●●	●●	●●	●●●	●●●
acqua glicole	<i>glycol water</i>	●●	●●●	●●	●●●	●●●	●●●	●●●	●●●	●●●
acqua marina	<i>sea water</i>	●●●	●●●	●●●	●●●	●●●	●●●	●●●	●●	●●●
acqua olio	<i>oil water</i>	●●	●●●	●●●	●●●	●●●	●	●●●	●●●	●●●
acqua ossigenata (1%)	<i>hydrogen peroxine (1%)</i>	●	●●●	●●●	●●	●●	●●	●●●	●●●	●●●
acqua ossigenata (30%)	<i>hydrogen peroxine (30%)</i>	●	●	●●●	●	●	●	●●●	●●	●●●
alcol etilico	<i>ethanol</i>	●	●●	●●●	●●●	●●●	●	●●●	●●	●●●
alcol metilico	<i>methanol</i>	●	●●●	●●●	●●●	●●●	●●●	●●●	●●	●●●
ammia di butile	<i>butyl amine</i>	●	●	●	●	●	●	●	●	●●●
ammoniaca (10%)	<i>ammonia (10%)</i>	●	●	-	●●●	●●●	●●●	●	●	●●●
anidride acetica	<i>acetic dioxide</i>	●	●	●	●●	●●	●●	●	-	●●●
anidride carbonica	<i>carbon dioxide (wet and dry)</i>	●	●●●	●●●	●●●	●●●	●●	●●●	●●	●●●



Compatibilità chimica
Chemical compatibility



ARTIC SEALS™

Attenzione: consultare il nostro ufficio tecnico per le altre compatibilità

Attention :consult our technical department for the other compatibility

Tab. 3 - Resistenza chimica dei materiali - Chemical resistance of materials

		poliuretano polyurethane	Resina acetica Acetalic resin	Elastomero termoplastico Thermoplastic elastomer	Gomma nitrilica Nitril rubber	Gomma nitrilica idrogenato Hydrogenated nitrile rubber	Etilene propilene Ethylene propylene	Fluoroelastomero Fluoroelastomer	Fluorosilicone Fluorosilicone	Poli tetrafluoroetilene Polytetrafluorethylene
Fluidi	Fluid	PU	POM	TPE	NBR	HNBR	EPDM	FKM	VMQ	PTFE
anidride solforosa	sulphur dioxide	●	●	●●●	●	●	●●●	●●	●●	●●●
anilina	aniline	●	●●	●	●	●	●●●	●	●	●●●
argon	argon	●●●	-	●●●	●	●	●●●	●●●	-	●●●
aria	air	●●●	●●●	●●●	●●●	●●●	●●●	●●●	●●●	●●●
azoto	nitrogen	●●●	●●	●●●	●●	●●●	●●●	●●●	●●●	●●●
benzaldeide	benzaldehyde	●	●●●	●●	●	●	●●●	●●●	●●●	●●●
benzina	benzine (gasoline)	●●●	●●●	●●●	●●	●	●	●●●	●	●●●
benzina 100 ottani	benzine 100 octane	●●	●●●	●●●	●●●	●●●	●	●●●	-	●●●
benzina minerale	benzine mineral	●●	●●●	-	●●●	●●●	●	●●●	-	●●●
benzolo	benzol	●	●●●	●●	●	●	●	●●	●	●●●
birra	beer	●	-	●●●	●●●	●●●	●●●	●●●	●●●	●●●
borace	borax	●●●	●●●	●●●	●●	●●	●●●	●●●	●●●	●●●
bromuro	bromide	●	●	●	●	●	●	●●●	-	●●●
butadiene	butadiene	●	●●●	●	●	●	●	●●●	●	●●●
butano	butane	●●●	●●●	●●●	●●●	●●●	●	●●●	●	●●●
butanolo	butanol	●	●●●	●●	●●●	●●●	●●	●●●	-	●●●
butilene	butylene	●	●●●	●●	●●	●●	●	●●●	-	●●●
caffè	coffee	●	●●●	●●	●●●	●●●	●●●	●●●	●●●	●●●
candeggiante (10%)	bleach solution (10%)	●	●	●●	●	●	●●●	●●●	●	●●●
carburante diesel	diesel fuel	●●	●●●	●●●	●●●	●●●	●	●●●	●	●●●
cherosene	kerosene	●●	●●●	●●●	●●●	●●●	●	●●●	●	●●●
ciclo esano	cyclo hexane	●●●	●●●	●●●	●●●	●●●	●	●●●	●	●●●
cloro	chlorine	●	●	●	●	●	●	●●●	-	●●●
clorobenzene	chlorobenzene	●	●	●	●	●	●	●●●	-	●●●
cloropropene	chloropropene	●	-	-	●	●	●	●●	-	●●●
cloroformio	chloroform	●	●●	●●	●	●	●	●●	●	●●●
cloruro di acetile	acetyl chloride	●	●	●	●	●	●	●●●	-	●●●
cloruro di bario	barium chloride	●●●	●●●	●●	●●●	●●●	●●●	●●●	-	●●●
cloruro di calcio (10%)	zinc chloride	●●●	●	●●●	●●●	●●●	●●●	●●●	-	●●●
cloruro di etilene	ethylene chloride	●	●●●	●	●	●	●	●●	-	●●●
cloruro di potassio	potassium chloride	●●●	●●●	●●	●●●	●●●	●●●	●●●	-	●●●
cloruro di sodio (10%)	sodium chloride (10%)	●	●●	●●●	●●●	●●●	●●●	●●●	●●●	●●●
cloruro di zinco	zinc chloride	●	●●	●●●	●●●	●●●	●●●	●●●	●●●	●●●
cloruro ferrico	ferric chloride	●●●	●●	●●●	●●●	●●●	●●●	●●●	-	●●●
combustibile per aerei (JP1-JP5)	aircraft fuel (JP1-JP5)	●●	●●●	-	●●●	●●●	●	●●●	-	●●●
combustibile per aerei (JP6)	aircraft fuel (JP6)	●	●●●	-	●●●	●●●	●	●●●	-	●●●
detergente	detergent	●	●●●	●●	●●●	●●●	●●●	●●●	-	●●●
dicloruro di etilene	ethylene dichloride	●	●●●	●	●	●	●	●●	-	●●●
diesel	diesel	●	●●●	●●	●●●	●●●	●●●	●●●	-	●●●
diemtilformamide	dimethylformamide	●	●	●●	●●	●●	●●	●●	-	●●●
diossido di carbonio	carbon dioxide	●●●	●●●	●	●●●	●●●	●●	●●●	-	●●●
diossolventi di cellulosa	cellulose solvent	●	●●●	●	●	●	●●	●	-	●●●
diossolventi Stoddard	Stoddard solvent	●●●	●●●	●	●●●	●●●	●	●●●	-	●●●
elio	helium	●●●	●●●	●●●	●●●	●●●	●●●	●●●	-	●●●
eptano	heptane	●●●	●●●	●●●	●●●	●●●	●	●●●	●	●●●
esano	hexane	●●●	●●●	●●●	●●●	●●●	●	●●●	●	●●●
etanolo	ethanol	●	●●●	-	●	●	●	●	●	●●●
etere di butile	buthyl ether	●●	●	●	●●	●●	●	●	-	●●●

Valori indicativi/indicative values

●●●=buono/ good

●●=sufficiente/ fair

●=insufficiente/ poor

Condizioni di prova: a temperatura ambiente - testata su provette

Operating conditions: room temperature - tested on specimens

Compatibilità chimica

Chemical compatibility

Tab. 3 - Resistenza chimica dei materiali - *Chemical resistance of materials*

		poliuretano <i>polyurethane</i>	Resina acetilica <i>Acetalic resin</i>	Elastomero termoplastico <i>Thermoplastic elastomer</i>	Gomma nitrilica <i>Nitril rubber</i>	Gomma nitrilica idrogenato <i>Hydrogenated nitrile rubber</i>	Etilene propilene <i>Ethylene propylene</i>	Fluoroelastomero <i>Fluoroelastomer</i>	Fluorosilicone <i>Fluorosilicone</i>	Poli tetrafluoroetilene <i>Polytetrafluorethylene</i>
Fluido	<i>Fluid</i>	PU	POM	TPE	NBR	HNBR	EPDM	FKM	VMQ	PTFE
etere etilico	<i>ether</i>	●	●●●	-	●	●	●●	●	●	●●●
etere di petrolio	<i>petroleum ether</i>	●●	●●●	-	●●●	●●●	●	●●●	-	●●●
etilendiammina	<i>ethylenediamine</i>	●	●●●	-	●●●	●●●	●●●	●	-	●●●
etilene glicolico	<i>ethylene glycolic</i>	●●	●●	●●●	●●●	●●●	●●●	●●●	-	●●●
fenolo	<i>phenol</i>	●	●●●	●	●	●	●	●●●	-	●●●
fluido per freni	<i>brake fluid</i>	●	●●●	●	●	●	●●●	●	-	●●●
formaldeide (37%)	<i>formaldehyde (37%)</i>	●	●●●	●●	●	●	●●●	●	●	●●●
freon 11	<i>freon 11</i>	●	●●●	●●	●●	●●	●	●●	●	●●●
freon 12	<i>freon 12</i>	●●	●●●	●●●	●●	●●	●●	●●●	●	●●●
freon 21	<i>freon 21</i>	●●	●●●	●●●	●	●	●	●	●	●●●
freon 22	<i>freon 22</i>	●	●●●	●●	●	●	●●●	●	●	●●●
freon 113	<i>freon 113</i>	●●●	●●●	●●●	●●	●●●	●	●●	●	●●●
freon 114	<i>freon 114</i>	●●●	●●●	●●●	●●●	●●●	●●●	●●	●	●●●
furfurolo	<i>furfural</i>	●	●●	●●	●	●	●●	●	-	●●●
gas naturale	<i>natural gas</i>	●●	●●●	●●●	●●●	●●●	●	●●●	●	●●●
gas di petrolio liquefatto (GPL)	<i>liquefied petroleum gas (LPG)</i>	●●●	●●	●●	●●●	●●●	●	●●●	-	●●●
gas propano	<i>propane gas</i>	●●●	●●●	●●●	●●●	●●●	●	●●●	●	●●●
gasolio	<i>diesel oil</i>	●●●	●●●	●●●	●●●	●●●	●	●●●	●	●●●
glicerina	<i>glycerine</i>	●	●●●	●●	●●●	●●●	●●●	●●●	●●●	●●●
glicole	<i>ethylene glycol</i>	●	●●●	●●●	●●●	●●●	●●●	●●●	●●●	●●●
glucosio	<i>glucose solution</i>	●	●●●	-	●●●	●●●	●●●	●●●	●●●	●●●
grasso minerale	<i>mineral grease</i>	●●●	●●●	●●●	●●●	●●●	●	●●●	●●	●●●
idrogeno gas	<i>hydrogen gas</i>	●●●	●●●	●●●	●●●	●●●	●●●	●●●	●	●●●
idrogeno solforato	<i>hydrogen sulphide</i>	●●	●●●	●●●	●	●	●●●	●	-	●●●
idrossido di ammonio	<i>ammonium hydroxide</i>	●	●●	●●	●●	●	●●●	●●	-	●●●
idrossido di bario	<i>barium hydroxide</i>	●●	●	●●	●●	●●●	●●●	●●●	-	●●●
idrossido di magnesio	<i>magnesium hydroxide</i>	●	●●●	●●	●●	●●	●●●	●●●	-	●●●
idrossido di potassio (50%)	<i>potassium hydroxide (50%)</i>	●●	●●●	●●●	●	●	●●	●	-	●●●
idrossido di sodio (soda caustica)	<i>sodium hydroxide</i>	●●	●●●	●	●	●	●●●	●●	-	●●●
ipoclorito di sodio (5%)	<i>sodium hypochlorite (5%)</i>	●	●	●●●	●●	●●	●●●	●●●	●●	●●●
isobutene	<i>isobutene</i>	●	-	-	●	●	●	●●●	-	●●●
kerosene	<i>kerosene</i>	●●	●●●	●●●	●●●	●●●	●	●●●	-	●●●
lubrificanti mototri SAE	<i>engine lubricant SAE</i>	●●	●●●	●●●	●●●	●●●	●	●●●	-	●●●
latte	<i>milk</i>	●	●●●	-	●●●	●●●	●●●	●●●	●●●	●●●
mercurio	<i>mercury</i>	●●●	●●●	●●●	●●●	●●●	●●●	●●●	●●●	●●●
metano	<i>methane</i>	●●●	●●●	●●●	●●●	●●●	●	●●●	●●●	●●●
metiletilchetone	<i>methyl ethyl ketone</i>	●	●●	●●●	●	●	●●	●●	●	●●●
nafta	<i>naphta</i>	●	●●●	●●●	●	●	●	●●●	-	●●●
nafta da petrolio	<i>petroleum naphta</i>	●●	●●	●●●	●●●	●●●	●	●●●	-	●●●
nitrate potassico	<i>potassium nitrate</i>	●●●	●●	-	●●●	●●●	●●●	●●●	-	●●●
nitrobenzene	<i>nitrobenzene</i>	●	●●	●	●	●	●	●●	-	●●●
nitrometano	<i>nitromethane</i>	●	●●●	●	●	●	●●	●	-	●●●
nitropropano	<i>nitropropane</i>	●	-	-	●	●	●●	●	-	●●●
oli vegetali	<i>vegetal oils</i>	●●●	●●●	●●●	●●●	●●●	●	●●●	●	●●●
olio al silicone	<i>silicone oil</i>	●●●	●●●	●●●	●●●	●●●	●●	●●●	●	●●●
olio ASTM 1	<i>oil ASTM 1</i>	●●●	●●●	●●●	●●●	●●●	●	●●●	●●●	●●●
olio ASTM 3	<i>oil ASTM 3</i>	●●●	●●●	●●●	●●●	●●●	●	●●●	●●	●●●
olio combustibile	<i>fuel oil</i>	●●●	●●●	●●●	●●	●●	●	●●●	●	●●●
olio d'oliva	<i>olive oil</i>	●●●	●●●	●●●	●●●	●●●	●●	●●●	-	●●●
olio di palma	<i>palm oil</i>	●●	●●●	-	●●●	●●●	-	●●●	-	●●●
olio di petrolio <121°C	<i>petroleum oil <121°C</i>	●●	●●	-	●●●	●●●	●	●●	-	●●●



Compatibilità chimica
Chemical compatibility



ARTIC SEALS™

Attenzione: consultare il nostro ufficio tecnico per le altre compatibilità

Attention :consult our technical department for the other compatibility

Tab. 3 - Resistenza chimica dei materiali - Chemical resistance of materials

		poliuretano polyurethane	Resina acetica Acetatic resin	Elastomero termoplastico Thermoplastic elastomer	Gomma nitrilica Nitril rubber	Gomma nitrilica idrogenato Hydrogenated nitrile rubber	Etilene propilene Ethylene propylene	Fluoroelastomero Fluoroelastomer	Fluorosilicone Fluorosilicone	Poli tetrafluoroetilene Polytetrafluoroethylene
Fluido	Fluid	PU	POM	TPE	NBR	HNBR	EPDM	FKM	VMQ	PTFE
olio di petrolio >121°C	petroleum oil >121°C	●	●●	-	●●●	●●●	●	●●	-	●●●
olio di pino	pine oil	-	●●●	●	●●	●●	●	●●●	-	●●●
olio idraulico	hydraulic oil	●●●	●●	●●●	●●	●●	●	●●●	-	●●●
olio lubrificante	lubricating oil	●●●	●●●	●●●	●●●	●●●	●	●●●	●●	●●●
olio minerale	mineral oil	●●●	●●●	●●●	●●●	●●●	●	●●●	●●	●●●
olio paraffinico	paraffin oil	●●●	●●●	●●●	●●●	●●●	●	●●●	●	●●●
olio per motore	engine oil	●●	●●●	●●●	-	-	●	●●●	-	●●●
olio per freni	break oil	●	●●	●●	-	-	●●●	●●●	-	●●●
olio ATF II	ATF II oil	●●●	●●●	●●●	●●	●●	●	●●●	●	●●●
olio ATF III	ATF III oil	●●	●●	●●	●	●	●	●●●	●	●●●
olio ATF IV	ATF IV oil	●	●	●●	●	●●	●	●●●	●	●●●
oli SAE	SAE oil	●●●	●●●	●●●	●●●	●●●	●	●●●	-	●●●
ossido etilenico	ethylene oxide	●	●●●	●●●	●	●	●	●	-	●●●
ossigeno	oxygen	●●	●●●	●●●	●	●	●●●	●●●	●●●	●●●
ottano	octane	●	-	-	●●●	●●●	●	●●●	-	●●●
ottanolo	octanol	●	-	-	●●	●●	●●●	●●●	-	●●●
ozono	ozone	●●	●●●	●●●	●	●	●●●	●●●	●●●	●●●
paraffina	paraffin	-	●●●	●●●	●●●	●●●	●	●●●	●●	●●●
pentano	pentane	●	●●●	-	●●●	●●●	●	●●●	-	●●●
pentanolo (alcol amilico)	penatnol (amyl alcohol)	●	-	-	●●	●●	●●●	●●	-	●●●
percloro etilene	perchlore ethylene	●	●●	●●●	●	●	●	●●●	●●●	●●●
propano	propane	●●	●●●	●●	●●●	●●●	●	●●●	-	●●●
propanolo	propanol	●	-	-	●	●	●●●	●	-	●●●
propilene	propylene	●	●●●	-	●	●	●	●●●	-	●●●
piridina	pyridina	●	●●	●	●	●	●●	●●	-	●●●
saccarosio	sucrose	●	-	-	●●●	●●●	●●●	●●●	-	●●●
sale idrofugo	salt water repellent	●	●●●	●●●	●●●	●●	●●	-	-	●●●
soda	sodium	●●	●●●	●●	●	●	●●●	●●	-	●●●
succo di frutta	fruit juices	●	●●●	-	●●	●●	●●●	●●	●●●	●●●
solfo di alluminio	aluminium sulfate	●	●●●	●●	●●	●●	●●●	●●●	-	●●●
solfo di calcio	calcium sulfate	●●●	●	-	●●●	●●●	●●●	●●●	-	●●●
solfo di potassio	potassium sulfate	●●●	-	-	●●●	●●●	●●●	●●●	●●●	●●●
trementina/acquaragia	turpentine	●	●●●	-	●●●	●●●	●	●●●	●	●●●
tetracloroetilene	tetrachlorethylene	●	●●●	-	●	●	●	●●●	-	●●●
tetracloruro di carbonio	carbon tetrachloride	●	●●●	●	●	●	●	●●●	-	●●●
tetraidrofurano	tetrahydrofuran	●	●	●●	●	●	●●	●	-	●●●
toluene	toluene	●	●	●	●	●	●	●●●	-	●●●
tricloretilene	trichloethylene	●	●●	●	●	●	●	●●●	-	●●●
urea (5%)	urea (5%)	●	●●●	-	●●●	●●●	●●●	●●●	●●●	●●●
vapore	vapour	●	●●●	-	●	●	●●	●●●	●●	●●●
vaselina	vaseline	●●	●●●	●●●	●●●	●●●	●●	●●●	●	●●●
vetro solubile	soluble glass	●	●●●	●●●	●●●	●●●	●●●	●●●	-	●●●
vino	wine	●	●●	●●	●●●	●●●	●●●	●●●	●●●	●●●
xeno	xenon	●●●	-	-	●●●	●●●	●●●	●●●	-	●●●
xilene	xylene	●	●●●	●●	●	●	●	●●●	-	●●●

Valori indicativi/indicative values

●●●=buono/ good

●●=sufficiente/ fair

●=insufficiente/ poor

Condizioni di prova: a temperatura ambiente - testata su provette

Operating conditions: room temperature - tested on specimens

Classificazione e denominazione dei materiali Artic Seals

Classification and designation of Artic Seals materials

Materiali

Nel determinare la guarnizione ideale per una specifica applicazione, la scelta del materiale è l'aspetto più importante e complesso poiché bisogna orientarsi tra una moltitudine di polimeri.

Il materiale va selezionato anche sulla base dei vincoli previsti da ogni sistema di tenuta.

Tra i più significativi vi sono:

- compatibilità chimica tra la tenuta e il fluido o l'ambiente lavorativo
- attrito/usura: indispensabile per determinare la vita e le prestazioni della tenuta
- proprietà meccaniche: definiscono la resistenza del materiale alle sollecitazioni meccaniche
- resistenza all'estrusione: definisce i limiti meccanici del materiale
- assemblaggio, stoccaggio e movimentazione, indispensabili per preservare le caratteristiche delle tenute.

Di seguito i polimeri più utilizzati in ambito guarnizioni.

Materials

To determine the most suitable seal for a specific application, the material choice is for certain one of the most important issues and perhaps the most complex one, due to the variety of polymers currently available on the market. Moreover, the material shall be accurately selected based on the binding requirements specified for the sealing systems. Among them, the most important are the following ones:

- *chemical compatibility: contact seal material and the fluid used and/or the operating environment*
- *friction/Wear: It is essential to evaluate the seal life and performances*
- *extrusion resistance: It is essential to evaluate the material suitability*
- *information assembling: storing and handling methods. Essential to maintain the seal performance.*

Checking the sealing system main features, that may impact on the seal material, makes the material selection much easier and effective. Find below a brief overview of the polymers most commonly used for seal manufacturing.



Classificazione e denominazione dei materiali Artic Seals

Classification and designation of Artic Seals materials

Tab. 4 - THERMOPLASTIC ELASTOMERS - POLIURETHANES : TPU

Artic Seals Code	Description	Colour identification	Typical Applications & Description	Service Temperature Range °C (F°)	Shore Hardness	
					A	D
AO	Polyether copolymer-based TPU	Light Violet	Combines hardness with excellent mechanical properties and good hydrolysis resistance. Ideal for Pneumatic applications like rod seals, piston seals and wipers	-40 to +90	85	
AT	Virgin Polyether copolymer-based TPU	Transparent	Combines low hardness with excellent mechanical properties and good hydrolysis resistance. Ideal for Pneumatic applications like rod seals, piston seals and wipers.	-40 to +90	85	
AG	Graphite Filled Polyether copolymer-based TPU	Graphite Grey	Combines hardness with excellent mechanical properties and good hydrolysis resistance. Improved wear resistance and reduced friction compared with standard Ao TPU.	-40 to +90	85	
Bo	polyether-based thermoplastic polyurethane	Light Grey	Exceptional performance in terms of compression set, wear resistance and hydrolysis resistance. Excellent Pneumatic rod seals, piston seals and wipers	-40 to +90	90	
BT	Virgin polyether-based thermoplastic polyurethane	Transparent	Exceptional performance in terms of compression set, wear resistance and hydrolysis resistance. Excellent for hydraulic and Pneumatic seals, at very low temperature.	-45 to +90	90	
BG	Graphite Filled polyether-based thermoplastic polyurethane	Graphite Grey	Exceptional performance in terms of compression set, wear resistance and hydrolysis resistance. Improved wear resistance and reduced friction compared with standard Bo. Excellent for Pneumatic rod seals, piston seals and wipers.	-40 to +90	90	
Co	Caprolactone-based thermoplastic polyurethane.	Violet	Exceptional performance in terms of compression set, wear resistance and hydrolysis resistance over conventional polyester-based TPUs. Material produced by Kasting.	-35 to +110	94	
CT	Caprolactone-based thermoplastic polyurethane.	Transparent	Exceptional performance in terms of compression set, wear resistance and hydrolysis resistance over conventional polyester-based TPUs. Material produced by Kasting. Transparent version	-35 to +110	94	
Do	Polyester based thermoplastic polyurethane.	Fuchsia	Grease and oil-resistant; low compression set; good heat resistance, high elasticity, good for automotive engineering, technical parts and bearing bushes	-35 to +110	98	
Eo	Polyether based polyurethane	natural white	High antiextrusion resistance for antiextrusion ring, wipers and special applications. Better resistance to hydrolysis and microbiological attack, a very good cold flexibility but a lower resistance to oxidation, in comparison with Polyester TPUs.	-25 to +100		62
Go	PPDI isocyanate based thermoplastic polyurethane	Dark Grey	Offers a combination of properties not obtainable with MDI polyurethane based. Very low compression set at elevated temperatures (+135°C) , Resistance to abrasion, flex cracking, cutting and tearing, rebound resilience are all taken to a significantly higher level.	-30 to +135	93	
GT	Virgin PPDI isocyanate based thermoplastic polyurethane	Transparent	Offers a combination of properties not obtainable with MDI polyurethane based. Very low compression set at elevated temperatures (+135°C) , Resistance to abrasion, flex cracking, cutting and tearing, rebound resilience are all taken to a significantly higher level.	-30 to +135	93	

Classificazione e denominazione dei materiali Artic Seals
Classification and designation of Artic Seals materials

Tab. 5 - THERMOPLASTIC ELASTOMERS: TPE

Artic Seals Code	Description	Colour identification	Typical Applications & Description	Service Temperature Range °C (F°)	Shore Hardness	
					A	D
L0	High performance thermoplastic polyester elastomer	Black	Dedicated to anti-extrusion rings and special parts requiring food contact compatibility. Food compliance specificity. It show extended resistance to extrusion and excellent fluid compatibility.	-55 to +110		37
L1	Thermoplastic polyester elastomer	Yellow	Mainly used for production of anti-extrusion rings. It show extended resistance to extrusion and excellent fluid compatibility.	-30 to + 130 (Peaks till -50 to +150)		55
L2	Thermoplastic polyester elastomer	Light violet	Mainly used for production of anti-extrusion rings. It show extended resistance to extrusion and excellent fluid compatibility.	-30 to + 130 (Peaks till -50 +150)		63
L7	Thermoplastic polyester elastomer	White	General purpose industrial parts, with extended resistance to extrusion and excellent fluid compatibility.	-30+ 130 (Peaks till -50 +150)		72
L9	Thermoplastic polyester elastomer	Natural	General purpose industrial parts, with extended resistance to extrusion and excellent fluid compatibility.	-55 to + 110		40

Tab. 6 - SYNTHETIC FLUOROPOLYMER: Polytetrafluoroethylene (PTFE)

Artic Seals Code	Description	Colour identification	Typical Applications & Description	Service Temperature Range °C (F°)	Shore Hardness	
					A	D
T1	PTFE Virgin	White	Wide temperature range, excellent sliding properties, good steam and hot water resistance; FDA approved.	-190 to +230		55 - 57
T3	PTFE fiber Glass Filled (15%), Graphite, MoS ₂ (3%)	Green	Developed for hydraulic piston seals, involved in extreme conditions such as high pressure, high temperature, wear resistance on hardened dynamic surfaces.	-190 +260		55 - 61
TM	PTFE Bronze Filled (40%)	Brown	High compressive load and extrusion resistance, ideal for hydraulic rod/piston seals.	-150 +260		58 - 65
TV	PTFE Bronze Filled (40%)	Green	High compressive load and extrusion resistance, ideal for hydraulic wearing.	-150 +260		58 - 65
TC	PTFE Graphite Filled (15%)	Black	High chemical and corrosive resistance, low abrasion for soft shaft. Self-lubricating properties, ideal for hydraulic wearing.	-190 +230		55
T4	PTFE Carbon Filled (10%)	Dark Grey	Good in water service, very high chemical resistance against strong alkali and hydrofluoric acid.	-190 +230		64 - 67

Tab. 7 - THERMOPLASTIC ENGINEERED RESIN: COMPOSITE RESIN

Artic Seals Code	Description	Colour identification	Typical Applications & Description	Service Temperature Range °C (F°)	Shore Hardness	
					A	D
S0	Phenol resin Cotton fabric reinforced	Tan	Self-lubrication, good mechanical properties, good dimensional stability and chemical resistance. Excellence in water resistance and in abrasion resistance. Excellence in impact. Main applications are wear ring for all kinds of cylinder, sliding bearing and bushes.	-60 to +150		80 (45)*
S1	Phenol resin polyester fabric reinforced with PTFE	Light blue	Self-lubrication, good mechanical properties, good dimensional stability and chemical resistance. Excellence in water resistance and in abrasion resistance. Excellence in impact. Main applications are wear ring for all kinds of cylinder, sliding bearing and bushes.	-60 +150		75 (45)*
S3	Phenol resin polyester fabric reinforced with GRAPHITE	Dark grey	Excellent dimensional stability and abrasion resistance. Self-lubrication and wide chemical resistance. Excellence in water. Main applications are wear ring for all kinds of cylinder, sliding bearing and bushes.	-50 +150		80 (45)*



Classificazione e denominazione dei materiali Artic Seals

Classification and designation of Artic Seals materials

Tab. 8 - THERMOPLASTIC ENGINEERED RESIN: POM- PA-PBT

Artic Seals Code	Description	Colour identification	Typical Applications & Description	Service Temperature Range °C (F°)	Shore Hardness	
					A	D
R0	POM homopolymer 20% glass fiber filled	Black	High stiffness, low warpage and low creep for superior performance at elevated temperature. It contains carbon black for improved weathering. Primary application is Hydraulic wearing.	-40°C to +115°C		85
R2	POM homopolymer Heat stabilized	White	Acetal homopolymer, with improved thermal stability, good mechanical properties, and low volatile emissions.	-40°C to +115°C		85
R2FG	POM homopolymer Food Grade	White	Food compliance specificity; Acetal homopolymer, with improved thermal stability. It has been developed for consideration into applications such as parts for the food industry.	-40°C to +115°C		85
R3	POM filled 10% PTFE/Silicone	White	Self-lubricating material, good wear resistance. Mainly used for pneumatic wearing. It shows high mechanical properties, low friction coefficient and low wear.	-40°C +115°C		84
R1	PA6 40% glass fiber filled	Black	The glass fiber reinforcement enhances performance such as strength, stiffness and heat deflection temperature. The heat stabilizer system extends the properties at elevated temperatures. It also has excellent chemical resistance to greases, oils and hydrocarbons	-40°C +140°C		86
R4	PA6 + MOS ₂	Dark Grey	Heat stabilized PA6 filled with MoS ₂ , ideal for hydraulic special items such as bushings, wipers and back-up rings where there is a demand for high toughness and low friction. Self lubricating compound.	-40°C +130°C		85
R6	PA66	White	Super tough polyamide 66 outstanding break resistance over a wide range of temperature and umidity range . Ideal for piston seal, bushing and back up ring.	-40°C +130°C		85
R7	PA66 30% glass fiber filled	Black	The glass fiber reinforcement enhances performance such as strength, stiffness and heat deflection temperature. The heat stabilizer system extends the properties at elevated temperatures. It also has excellent chemical resistance to greases, oils and hydrocarbons	-40°C +140°C		86
R9	PA6 40% glass fiber and 15% PTFE filled	Black	Heat stabilized PA6 40% glass fiber and 15% PTFE filled, ideal for hydraulic special items such as bushings, wipers and back-up rings where there is a demand for high toughness and low friction. . Self lubricating compound.	-40°C + 140°C		85 - 88
P2	Polibutilentereftalato (PBT)	White	PBT compound based filled with PTFE. It shows excellent self-lubricating properties. General purpose for industrial and meccanichal applications.	-30+ 130 (Peaks -50 +150)		72

Classificazione e denominazione dei materiali Artic Seals
Classification and designation of Artic Seals materials

Tab. 9 - THERMOSET ELASTOMERS : Nitrile (NBR)

Artic Seals Code	Description	Colour identification	Typical Applications & Description	Service Temperature Range °C (F°)	Shore Hardness	
					A	D
N0	NBR 70 Sh	Black	General purpose nitrile rubber, ideal for soft seals like standard Oring energizing element for PFTE sealing system	-30 +100	70	
N1	NBR 73 Sh	Black	General purpose nitrile rubber, ideal for soft seals like standard Qring and energizing element for PFTE sealing system	-30 +100	73	
N2	NBR 75 Sh	Black	General purpose nitrile rubber, with low compression set, good chemical compatibility and good modulus, ideal for pneumatic sealing system.	-30 +100	75	
N3	NBR 75 Sh	Black	General purpose nitrile rubber, with low compression set, good chemical compatibility and good modulus, ideal for pneumatic sealing system.	-35 +120	75	
N4	NBR 90 Sh	Black	Hard nitrile with high modulus and good compression set, for outstanding antiextrusion application.	-30 +100	90	
N5	NBR 80 Sh	Black	Premium nitrile, for use application where its required perfect sealing at low temperature.	-60 +100	80	

Tab. 10 - THERMOSET ELASTOMERS : Fluorocarbon Elastomer (FKM)

Artic Seals Code	Description	Colour identification	Typical Applications & Description	Service Temperature Range °C (F°)	Shore Hardness	
					A	D
FKM75	Fluoro-elastomer 75SH	Black / Brown	General purpose Fluorocarbon, strong resistance to chemical attack and heat	-25 + 200	75	
FKM 85	Fluoro-elastomer 85SH	Brown	General purpose Fluorocarbon, strong resistance to chemical attack and heat	-20 +200	85	

Tab.11- TPUs different based comparison

Parameter	Polyester based TPUs	Polycaprolactone based TPUs	Polyether based TPUs
Hydrolysis Resistance	-	+	++
Microbial stability	-	+	+
Adhesion strength	+	++	+
Thermooxidative resistance	+	+	+
Low temperature flexibility	0	+	++
Mechanical proprieties	+	++	+
Oil and grease resistance	+	++	+

(++ excellent; + good; 0 acceptable; - poor; -- very poor)

The above reported values are based on laboratory tests performed on specimen and reflected typical material properties. The application limits are maximum values determined in the laboratory. It is recommended that customers perform adequate testing to evaluate the suitability of each individual products.



PU – Poliuretano

Resina uretanica ampiamente utilizzata nel settore delle guarnizioni ottenuta tramite reazione tra poliolo, di-isocianato ed estensore di catena. Due le tipologie di poliuretani a seconda del tipo di poliolo di base: polietere e poliestere.

Differenti anche i tipi di di-isocianato. Tra i più utilizzati: MDI, PPDI e TODI. La combinazione tra tipologia di poliolo da un lato e di-isocianato dall'altro dà origine a prodotti eterogenei, le cui caratteristiche fisiche e meccaniche variano significativamente, così come le applicazioni di utilizzo.

TPE – Termoplastico elastomero

Il termoplastico elastomero è una resina poliestere disponibile in diversi gradi di durezza adatta ad applicazioni oleodinamiche, specialmente per anelli di supporto e anti-estrusione.

Materiale flessibile come gli elastomeri e dotato di proprietà meccaniche simili alle materie plastiche, ha ottima resistenza a taglio e abrasione ed elevate caratteristiche chimiche. È compatibile con oli lubrificanti, idrocarburi e molti fluidi come acidi e basi.

POM – Polimetilossido

Il polimetilossido, comunemente conosciuto come resina acetica, è utilizzato nella costruzione di boccole, anelli anti-estrusione e pattini di guida nei cilindri. Ha ottime proprietà di rigidità, elevata resistenza all'urto e alla fatica e un alto modulo elastico. Non essendo igroscopico ha ottima stabilità dimensionale e supporta, con o senza cariche aggiuntive, carichi radiali importanti.

Le molte versioni si differenziano tra loro per l'additivo introdotto e per la sua percentuale. Per esempio, il POM per le fasce di guida a contatto con superfici in acciaio è caricato con fibra di vetro, mentre si carica con PTFE per ridurre l'attrito.

PU – Polyurethane

Urethane resin increasingly used to manufacture seals. It is obtained by reaction among polyol, diisocyanate and a chain extender. In seals division, two main polyurethanes are used depending on the base polyol: polyether and polyester. Another important classification concerns the diisocyanate type, the most used being MDI, PPDI and TODI. The combination between polyol and diisocyanate typology results in very different products, whose physical and mechanical features vary significantly, as well as the applications they are intended for. The TPUs currently on the market are elastomers with high performing mechanical characteristics and featuring excellent tensile strength, as well as very good tearing, abrasion and cutting resistance; they are usually compatible with mineral oils, greases, hydrocarbons and petroleum derivatives. Standard TPUs normally feature a poor compatibility with hot water, acids, alkaline solutions, steam.

TPE – Thermoplastic elastomer

The thermoplastic elastomer is a polyester resin available in different hardness degrees. It is suitable for hydraulic applications, and ideal for support and backup rings. The material features the flexibility of elastomers and the mechanical properties of plastics. Excellent abrasion and cutting resistance. It has very good chemical properties, that make it compatible with lubricant oils and hydrocarbons, as well as with many fluids like acids and alkalis.

POM – Polymethyloxide

The polymethyloxide, commonly known as "acetal resin", is used to manufacture bushings, backup rings and guide shoes in cylinders. It features excellent properties in terms of stiffness, high shock resistance and fatigue strength, with high modulus of elasticity. It is not hygroscopic, therefore offers outstanding dimensional stability and can take heavy radial loads, with or without additional fillers. Depending on the additive type and content percentage, many different versions are available. One example is glass-fibre-filled POM, used to manufacture guide strips intended for contact with steel surfaces, or PTFE-filled POM to reduce friction,

Classificazione e denominazione dei materiali Artic Seals *Classification and designation of Artic Seals materials*

Utilizzato al naturale per accoppiamenti con metalli teneri come alluminio o ottone.

PA – Poliammide

Il poliammide, comunemente chiamato nylon, è un tecnopolimero. Presenta peso specifico relativamente basso, resistenza a urti e usura, discreto isolamento elettrico, resistenza a solventi, oli, grassi, carburanti e autoestinguenti. A differenza della resina acetica, il poliammide rimane più stabile alle temperature oltre i 140 °C. Utilizzato per pattini guida e boccole, dove la temperatura è costantemente elevata, è comunemente caricato con carbonio, PTFE, bisolfuro di molibdeno o con fibre di vetro e/o altri additivi per ottenere caratteristiche fisiche/ meccaniche più performanti.

PTFE – Politetrafluoroetilene

Il politetrafluoroetilene (PTFE) è il polimero del tetrafluoroetene. Ad alto peso molecolare, è un termoindurente senza punto di fusione e può essere lavorato tramite processo di sinterizzazione. Il PTFE presenta una serie di caratteristiche interessanti come:

- la completa inerzia chimica (non è aggredito dalla quasi totalità dei composti chimici)
- bassissimo coefficiente di attrito: a oggi il più basso tra i prodotti industriali
- la completa insolubilità in acqua e in qualsiasi solvente organico
- ottime qualità dielettriche
- ottima resistenza al fuoco: non propaga la fiamma.

Queste caratteristiche rimangono praticamente inalterate in un range di temperature comprese tra i -80 °C e i 260 °C con picchi anche superiori. Da qui l'ampio utilizzo in campo industriale, alimentare, elettrico e chimico. Nel settore idraulico-pneumatico è ampiamente utilizzato per la produzione di guarnizioni e fasce di guida. Avendo un basso modulo elastico è spesso proposto in tandem con particolari elastomerici ad alta memoria elastica o in metallo a forma di molla, per conferire elasticità/

to name a couple.

To manufacture parts in combination with soft metals, as aluminium or brass, the natural polymer should be the preferred choice.

PA – Polyamide

The polyamide commonly known as Nylon is a technopolymer. It features relatively low specific weight, shock and wear resistance, fairly good electric insulation, resistance to solvents, oils, greases and self-extinguishing fuels. Unlike acetal resin, this material is more stable at temperature over 140 °C. It is used for guide shoes and bushings, where temperature are constantly high. It is usually filled with carbon, PTFE, molybdenum disulfide, or glass fibre and/or other additives, to achieve improved physical/mechanical performing characteristics.

PTFE - Polytetrafluoroethylene

The polytetrafluoroethylene (PTFE) is the high-molecular-weight polymer of tetrafluoroethene. It is a thermosetting material with no melting point, that can be processed through sintering. The PTFE offers a number of interesting features, among which:

- *total chemical inertia, which makes it resistant to almost all chemicals;*
- *extremely low friction coefficient, currently the lowest among industrial products;*
- *complete insolubility in water and in any organic solvent*
- *excellent dielectric properties;*
- *outstanding fire resistance properties, i.e. no flame propagation.*

Those feature become even more important, as that they are maintained virtually unaltered in the temperature range between -80 °C and 260 °C, with even higher peaks.

It is used for a variety of applications in the industrial, food, electric and chemical fields. In the hydraulic-pneumatic segment it is used to produce seals and guide strips. Thanks to its low modulus of elasticity, it is often proposed in combination with high memory elastomeric parts or metal spring-



energia. In fase di montaggio è spesso necessaria la calandatura meccanica.

Proposto sia puro sia caricato con vari additivi e in varie percentuali con molibdeno, fibre di vetro, carbonio, grafite e bronzo, il PTFE è ricavabile sia con metodo isostatico, consigliato per alte pressioni, sia con metodo non isostatico fino a 400 bar.

Resina Fenolica

La resina fenolica è un materiale sintetico ottenuto dalla reazione chimica tra il fenolo e la formaldeide con cui si impregnano fibre di cotone o poliestere. Proposta sia al naturale sia additivata con PTFE, vetro e grafite, presenta elevata tenacità e resistenza a trazione e usura e un basso coefficiente di attrito. Buona la resistenza a oli minerali, grassi e a soluzioni non aggressive di acidi e alcali. È impiegata quasi esclusivamente per produrre anelli di guida ed è inadatta a impieghi alimentari per la sua composizione chimica.

NBR – Gomma Nitrilica

Elastomero a base di butadiene e di acrilonitrile in quantità variabile impiegato nella maggior parte delle applicazioni. Con ottimo ritorno elastico è impiegato principalmente nella produzione di guarnizioni e o-ring.

Particolarmente indicato a contatto con:

- oli a base paraffinica (alifatici)
- oli e grassi minerali (oli motore, per cambi, differenziali)
- oli idraulici
- acqua e soluzioni acquose (liscive).

Invecchia rapidamente se esposto a sole, aria o agenti atmosferici in generale. Estremamente versatile dal punto di vista applicativo grazie a compatibilità termica e stabilità delle caratteristiche meccaniche da -40°C a 120°C nelle sue varie formulazioni.

shaped ones, to add elasticity/energising properties. Mechanical keying is often required to accomplish the mounting procedure.

- *PTFE is available pure or filled with different additives in different percentages, as well as with molybdenum and glass, carbon, graphite and bronze fibres*
- *available proceeds with either isostatic method, which is recommended for high pressures, with that method does not isostatic up to 200 bar.*

Phenolic Resin

Phenolic resin is a synthetic material obtained by chemical reaction between the phenol and formaldehyde, used to impregnate cotton or polyester fibres.

It feature high toughness, low friction coefficient, high tensile strength and wear resistance .

It is used almost exclusively to manufacture guide rings.

PTFE and GRAPHITE are normally used as additives, both with cotton and polyester fibres.

Good resistance to mineral oils, greases and mild solutions of acids and alkalis.

Due to its chemical composition, it is not suitable for usage in the food industry.

NBR - Nitrile Rubber

This elastomer, based on butadiene and acrylonitrile in variable quantity, is used in the majority of applications.

It offers an excellent spring-back and is mostly used to manufacture O-rings.

It is ideal with:

- *paraffin-based oils (aliphatic)*
- *mineral oils and greases (engine oils, gearbox, differential oils, etc.)*
- *hydraulic oils*
- *water and water solutions (lyes).*

Exposure to air, sunlight or weathering in general accelerates the material aging.

Thanks to its thermal compatibility from -30°C to peaks of 120°C , it is extremely versatile in terms of applications, while maintaining its mechanical characteristics.

HNBR – Gomma Nitrilica Idrogenata

Elastomero ottenuto idrogenando un tipo di gomma nitrilica (NBR) che consente, specialmente se vulcanizzato a perossido, di ottenere una resistenza a temperature e abrasioni superiore a quella della gomma NBR standard. In particolare risulta indicato per:

- resistenza al calore
- resistenza all'ozono
- resistenza all'abrasione
- resistenza alle basse temperature.

La resistenza a oli e solventi risulta in media di poco superiore alla gomma nitrilica, salvo casi particolari. Ampio il campo di applicazione grazie al mantenimento di caratteristiche meccaniche dai -40°C a punte di 150 °C.

EPDM – Gomma etilene-propilene

È una gomma sintetica a base di etilene propilene più un terzo monomero (diene) che consente la reticolazione a zolfo. Grazie alla struttura chimica presenta una peculiare resistenza a fluidi come acqua, vapore e ambienti con alta percentuale di ozono. Per questo risulta particolarmente indicata per:

- acqua fino all'ebollizione
- vapore
- sistemi idraulici come impianti frenanti
- ozono
- agenti atmosferici
- basi
- solventi polari a temperatura ambiente
- range di temperature da -50°C a + 150°C.

FKM – Elastomero Fluorurato

Il fluoro elastomero, comunemente chiamato Viton®, è una gomma sintetica molto resistente al calore. Resiste ottimamente a oli, idrocarburi alifatici e aromatici e agli agenti chimici. Perfetto per la produzione di o-ring o di tenute dove è richiesta stabilità e memoria elastica alle alte temperature.

HNBR - Hydrogenated Nitrile Rubber

The chemical structure of this elastomer (resulting from the hydrogenation of a suitable type of NBR nitrile rubber) enables to increase the temperature and abrasion resistance compared to the standard NBR rubber, in particular if peroxide-vulcanized.

It is very suitable when the following requirements are requested:

- *heat resistance*
- *ozone resistance*
- *abrasion resistance.*

The resistance to oils and solvents is averagely slightly higher compared to nitrile rubber, with few exceptions.

It offers a very wide application range, while maintaining its mechanical features in the temperature range from -40°C to peaks of 150 °C.

EPDM- Rubber ethylene- Polypropylene

It deals with a synthetic rubber, based on ethylene-propylene and a third monomer (diene), which enables the sulphur crosslinking.

Thanks to its chemical structure, it features a excellent resistance to fluids such as water and steam, and is suitable for environments with high ozone percentage. For these reasons it is ideal for:

- *water up to boiling point*
- *steam*
- *special hydraulic systems such as braking systems*
- *ozone*
- *weathering*
- *alkalis*
- *polar solvents at room temperature*
- *temperature range between -50°C and + 150°C.*

FKM - Fluorocarbon Elastomer

The fluoro-elastomer, commonly known as Viton®, is a synthetic rubber with high thermal resistance.

It features excellent resistance to oils, aliphatic and aromatic hydrocarbons and chemicals.

Ideal to manufacture O-rings or seals for application requiring stability and memory at high temperature.



VMQ – Gomma Siliconica

Per la sua composizione chimica presenta una notevole resistenza ad agenti atmosferici, luce e ozono. Mostra inoltre un'eccellente resistenza a basse e alte temperature. La resistenza a lacerazione e abrasione non è completamente soddisfacente ma è ampiamente compensata dal suo basso coefficiente di attrito. Utilizzata in campo medicale, alimentare ed elettrico, è indicata per la resistenza a:

- agenti atmosferici
- a oli minerali, vegetali, naturali e idraulici (se la temperatura non supera i 60°C)
- a fluidi a base glicolica (non utilizzabile con le benzine)
- a temperature variabili tra – 55°C fino a punte di 180°C.

FMQ – Fluoro Silicone

Il fluorosilicone ha caratteristiche meccaniche simili alla gomma siliconica, ma la presenza del fluoro nella composizione ne aumenta di molto la compatibilità a idrocarburi alifatici e aromatici, agli acidi e agli oli animali e minerali per l'intero range di temperatura di lavoro. Al contrario della gomma siliconica, il fluoro diminuisce le prestazioni alle alte e basse temperature.

QMV - Silicone Rubber

Thanks to its chemical composition, it features high resistance to weathering, light and ozone. Moreover, the excellent properties of resistance to high and low temperatures enable a wide operating range. Although its tearing and abrasion resistance is not completely satisfactory, its low friction coefficient compensate for efficiency. It is used both in the medical and food industry. Ideal for applications with requirements for:

- *resistance to weathering*
- *resistance to mineral, vegetable and natural oils, and also hydraulic oils, if temperature does not exceed 60°C*
- *resistance to glycol-based fluids*
- *never use with petrols*
- *resistant to variable temperatures from – 55°C to peaks of 180°C.*

FMQ - Fluorine Silicone

The fluoro silicone features mechanical characteristics similar to the fluoro rubber, but the fluorine in the composition increases considerably the compatibility with animal oils in the entire operating temperature range, as well as with aliphatic and aromatic hydrocarbons and acids. Conversely, it decreases performances at high and low temperatures.

Note about the pigmentation of the polymers used by Artic Seals:
Possible variations in colour shades may result from the usage of master-batch free from heavy metals. Such slight variations do not affect the seals mechanical features

Proprietà fisiche e meccaniche degli elastomeri *Elastomers physical and mechanical properties*

Nella determinazione e configurazione di una tenuta, nonché nel garantire le sue performance nel tempo, bisogna analizzare attentamente le caratteristiche fisiche e meccaniche dei materiali.

Durezza

La durezza è la proprietà del materiale che misura la resistenza alla penetrazione. Nel campo degli elastomeri esistono due scale di misurazione: la durezza Shore (Shore A per durezza comprese tra 40 a 90 Sh e Shore D per valori da 90 Sh) e il Grado Internazionale di Durezza della Gomma (IRHD). Per la misurazione si usa un durometro con puntina a tronco-cono per la Shore A e con angolo a 30° per la Shore D.

In entrambi i casi la misurazione è regolamentata dalle norme DIN 53505 e ASTM D2240. Di seguito lo schema di sovrapposibilità delle due scale e il posizionamento dei principali polimeri.

To specify and design a seal, as well as to guarantee its performances over time, it is necessary to analyse the material essential physical/mechanical features.

Hardness

Typically, under hardness we understand the property, that specifies the material resistance to penetration.

The two main hardness measuring scales in the field of elastomers are the Shore hardness and the International Rubber Hardness Degrees (IRHD).

As for Shore hardness, two more reference scales are used, i.e. "Shore A" and "Shore D".

To measure the hardness degree, both scales use an hardness meter, but different indenters: the indenter for scale "Shore A" features a truncated cone point, while the one for scale "Shore D" has a 30°-angled point.

Durometer hardness test

Fig.2: test di durezza
Pic.2: hardness test

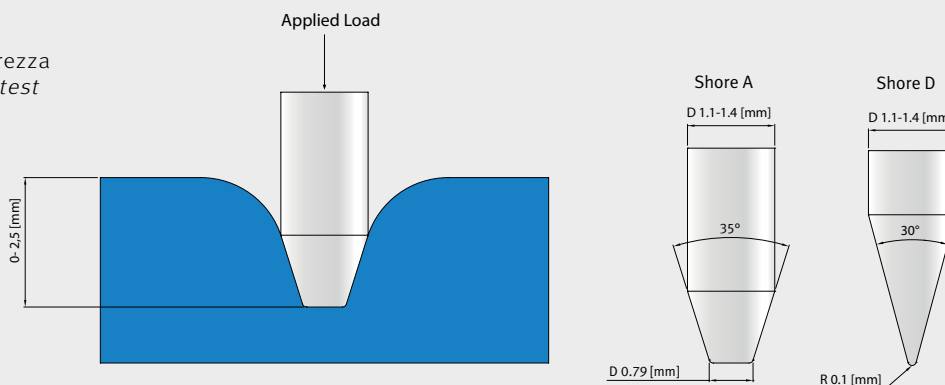
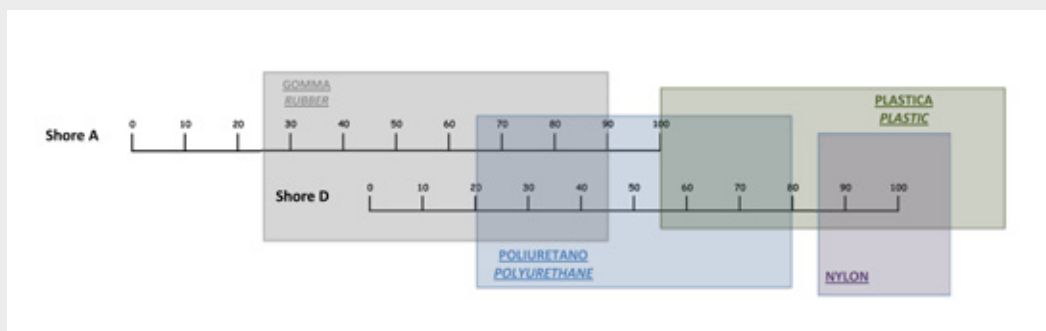

Fig.3: scala di durezza
Pic.3: hardness scale





La durezza è un parametro molto importante in ambito guarnizioni perché influenza sia l'attrito dinamico sia di primo distacco. A parità di spinta e rugosità della sede, una durezza bassa riduce l'attrito di primo distacco; al contrario, una durezza elevata riduce l'attrito dinamico. La durezza a sua volta è influenzata dalla temperatura e diminuisce con l'innalzarsi della temperatura. Generalmente gli elastomeri con durezza bassa, cioè più teneri, si adattano meglio alle superfici più ruvide ma sono più soggetti all'estrusione. La durezza è generalmente influenzata anche dai liquidi con cui la guarnizione rimane in contatto.

Scale Shore A is used for hardness values between 40 and 90 Sh, while for higher values the Shore D scale is the reference one.

In both cases, the measurements conform to standards DIN 53505 and ASTM D2240. Find below the reference scales overlapping pattern, as well as the position of the main polymers.

In the field of seals, hardness is a very important parameter, that needs to be taken into account, as it affects both dynamic friction and stiction.

Thrust and seat roughness being equal, a low hardness degree reduces stiction, while a high hardness degree reduces dynamic friction.

Hardness, in turn, is influenced by temperature, i.e. the higher the temperature and the lower the hardness. In general, elastomers with low hardness degree, i.e. softer, are better suited for rougher surfaces, but are more prone to extrusion.

Resistenza alla compressione, memoria elastica, compression set

La resistenza alla compressione è la capacità di un elastomero di ritornare al suo spessore originale dopo prolungate sollecitazioni di compressione e deformazione a una data temperatura. Un elastomero, compresso a lungo nel tempo, tende infatti a perdere la sua capacità di ritornare alla dimensione originale.

La differenza tra la dimensione originale e quella finale si esprime in percentuale e rappresenta il compression set del materiale analizzato. Più la percentuale di compression set è bassa, migliore è la resistenza alla compressione di un materiale.

Compressive strength, memory, compression set

It deals with the capacity of elastomers to recover their original thickness after experiencing prolonged compressive and deformation stresses at a given temperature. After a long time under compression, elastomers tend to lose the ability to recover their original thickness. The difference between the original and final dimensions is expressed in percentage and represents the compression set of the material being tested. The lower the compression set percentage and the better the material compressive strength.

As far as seals are concerned, their efficiency is strongly influenced by the seal material compression

Fig.4: test compression set

Pic.4: compression set test

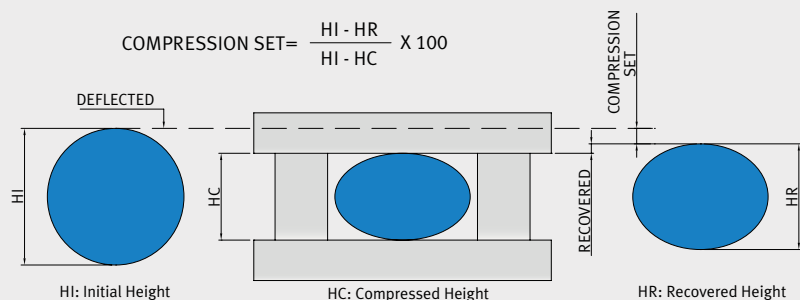

In ambito guarnizioni, la funzionalità di una tenuta è fortemente influenzata dal livello di compression set del materiale di realizzazione. Una scarsa resistenza alla compressione, ossia un alto compression set, può compromettere la funzionalità della guarnizione che non è più in grado di mantenere la tenuta per un lungo periodo di tempo.

Per contro, un'alta resistenza alla compressione, ossia un basso compression set, è indicativa di una buona durata nel tempo della tenuta statica e dinamica. Visto che la tenuta è sottoposta a pressione durante il ciclo, è fondamentale che la guarnizione riprenda la sua forma originale a fine ciclo per evitare la perdita di fluido.

Modulo di elasticità

Il modulo elastico misura la quantità di forza necessaria a mettere in tensione un provino di materiale e allungarlo fino a una percentuale predefinita della sua dimensione originaria.

Normalmente si valuta il modulo elastico al 50% (forza necessaria per allungare il provino del 50% della sua dimensione originaria), al 100% e al 300%. Più è alto il valore confermato dalla prova di trazione, migliori sono le caratteristiche del materiale. Nel campo delle tenute è preferibile un elevato modulo elastico in quanto garantisce:

Fig.5: test allungamento

Pic.5: elongation test

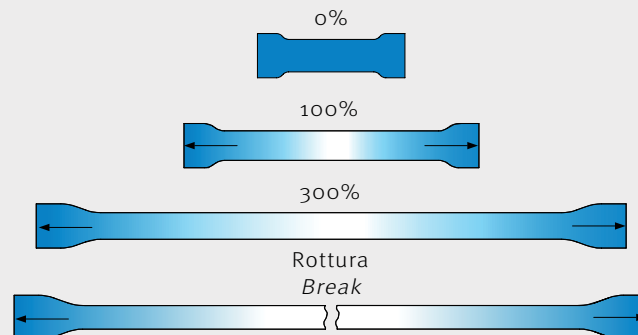

set. A low compressive strength, i.e. a high compression set value, can negatively influence the efficiency of the seal, that will no longer be able to guarantee the sealing function over a long period of time. Conversely, a high compressive strength, i.e. a low compression set value, suggests good dynamic and static sealing efficiency over time. As seals are subject to pressure during the working cycle, the ability to recover their original shape at the end of the cycle is of paramount importance, in order to prevent fluid leakages.

Elastic modulus

The modulus of elasticity measures the force necessary to tension a material specimen and extend it to a given percentage of its original size.

Normally the test evaluates the modulus of elasticity at 50% (force necessary to extend the specimen by 50% of its original size), at 100% and at 300%. The higher the value measured during the tensile test, and the better the material characteristics. In the fields of seal, a high modulus of elasticity is preferable, as it ensures:



Proprietà fisiche e meccaniche degli elastomeri
Elastomers physical and mechanical proprieties

- elevata forza del labbro contro le superfici a contatto, in caso di tenuta statica e dinamica
- maggiore resistenza all'estrusione.

La tensione (o allungamento), come mostra il grafico, è la deformazione elastica che il materiale può subire senza che si verifichi irreversibilità o rottura ed è un parametro inversamente proporzionale alla durezza del materiale.

Per quanto riguarda il carico di rottura (tenacità), è misurata la quantità di forza che il provino può assorbire per superare la fase elastica, lacerarsi fino alla rottura e assumere una forma irreversibile.

Il modulo elastico (misurato in unità di sforzo divise per unità di allungamento: N/cm^2) è dunque un indicatore fondamentale sia per la tenacità della tenuta sia per la repulsione all'estrusione.

- *high lip force against the mating surfaces, both in dynamic and static sealing*
- *higher resistance to extrusion.*

Moreover, as shown in the diagram on the side, under tension (elongation) we understand the elastic deformation that the test material can undergo without suffering breaking or irreversible effects. Elongation is a parameter inversely proportional to the material hardness.

This modulus is a key indicator both for the seal toughness and its resistance to extrusion.

The modulus is measured calculating the stress and dividing it by the elongation, therefore is measured in stress units divided by elongation units: N/cm^2 . Concerning the ultimate tensile stress (toughness), it is measured the force required by a specimen to exceed the elastic phase and tear to break, thus taking an irreversible shape.

Fig.6: curva fatica
 Pic.6: tension curve

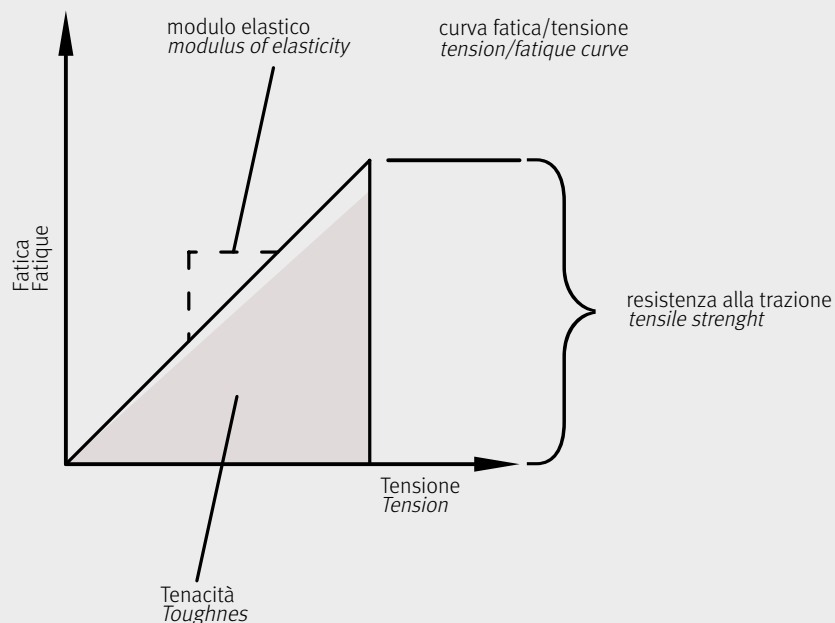

Resistenza all'abrasione

Altra caratteristica fondamentale nella determinazione della tenuta è la resistenza all'abrasione.

A differenza della resistenza al taglio, che avviene in un preciso momento, la resistenza all'abrasione è un fenomeno che si manifesta nel tempo, dovuto a uno sfregamento fra superfici a contatto.

La prova per valutare la resistenza avviene con un rullo di carta vetrata sul quale si sfrega il provino per un tempo prefissato. Si misura il peso prima e dopo il test e si esprime, in percentuale rispetto al peso iniziale, la differenza tra i due dati. Più il valore è basso, migliore è la resistenza dell'elastomero all'abrasione.

Lacerazione e usura

La resistenza alla lacerazione di un elastomero è un parametro molto importante per le applicazioni in cui il manufatto è soggetto a trazione o a rischio di tagli superficiali capaci di innescare lacerazioni al manufatto stesso.

Abrasion resistance

Another essential characteristic to specify a seal is the abrasion resistance.

Unlike shearing stress, which occurs at a given time, abrasion occurs over time, due to the rubbing between mating surfaces.

To evaluate the abrasion resistance, a test is carried out, where a specimen rubs over a sandpaper roll for a given period of time. The weight is measured before and after the test and the difference between the measurements is expressed in percentage compared to the initial weight. The lower the value, and the better the abrasion resistance of the elastomer.

Tear and wear

The tearing resistance of an elastomer is very important for all applications in which an item is subject to traction, particularly for those where there is a risk of significant surface cuts, that could easily induce tears, resulting in the item complete deterioration.

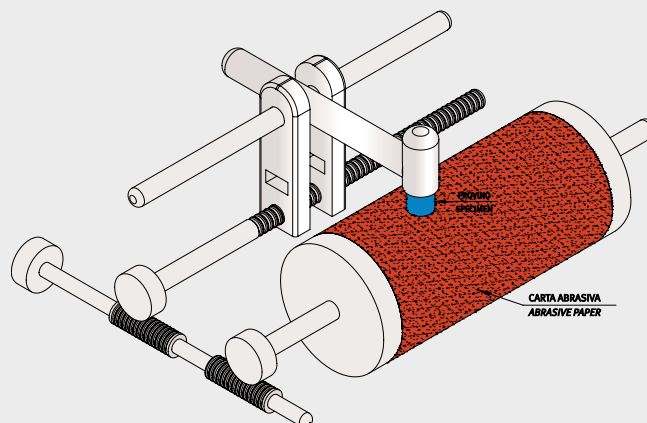

Fig.7: macchina per test di abrasione
 Pic.7: abrasion test machine



Altrettanto importante è la determinazione della resistenza all'usura necessaria per una corretta valutazione di progetto in tutte le applicazioni di tenute dinamiche.

I fattori in gioco per la determinazione della resistenza di un elastomero sono essenzialmente: il tipo di polimero, la durezza, la finitura superficiale, la lubrificazione, le velocità relative e l'ambiente di funzionamento.

Una buona resistenza è fondamentale anche durante le fasi di lavorazione (durante lo stampaggio agevola il distacco dallo stampo) e di montaggio dove previene lacerazioni.

Resilienza o rimbalzo

La resilienza o rimbalzo rappresenta la capacità di un elastomero di recuperare forma e grandezza originali dopo una deformazione temporanea. La prova di resilienza prevede il lancio di un pendolo contro un provino fissato alle due estremità con staffe. L'altezza a cui il pendolo rimbalza è poi calcolata come percentuale rispetto all'altezza di caduta iniziale.

Determining the wear resistance is essential for a correct project evaluation in dynamic sealing applications.

The factors involved are: polymer type; hardness; surface finishing; lubrication; relative speeds; operating environment.

It deals with the resistance a material opposes to cut initiating, when a tension stress is applied, and is measured in kN/m (kN per meter).

It is a very significant parameter that shall be taken into account also during the item processing phases and the installation in its seat. A good resistance in fact, facilitates the removal from mould during moulding, and prevents tears during mounting.

Resilience or rebound

The resilience, or rebound, represents the ability of an elastomer to recover its original size and shape after a temporary deformation stress. The resilience test is carried out by dropping a plunger on a specimen. The plunger rebound height is then calculated as percentage of the initial dropping height.

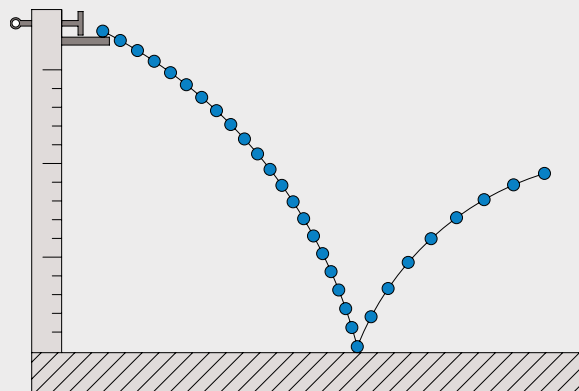

Fig.8: schema curva test resilienza o rimbalzo
 Pic.8: resilience or rebound's test curve

Attrito e lavorazione delle sedi

Friction and grooves machining

Attrito e assorbimento di potenza

L'attrito dovuto allo strisciamento sulla superficie dell'albero o sulla parete interna del cilindro contro lo spigolo di tenuta dà luogo a dissipazione di energia. E per contenerla nei giusti limiti occorre impostare correttamente:

- la geometria e il materiale del labbro di tenuta
- il grado di rugosità delle superfici e la loro finitura
- la pressione d'esercizio
- la velocità
- la viscosità del lubrificante.

È molto importante ridurre l'attrito al minimo perché generalmente causa calore, usura, perdite e riduce l'efficienza del sistema di tenute.

Per la funzionalità dell'anello di tenuta è fondamentale anche il carico radiale. Un eccessivo carico provoca infatti un forte attrito con alti assorbimenti di potenza e rapide usure. La durata e l'efficacia di una guarnizione dipendono dalla qualità della superficie dell'area di contatto dove graffi, fori, porosità e segni di utensili non sono ammessi, soprattutto dove scorre dinamicamente la guarnizione. I parametri utilizzati per definire la finitura sono Ra, Rt, RMAX e sono conformi alla ISO 4287/1. La tabella 12 evidenzia l'inopportunità di considerare i soli valori di Ra e Rt per valutare la guarnizione da adottare.

I picchi superficiali mostrano che a parità di valori Ra e Rt il profilo con minori asperità (v. RMR) presenta, con la guarnizione, una maggiore superficie di contatto con evidente beneficio della durata. Una scelta accurata delle rugosità dei componenti del cilindro consente di salvaguardare la longevità della tenuta. Superfici con un elevato grado di rugosità comportano un maggiore attrito con conseguente deterioramento e usura delle tenute.

Friction and power consumption

Sliding friction on the shaft surface or on the cylinder inside wall, against the sealing lip, results in energy dissipation. To keep energy dissipation within correct limits, the following parameters shall be properly set:

- *sealing lip geometry and material*
- *surfaces roughness degree and therefore finishing*
- *operating pressure*
- *speed*
- *lubricant viscosity.*

Minimizing the friction is of paramount importance, as it generally causes:

- *heat*
- *wear*
- *leakage.*

Basically a reduced efficiency of the sealing system. The radial load is an essential factor for the sealing ring efficiency. An excessive radial load causes high friction levels, resulting in high power consumption and rapid wear. The seal life and efficiency depend on the surface quality of the contact area. Scratches, holes, porosity, tooling marks are not admissible. It is very important to pay close attention to the surface quality, in particular in the area where the seal slides dynamically. The parameters used to specify the finishing are Ra, Rt, RMAX and conform to the standard ISO 4287/1. Table 12 highlights clearly that, considering only the values for Ra and Rt is not enough to identify the most suitable seal. If the surfaces involved feature a high roughness degree, friction will increase, resulting in the seal deterioration and wear.

The surface peaks show that, Ra and Rz values being equal, the profile featuring less unevenness (see RMR) offers a larger contact area with the seal, which is obviously beneficial for the seal duration. A careful choice of the cylinder components roughness supports the seal durability.



Attrito e lavorazione delle sedi
Friction and grooves machining

Fig.9-A
Pic.9-A

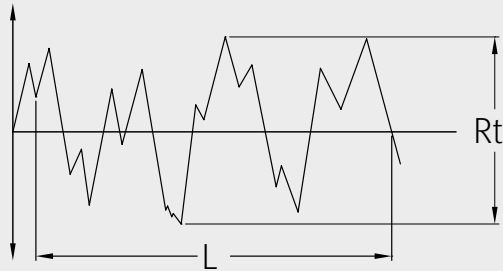

R_t : altezza totale del profilo
 R_t : total height of the profile
 R_{MR} : percentuale della lunghezza portante
 R_{MR} : percentage of total length of the profile

Fig.9-B
Pic.9-B

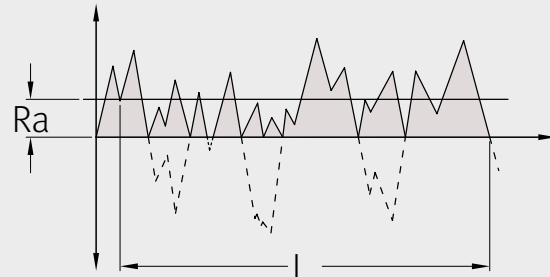

R_a : scostamento aritmetico medio del profilo vaultato
 R_a : roughness average value of the measured profile.

Fig.10: perdite per effetto di attrito a temperatura ambiente
Pic.10: leaks due the friction room temperature

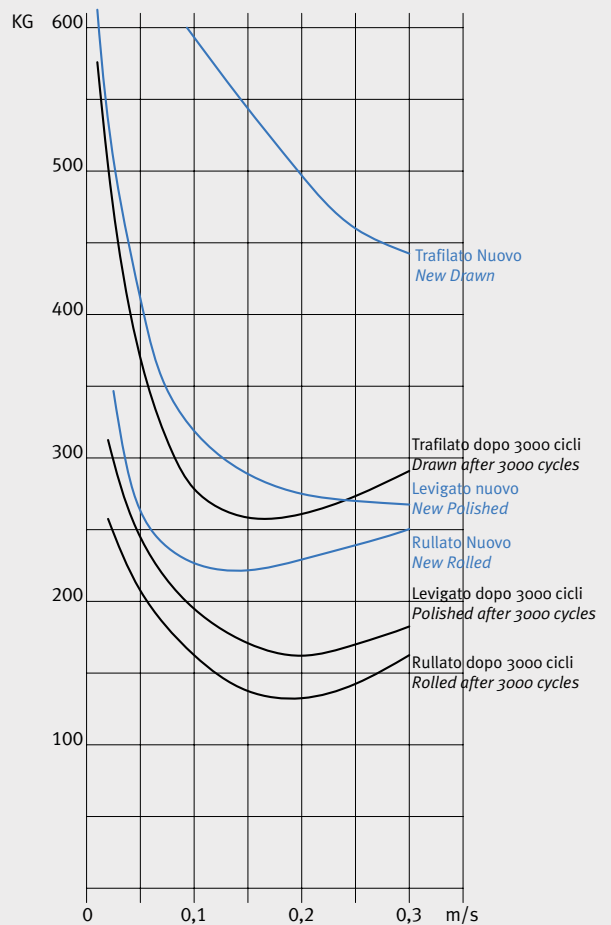

Tab. 13 - rugosità superficiale / surface roughness		
	superficie di scorrimento consigliata per il poliuretano sliding surface recommended for polyurethane	superficie della cava statica surface
R_{max}	1,00 - 4,00	< 10,0
$R_{t\text{ DIN}}$	0,63 - 2,50	< 6,3
R_a	0,10 - 0,60	< 1,6

Indicazione di rugosità nelle lavorazioni

Per ottenere un accoppiamento fra le varie parti in movimento e preservare le tenute durante il loro ciclo di lavorazione, Artic Seals consiglia di attestarsi sui seguenti gradi di rugosità:

stelo 0,1 - 0,4 $\mu\text{m Ra}$
ottenibile da finitura come rettificazione, cromatura, pelatura

camicia interna 0,2 - 0,6 $\mu\text{m Ra}$
ottenibile da finitura come levigatura, alesatura, rullatura.

Occorre considerare che, a parità di grado di rugosità, i profili superficiali ottenibili dalle varie tipologie di lavorazione saranno significativamente differenti tra loro, come mostrano gli schemi sotto riportati. Per questa ragione suggeriamo di attenersi a un profilo superficiale, come mostrato in fig. 12.

Quando il grado di rugosità ha un valore relativamente basso, ma le creste si presentano come evidenziato in fig.11 (lucido di trafilatura con R_{MR} 15%), si consiglia di adottare tenute in PTFE caricato a bronzo ed evitare gomme e/o poliuretani.

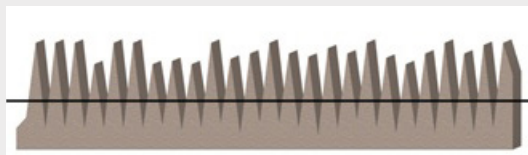

Fig.11-Pic.11: $R_a = 0,4 \mu\text{m}/16 \mu\text{inc}$ $R_{MR} = 15\%$

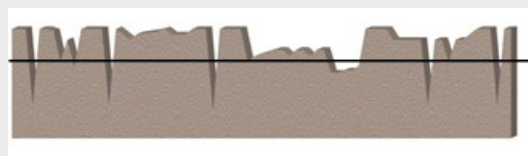

Fig.12-Pic.12: $R_a = 0,4 \mu\text{m}/16 \mu\text{inc}$ $R_{MR} = 75\%$

Surface roughness

To obtain the right fitting among the different moving parts, while protecting the seal during its operating cycle, Artic recommends the following roughness degrees:

Rod = 0,1 ÷ 0,4 $\mu\text{m Ra}$
achieved through finishing typologies like: grinding, chrome, peeling

Inside liner = 0,2 ÷ 0,6 $\mu\text{m Ra}$
achieved through finishing typologies like: honing, boring, rolling.

It should also be considered that, roughness degree being equal, the surface profiles can significantly vary, depending on the machining.

For this reason, it is advisable to choose a surface roughness that enables a profile similar to the one shown in Pic.12.

If the roughness degree is relatively low, but peaks appear as shown in Pic.11 (Bright drawn with R_{MR} 15%) it is recommended Bronze-filled PTFE seals and advises against rubber and/or Polyurethanes.

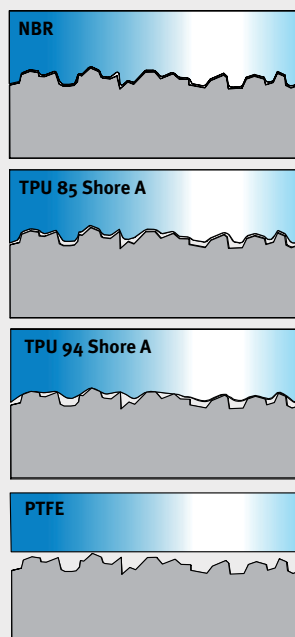

Fig.13: esempi di appoggio/contatto di diversi materiali a parità di valore di rugosità della superficie lavorata

Pic.13: example of contact profile of different material on machined surface having same roughness value



Dimensionamento delle sedi, gioco di accoppiamento

L'ampiezza massima consentita del gioco di accoppiamento tra testata/stelo e pistone/camicia deve essere attentamente valutata affinché non intervengano problemi di estrusione nella parte posteriore della guarnizione (v. fig. 14). Tale gioco dipende principalmente dalla durezza del materiale con cui è costruita la tenuta, dalla pressione massima presente nel cilindro, dalla temperatura e dalla resistenza al carico radiale degli anelli di guida. La tabella 4 mostra il gioco di accoppiamento che si deve mantenere tra stelo/testata e tra pistone/camicia.

Il test è stato eseguito con olio a temperatura a 60° C con materiale 93 Shore A. La figura 15 mostra i valori indicativi del gioco massimo ammesso in funzione della pressione di esercizio utilizzando guarnizioni di materiale e durezza differenti.

Groove dimensioning, Fitting clearance

The maximum admissible fitting clearance value between head/rod and piston/liner shall be carefully evaluated, in order to prevent extrusion problems in the seal rear area, (see Pic. 14). The clearance depends mainly on the seal material hardness, the maximum pressure in the cylinder, the temperature and the radial load resistance of the guide rings. Table 4 lists the fitting clearance values that shall be maintained between rod/head and piston/liner. The test has been carried out with oil at 60° C, using a material featuring a hardness value equal to 93 Shore A.

Picture 15 shows the reference values for the maximum admissible clearance as a function of the operating pressure, using seals in different materials and featuring different hardness degrees.

Tab.40 gioco di accoppiamento / coupling clearance	
pressione / pressure BAR	G mm
50	0,50
100	0,30
200	0,20
300	0,10
400	0,05

Fig.14 / Pic.14

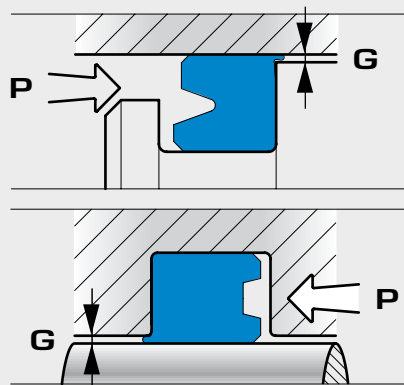

Attrito e lavorazione delle sedi
Friction and groove machining

Fig.15 / Pic.15

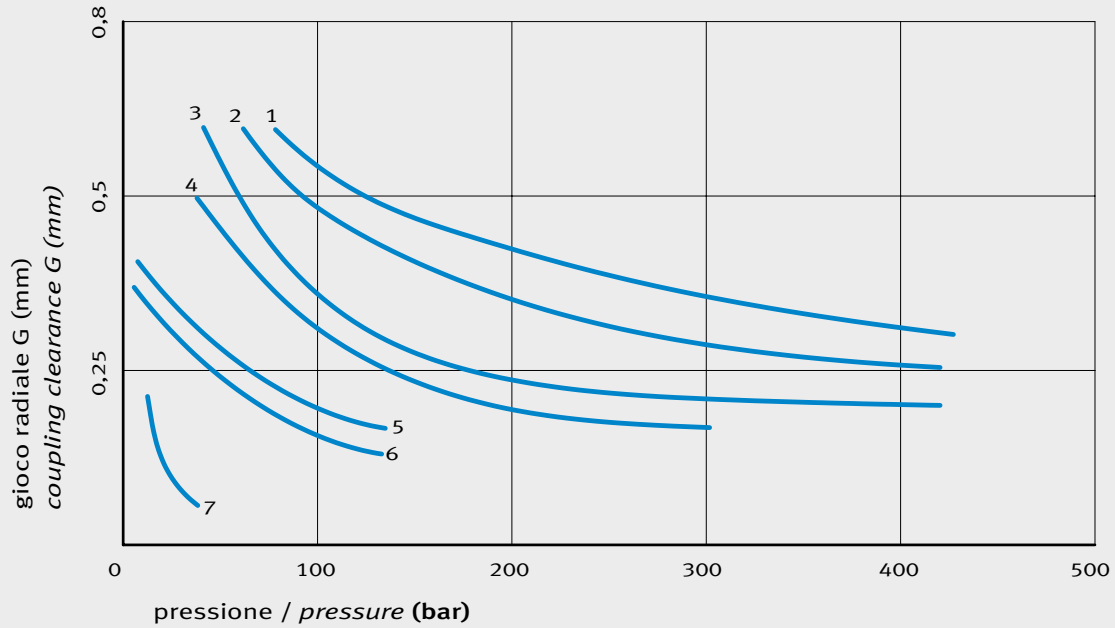

- 1 - poliuretano 93 Shore A con anello antiestrusione
- 2 - poliuretano 98 Shore A
- 3 - poliuretano 93 Shore A
- 4 - poliuretano 90 Shore A
- 5 - poliuretano 85 Shore A
- 6 - NBR 90 Shore A
- 7 - NBR 70 Shore A

- 1 - polyurethane 93 Shore A with antiextrusion ring
- 2 - polyurethane 98 Shore A
- 3 - polyurethane 93 Shore A
- 4 - polyurethane 90 Shore A
- 5 - polyurethane 85 Shore A
- 6 - NBR 90 Shore A
- 7 - NBR 70 Shore A



Analisi Elementi Finiti

Finite Elements Analysis

Metodo FEA

Il metodo degli elementi finiti si basa sul concetto di descrivere lo stato di deformazione di un sistema continuo mediante funzioni di spostamento, definite in piccole regioni del “continuum”. In quest’ottica le soluzioni sono formulate per ciascuna unità e combinate per ottenere la soluzione del corpo o della struttura originale.

L’analisi degli elementi finiti (FEA) consente di calcolare il comportamento strutturale di un sistema applicando il concetto della discretizzazione, ossia la suddivisione della struttura iniziale in un sistema equivalente di strutture più piccole o unità, tali che il loro assemblaggio dia luogo alla struttura reale. Si ha quindi la definizione di una griglia geometrica (mesh) tramite la quale il modello geometrico è diviso in tanti piccoli elementi di facile calcolo. Il metodo degli E.F. è un metodo approssimato e la convergenza dell’approssimazione con la soluzione esatta deriva da numerosi parametri, ma se l’impostazione è corretta l’approssimazione è molto vicina alla soluzione esatta.

Tramite l’analisi degli elementi finiti, completamente integrata nel software CAD, Artic Seals ottimizza e convalida in modo rapido ed efficiente tutte le fasi di progettazione verificando qualità, prestazioni e sicurezza del prodotto. La FEA diviene così una parte del processo di progettazione che riduce la necessità di costosi prototipi ed elimina rilavorazioni e ritardi. L’applicativo in uso utilizza la formulazione dello spostamento del metodo degli elementi finiti per calcolare gli spostamenti, le deformazioni e le

FEA method

The finite elements method is based on the concept of describing the state of deformation of a continuous system by means of displacement functions, defined in small areas of the “continuum”. In this perspective, solutions are formulated for each unit and combined to obtain the body or original structure solution.

Finite element Analysis (FEA) enables to calculate the structural behaviour of a system applying the core concept of discretization, i.e. dividing the initial structure in an equivalent system of smaller structures or units, such as their assembling results in the real structure. We get then a geometrical mesh, through which the geometrical model is divided into many small, easy-to-calculate items. This equates to describe a structure using a finite numbers of points (called nodes).

The finite elements analysis is not an exact method, but approximate. The convergence of the approximation with the exact solution derives from a variety of parameters. If the model is set in correct form, the approximations achieved are anyway very close to the exact solution.

Applying the FEA fully integrated in our CAD software, we can optimize and validate each design phase quickly and easily, to check the product quality, performance and safety. The FEA can therefore be considered as a normal part of the designing process, reducing the need of costly prototypes, eliminating reworking and delays.

sollecitazioni dei componenti sottoposti a carichi interni ed esterni. La geometria sottoposta ad analisi è suddivisa utilizzando elementi tetraedrici (3D), triangolari (2D) ed elementi trave, quindi è risolta attraverso un solutore Direct Sparse o iterativo.

L'analisi consente inoltre di:

- ridurre prototipi e collaudi fisici
- prevedere e migliorare prestazioni e affidabilità di prodotto
- valutare diversi progetti e materiali
- ottimizzare i progetti e ridurre il consumo di materiali.

The application in use at Artic Seals, using the formulation of the displacement of the finite element method to calculate displacements, strains and stresses of the components subjected to internal and external loads. The geometry is divided subjected to analysis using tetrahedral elements (3D) triangular elements (2D) and beam elements, then it is resolved through a Direct Sparse solver or iterative.

In addition, we can:

- *reduce the need for physical prototypes and testing*
- *predict and improve the performance and reliability of a product*
- *evaluate different designs and materials*
- *optimize designs and reduce the consumption of materials.*

Fig.16: FEA guarnizione stelo montata in sede in assenza di pressione

Pic.16: FEA of rod seal in groove without pressure

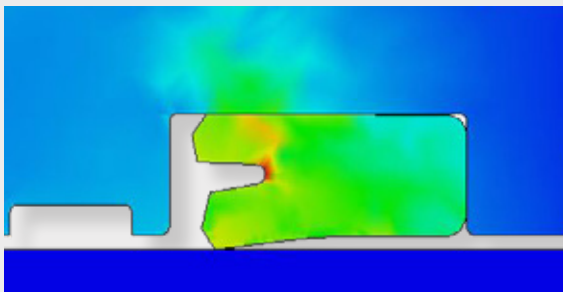
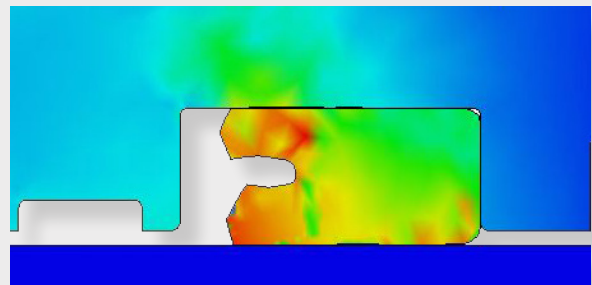

Fig.17: FEA guarnizione stelo montata in sede pressione di esercizio

Pic.17: FEA of rod seal in groove with exercise pressure





Tolleranze

Tolerances

Tab. 15 - Tabella tolleranze - *Tolerances table*

dimensioni nominali <i>nominal dimensions</i> Ø mm		albero base <i>rod</i> (0,001 mm)								foro base <i>bore</i> (0,001 mm)				
da <i>from</i>	a <i>to</i>	e9	f7	f8	f9	h8	h9	h10	h11	H7	H8	H9	H10	H11
1,6	3	-14 -39	-6 -16	-6 -20	-6 -31	0 -14	0 -25	0 -40	0 -60	+9 0	+14 0	+25 0	+40 0	+60 0
3	6	-20 -50	-10 -22	-10 -28	-10 -40	0 -18	0 -30	0 -48	0 -75	+12 0	+18 0	+30 0	+48 0	+75 0
6	10	-25 -61	-13 -28	-13 -35	-13 -49	0 -22	0 -36	0 -58	0 -90	+15 0	+22 0	+36 0	+58 0	+90 0
10	18	-32 -75	-16 -34	-16 -43	-16 -59	0 -27	0 -43	0 -70	0 -110	+18 0	+27 0	+43 0	+70 0	+110 0
18	30	-40 -92	-20 -41	-20 -53	-20 -72	0 -33	0 -52	0 -84	0 -130	+21 0	+33 0	+52 0	+84 0	+130 0
30	50	-50 -112	-25 -50	-25 -64	-25 -87	0 -39	0 -62	0 -100	0 -160	+25 0	+39 0	+62 0	+100 0	+160 0
50	80	-60 -134	-30 -60	-30 -76	-30 -104	0 -46	0 -74	0 -120	0 -190	+30 0	+46 0	+74 0	+120 0	+190 0
80	120	-72 -159	-36 -71	-36 -90	-36 -123	0 -54	0 -87	0 -140	0 -220	+35 0	+54 0	+87 0	+140 0	+220 0
120	180	-85 -185	-43 -83	-43 -106	-43 -143	0 -63	0 -100	0 -160	0 -250	+40 0	+63 0	+100 0	+160 0	+250 0
180	250	-100 -215	-50 -96	-50 -122	-50 -165	0 -72	0 -115	0 -185	0 -290	+46 0	+72 0	+115 0	+185 0	+290 0
250	315	-110 -240	-56 -108	-56 -137	-56 -186	0 -81	0 -130	0 -210	0 -320	+52 0	+81 0	+130 0	+210 0	+320 0
315	400	-125 -265	-62 -119	-62 -151	-62 -212	0 -89	0 -140	0 -230	0 -360	+57 0	+89 0	+140 0	+230 0	+360 0

Conversione dimensioni lineari Linear dimensions conversion

Tab. 16 - Tabella conversione dimensioni lineari / *Linear dimensions conversion tab*

Pollici / Inch		0 1 2 3 4 5 6 7 8 9 10										
Fraction	Decimal											
0	0.000000	0.000	25.400	50.800	76.200	101.600	127.000	152.400	177.800	203.200	228.600	254.000
1/64	0.015625	0.397	25.797	51.197	76.597	101.997	127.397	152.797	178.197	203.597	228.997	254.397
1/32	0.031250	0.794	26.194	51.594	76.994	102.394	127.794	153.194	178.594	203.994	229.394	254.794
3/64	0.046875	1.191	26.591	51.991	77.391	102.791	128.191	153.591	178.991	204.391	229.791	255.191
1/16	0.062500	1.588	26.988	52.388	77.788	103.188	128.588	153.988	179.388	204.788	230.188	255.588
5/64	0.078125	1.984	27.384	52.784	78.184	103.584	128.984	154.384	179.784	205.184	230.584	255.984
3/32	0.093750	2.381	27.781	53.181	78.581	103.981	129.381	154.781	180.181	205.581	230.981	256.381
7/64	0.109375	2.778	28.178	53.578	78.978	104.378	129.778	155.178	180.578	205.978	231.378	256.778
1/8	0.125000	3.175	28.575	53.975	79.375	104.775	130.175	155.575	180.975	206.375	231.775	257.175
9/64	0.140625	3.572	28.972	54.372	79.772	105.172	130.572	155.972	181.372	206.772	232.172	257.572
5/32	0.156250	3.969	29.369	54.769	80.169	105.569	130.969	156.369	181.769	207.169	232.569	257.969
11/64	0.171875	4.366	29.766	55.166	80.566	105.966	131.366	156.766	182.166	207.566	232.966	258.366
3/16	0.187500	4.762	30.162	55.562	80.962	106.362	131.762	157.162	182.562	207.962	233.362	258.762
13/64	0.203125	5.159	30.559	55.959	81.359	106.759	132.159	157.559	182.959	208.359	233.759	259.159
7/32	0.218750	5.556	30.956	56.356	81.756	107.156	132.556	157.956	183.356	208.756	234.156	259.556
15/64	0.234375	5.953	31.353	56.753	82.153	107.553	132.953	158.353	183.753	209.153	234.553	259.953
1/4	0.250000	6.350	31.750	57.150	82.550	107.950	133.350	158.750	184.150	209.550	234.950	260.350
17/64	0.265625	6.747	32.147	57.547	82.947	108.347	133.747	159.147	184.547	209.947	235.347	260.747
9/32	0.281250	7.144	32.544	57.944	83.344	108.744	134.144	159.544	184.944	210.344	235.744	261.144
19/64	0.296875	7.541	32.941	58.341	83.741	109.141	134.541	159.941	185.341	210.741	236.141	261.541
5/16	0.312500	7.938	33.338	58.738	84.138	109.538	134.938	160.338	185.738	211.138	236.538	261.938
21/64	0.328125	8.334	33.734	59.134	84.534	109.934	135.334	160.734	186.134	211.534	236.934	262.334
11/32	0.343750	8.731	34.131	59.531	84.931	110.331	135.731	161.131	186.531	211.931	237.331	262.731
23/64	0.359375	9.128	34.528	59.928	85.328	110.728	136.128	161.528	186.928	212.328	237.728	263.128
3/8	0.375000	9.525	34.925	60.325	85.725	111.125	136.525	161.925	187.325	212.725	238.125	263.525
25/64	0.390625	9.922	35.322	60.722	86.122	111.522	136.922	162.322	187.722	213.122	238.522	263.922
13/32	0.406250	10.319	35.719	61.119	86.519	111.919	137.319	162.719	188.119	213.519	238.919	264.319
27/64	0.421875	10.716	36.116	61.516	86.916	112.316	137.716	163.116	188.516	213.916	239.316	264.716
7/16	0.437500	11.112	36.512	61.912	87.312	112.712	138.112	163.512	188.912	214.312	239.712	265.112
29/64	0.453125	11.509	36.909	62.309	87.709	113.109	138.509	163.909	189.309	214.709	240.109	265.509
15/32	0.468750	11.906	37.306	62.706	88.106	113.506	138.906	164.306	189.706	215.106	240.506	265.906
31/64	0.484375	12.303	37.703	63.103	88.503	113.903	139.303	164.703	190.103	215.503	240.903	266.303
1/2	0.500000	12.700	38.100	63.500	88.900	114.300	139.700	165.100	190.500	215.900	241.300	266.700
33/64	0.515625	13.097	38.497	63.897	89.297	114.697	140.097	165.497	190.897	216.297	241.697	267.097
17/32	0.531250	13.494	38.894	64.294	89.694	115.094	140.494	165.894	191.294	216.694	242.094	267.494
35/64	0.546875	13.891	39.291	64.691	90.091	115.491	140.891	166.291	191.691	217.091	242.491	267.891
9/16	0.562500	14.288	39.688	65.088	90.488	115.888	141.288	166.688	192.088	217.488	242.888	268.288
37/64	0.578125	14.684	40.084	65.484	90.884	116.284	141.684	167.084	192.484	217.884	243.284	268.684
19/32	0.593750	15.081	40.481	65.881	91.281	116.681	142.081	167.481	192.881	218.281	243.681	269.081
39/64	0.609375	15.478	40.878	66.278	91.678	117.078	142.478	167.878	193.278	218.678	244.078	269.478
5/8	0.625000	15.875	41.275	66.675	92.075	117.475	142.875	168.275	193.675	219.075	244.475	269.875
41/64	0.640625	16.272	41.672	67.072	92.472	117.872	143.272	168.672	194.072	219.472	244.872	270.272
21/32	0.656250	16.669	42.069	67.469	92.869	118.269	143.669	169.069	194.469	219.869	245.269	270.669
43/64	0.671875	17.066	42.466	67.866	93.266	118.666	144.066	169.466	194.866	220.266	245.666	271.066
11/16	0.687500	17.462	42.862	68.262	93.662	119.062	144.462	169.862	195.262	220.662	246.062	271.462
45/64	0.703125	17.859	43.259	68.659	94.059	119.459	144.859	170.259	195.659	221.059	246.459	271.859
23/32	0.718750	18.256	43.656	69.056	94.456	119.856	145.256	170.656	196.056	221.456	246.856	272.256
47/64	0.734375	18.653	44.053	69.453	94.853	120.253	145.653	171.053	196.453	221.853	247.253	272.653
3/4	0.750000	19.050	44.450	69.850	95.250	120.650	146.050	171.450	196.850	222.250	247.650	273.050
49/64	0.765625	19.447	44.847	70.247	95.647	121.047	146.447	171.847	197.247	222.647	248.047	273.447
25/32	0.781250	19.844	45.244	70.644	96.044	121.444	146.844	172.244	197.644	223.044	248.444	273.844
51/64	0.796875	20.241	45.641	71.041	96.441	121.841	147.241	172.641	198.041	223.441	248.841	274.241
13/16	0.812500	20.638	46.038	71.438	96.838	122.238	147.638	173.038	198.438	223.838	249.238	274.638
53/64	0.828125	21.034	46.434	71.834	97.234	122.634	148.034	173.434	198.834	224.234	249.634	275.034
27/32	0.843750	21.431	46.831	72.231	97.631	123.031	148.431	173.831	199.231	224.631	250.031	275.431
55/64	0.859375	21.828	47.228	72.628	98.028	123.428	148.828	174.228	199.628	225.028	250.428	275.828
7/8	0.875000	22.225	47.625	73.025	98.425	123.825	149.225	174.625	200.025	225.425	250.825	276.225
57/64	0.890625	22.622	48.022	73.422	98.822	124.222	149.622	175.022	200.422	225.822	251.222	276.622
29/32	0.906250	23.019	48.419	73.819	99.219	124.619	150.019	175.419	200.819	226.219	251.619	277.019
59/64	0.921875	23.416	48.816	74.216	99.616	125.016	150.416	175.816	201.216	226.616	252.016	277.416
15/16	0.937500	23.812	49.212	74.612	100.012	125.412	150.812	176.212	201.612	227.012	252.412	277.812
61/64	0.953125	24.209	49.609	75.009	100.409	125.809	151.209	176.609	202.009	227.409	252.809	278.209
31/32	0.968750	24.606	50.006	75.406	100.806	126.206	151.606	177.006	202.406	227.806	253.206	278.606
63/64	0.984375	25.003	50.403	75.803	101.203	126.603	152.003	177.403	202.803	228.203	253.603	279.003



Conversione pressioni Bar/Psi

Pressures conversion Bar/Psi

Tab. 17 - Tabella conversione pressioni / Pressures conversion chart

Bar	Psi	Bar	Psi	Bar	Psi	Bar	Psi
1	14,50	26	377,09	51	739,69	76	1102,28
2	29,00	27	391,60	52	754,19	77	1116,79
3	43,51	28	406,10	53	768,70	78	1131,29
4	58,01	29	420,60	54	738,20	79	1145,79
5	72,51	30	453,11	55	797,70	80	1160,30
6	87,02	31	449,61	56	818,21	81	1174,80
7	101,52	32	464,12	57	826,71	82	1189,30
8	116,03	33	478,62	58	841,21	83	1203,81
9	130,53	34	493,12	59	855,72	84	1218,31
10	145,03	35	507,63	60	870,22	85	1232,82
11	159,54	36	522,13	61	884,73	86	1247,32
12	174,04	37	536,63	62	899,23	87	1261,82
13	188,54	38	551,14	63	913,73	88	1276,33
14	203,05	39	565,64	64	928,24	89	1290,83
15	217,55	40	580,15	65	842,74	90	1305,33
16	232,06	41	594,65	66	957,24	100	1450,37
17	246,56	42	609,15	67	971,75	125	1812,97
18	261,06	43	623,66	68	986,25	150	2175,56
19	275,57	44	638,16	69	100,76	175	2538,16
20	290,07	45	652,66	70	1015,26	200	2900,75
21	304,57	46	667,17	71	1029,76	250	3625,94
22	319,08	47	681,67	72	1044,27	300	4351,13
23	333,58	48	696,18	73	1058,77	500	7251,88
24	348,09	49	710,68	74	1073,27	750	10877,83
25	362,59	50	725,18	75	1087,78	1000	14503,77

Conversione temperature °C/°F

Temperature conversion °C/°F

Tab. 18 Tabella conversione temperature / Temperature conversion chart

Celsius	Fahrenheit	Celsius	Fahrenheit	Celsius	Fahrenheit	Celsius	Fahrenheit	Celsius	Fahrenheit
-169	-273	-7.8	18	17.8	64	93	200	343	650
-168	-270	-7.2	19	18.3	65	99	210	349	660
-162	-260	-6.7	20	18.9	66	100	212	354	670
-157	-250	-6.1	21	19.4	67	104	220	360	680
-151	-240	-5.6	22	20	68	110	230	366	690
-146	-230	-5	23	20.6	69	116	240	371	700
-140	-220	-4.4	24	21.1	70	121	250	377	710
-134	-210	-3.9	25	21.7	71	127	260	382	720
-129	-200	-3.3	26	22.2	72	132	270	388	730
-123	-190	-2.8	27	22.8	73	138	280	393	740
-118	-180	-2.2	28	23.3	74	143	290	399	750
-112	-170	-1.7	29	23.9	75	149	300	404	760
-107	-160	-1.1	30	24.4	76	154	310	410	770
-101	-150	-0.6	31	25	77	160	320	416	780
-96	-140	0	32	25.6	78	166	330	421	790
-90	-130	0.6	33	26.1	79	171	340	427	800
-84	-120	1.1	34	26.7	80	177	350	432	810
-79	-110	1.7	35	27.2	81	182	360	438	820
-73	-100	2.2	36	27.8	82	188	370	443	830
-68	-90	2.8	37	28.3	83	193	380	449	840
-62	-80	3.3	38	28.9	84	199	390	454	850
-57	-70	3.9	39	29.4	85	204	400	460	860
-51	-60	4.4	40	30	86	210	410	466	870
-46	-50	5	41	30.6	87	216	420	471	880
-40	-40	5.6	42	31.1	88	221	430	477	890
-34	-30	6.1	43	31.7	89	227	440	482	900
-29	-20	6.7	44	32.2	90	232	450	488	910
-23	-10	7.2	45	32.8	91	238	460	493	920
-17.8	0	7.8	46	33.3	92	243	470	499	930
-17.2	1	8.3	47	33.9	93	249	480	504	940
-16.7	2	8.9	48	34.4	94	254	490	510	950
-16.1	3	9.4	49	35	95	260	500	516	960
-15.6	4	10	50	35.6	96	266	510	521	970
-15	5	10.6	51	36.1	97	271	520	527	980
-14.4	6	11.1	52	36.7	98	277	530	532	990
-13.9	7	11.7	53	37.2	99	282	540	538	1000
-13.3	8	12.2	54	37.8	100	288	550	549	1020
-12.8	9	12.8	55	43	110	293	560	560	1040
-12.2	10	13.3	56	49	120	299	570	571	1060
-11.7	11	13.9	57	54	130	304	580	582	1080
-11.1	12	14.4	58	60	140	310	590	593	1100
-10.6	13	15	59	66	150	316	600	604	1120
-10	14	15.6	60	71	160	321	610	616	1140
-9.4	15	16.1	61	77	170	327	620	627	1160
-8.9	16	16.7	62	82	180	332	630	638	1180
-8.3	17	17.2	63	88	190	338	640	649	1200



Unità di misura e principali grandezze

Units and main sizes

Tab.19 *Lunghezza - Distanza*

Grandezza	simbolo	conversioni
metro	m	1 m = 0,001 km = 39,37 in = 3,28 ft = 1,09 yd
centimetro	cm	1 cm = 0,01 m = 0,3937 in = 0,0328 ft = 0,0109 yd
chilometro	km	1 km = 1000 m = 1093,61 yd = 0,5396 naut mi = 0,62137 mi
inch (pollice)	1", in	1 in = 0,0833 ft = 0,0278 yd = 2,54 cm = 0,0254 m
foot (piede)	1', ft	1 ft = 12 in = 0,333 yd = 30,48 cm = 0,3048 m
yard (iarda)	yd	1 yd = 3 ft = 36 in = 91,44 cm = 0,9144 m
miglio marino	naut mi	1 naut mi = 1,853 km = 1'853,18 m = 2'026,67 yd = 1,151 mi
miglio terrestre US	mi	1 mi = 1,609 km = 1'609,35 m = 1'760 yd = 0,868 naut mi
hand (palmo)	hand	1 hand = 4 in = 0,3332 ft = 0,111 yd = 10,16 cm = 0,1016 m
span (spanna)	span	1 span = 9 in = 0,7497 ft = 0,25 yd = 22,86 cm = 0,2286 m

Tab.20 *Superficie - Area*

Grandezza	simbolo	conversioni
metro quadrato	m ²	1 m ² = 10'000 cm ² = 0,0001 ha = 1.550 in ² = 10,76 ft ² = 1,196 yd ²
centimetro quadrato	cm ²	1 cm ² = 0,0001 m ² = 0,155 in ² = 0,0011 ft ² = 0,00012 yd ²
kilometro quadrato	km ²	1 km ² = 1'000'000 m ² = 100 ha = 0,386 mi ² = 247,105 ac
ara	a	1a = 100 m ² = 0,01 ha = 1'076,39 ft ² = 119,599 yd ² = 0,0000386 mi ² = 0,024 ac
ettaro	ha	1 ha = 100 a = 10'000 m ² = 0,01 km ² = 107'639,1 ft ² = 0,0039 mi ² = 2,47 ac
square inch	in ²	1 in ² = 0,00694 ft ² = 6,4516 cm ²
square foot	ft ²	1 ft ² = 0,092 m ² = 144 in ² = 0,111 yd ²
square yard	yd ²	1 yd ² = 0,836 m ² = 8'361,27 cm ² = 9 ft ² = 1'296 in ² = 0,0002 ac
square mile	mi ²	1mi ² = 2,59 km ² = 259 ha = 640 ac
acre	ac	1 ac = 4'046,86 m ² = 0,0040 km ² = 0,40 ha = 40,47 a = 43.560 ft ² = 4840 yd ² = 0,00156 mi ²

Tab.21 *Volume*

Grandezza	simbolo	conversioni
metro cubo	m ³	1 m ³ = 1'000 dm ³ = 35,3146 ft ³ = 61'023,744 in ³ = 1,308 yd ³ = 264,20 galUS = 219,97 galUK
decimetro cubo; litro	dm ³	1 dm ³ = 1 l = 0,001 m ³ = 61,024 in ³ = 0,0353 ft ³ = 0,00131 yd ³ = 0,26417 galUS = 0,21997 galUK
centimetro cubo	cm ³ , cc	1 cm ³ = 0,001 dm ³ = 0,001 l = 0,061 in ³ = 0,000264 galUS = 0,00022gal UK
cubic inch	in ³	1 in ³ = 0,0000164 m ³ = 0,0164 dm ³ = 0,0005787 ft ³ = 0,0043 galUS = 0,0036 galUK
cubic foot	ft ³	1 ft ³ = 0,02832 m ³ = 28,32 dm ³ = 1'728 in ³ = 0,037 yd ³ = 7,48 galUS = 6,23 galUK
cubic yard	yd ³	1 yd ³ = 0,764 m ³ = 764,55 dm ³ = 46'656 in ³ = 27 ft ³ = 201,97 galUS = 168,18 galUK
gallon US	galUS	1 galUS = 0,00378 m ³ = 3,785 dm ³ = 231 in ³ = 0,134 ft ³ = 0,0049 yd ³ = 0,833 galUK
gallon UK	galUK	1 galUK = 0,00455 m ³ = 4,546 dm ³ = 277,42 in ³ = 0,16 ft ³ = 0,0059 yd ³ = 1,2 galUS

Tab.22 *Pressione*

Grandezza	simbolo	conversioni
pascal	Pa	1 Pa = 1 N/m ² 1 kPa = 0,01 bar = 0,1 N/cm ² = 0,10 mH ₂ O = 7,5 mmHg = 0,0099 atm = 0,145 psi = 0,02088 lbf/ft ² = 0,334 ftH ₂ O
bar	bar	1 bar = 100'000 Pa = 100 kPa = 1,0197 kg/cm ² = 10,198 mH ₂ O = 750 mmHg = 0,987 atm = 14,5 psi = 33,455 ftH ₂ O
millibar	mbar	1 mbar = 100 Pa = 0,010 mH ₂ O = 0,750 mmHg = 0,00102 kg/cm ² = 0,0145 psi = 2,088 lbf/ft ² = 0,033 ftH ₂ O
millimetri di mercurio	mmHg	1 mmHg = 133,322 Pa = 0,133 kPa = 0,00133 bar = 0,0136 mH ₂ O = 0,00131 atm = 0,00136 kg/cm ² = 0,01934 psi = 2,78 lbf/ft ² = 0,045 ftH ₂ O
atmosfera tecnica = kgf/cm ²	at, kg/cm ²	1 at = 1 kg/cm ² = 735,56 mmHg = 10 mH ₂ O = 98066,50 Pa = 98,067 kPa = 0,981 bar = 0,968 atm = 14,22 psi = 2048,16 lbf/ft ² = 32,81 ftH ₂ O
atmosfera metrica	atm	1 atm = 101'325 Pa = 760 mmHg = 1,033 at = 10,33 mH ₂ O = 1,01 bar = 14,696 psi = 2116,22 lbf/ft ² = 33,9 ftH ₂ O
metri colonna d'acqua	mH ₂ O	1 mH ₂ O = 9806 Pa = 0,09806 bar = 73,55 mmHg = 0,9806 N/cm ² = 0,09678 atm = 0,0999 at = 1,4224 psi = 204,8 lbf/ft ² = 3,28 ftH ₂ O
foot of water	ftH ₂ O	1 ftH ₂ O = 2988,87 Pa = 0,0299 bar = 0,3048 mH ₂ O = 22,419 mmHg = 0,0295 atm = 0,03048 kg/cm ² = 0,4335 psi = 62,42 lbf/ft ²
pounds per square inch	psi	1 psi = 6'894,76 Pa = 6,894 kPa = 0,069 bar = 0,703 mH ₂ O = 51,715 mmHg = 0,689 N/cm ² = 0,068 atm = 0,0703 kg/cm ² = 144 lbf/ft ² = 2,31 ftH ₂ O
pounds per square foot	lbf/ft ²	1 lbf/ft ² = 2'988,87 Pa = 2,99 kPa = 0,0299 bar = 0,3048 mH ₂ O = 22,418 mmHg = 0,299 N/cm ² = 0,0295 atm = 0,0305 at = 0,433 psi = 62,424 lbf/ft ²

Tab.23 *Portata in volume*

Grandezza	simbolo	conversioni
metri cubi al secondo	m ³ /s	1 m ³ /s = 60 m ³ /min = 3'600 m ³ /ora = 1'000 l/s = 60'000 l/min = 6'102'374,42 in ³ /s = 2'118,88 ft ³ /min = 15'850,32 gpm = 13'198,13 l gpm
metri cubi al minuto	m ³ /min	1 m ³ /min = 0,0167 m ³ /s = 60 m ³ /h = 16,67 l/s = 1'000 l/min = 35,31 ft ³ /min = 264,17 gpm = 219,97 l gpm
metro cubo all'ora	m ³ /h	1 m ³ /h = 0,000278 m ³ /s = 0,0167 m ³ /min = 0,28 l/s = 16,67 l/min = 1017,06 in ³ /min = 0,588 ft ³ /min = 4,40 gpm = 3,66 l gpm
litri al secondo	l/s	1 l/s = 0,001 m ³ /s = 0,06 m ³ /min = 3,6 m ³ /h = 60 l/min = 3661,42 in ³ /min = 2,12 ft ³ /min = 15,85 gpm = 13,198 l gpm
litri al minuto	l/min	1 l/min = 0,001 m ³ /min = 0,06 m ³ /h = 0,0167 l/s = 61,024 in ³ /min = 0,035 ft ³ /min = 0,264 gpm = 0,22 l gpm
cubic inch per minute	in ³ /min	1 in ³ /min = 0,00027 l/s = 0,016 l/min = 0,00058 ft ³ /min = 0,0043 gpm = 0,0036 l gpm
cubic foot per minute	ft ³ /min	1 ft ³ /min = 0,00047 m ³ /s = 0,028 m ³ /min = 1,7 m ³ /h = 0,472 l/s = 28,32 l/min = 1'728 in ³ /min = 7,48 gpm = 6,23 l gpm
gallon per minute	gpm	1 gpm = 0,0038 m ³ /min = 0,227 m ³ /h = 0,063 l/s = 3,785 l/min = 231 in ³ /min = 0,134 ft ³ /min = 0,833 l gpm
imperial gallon per minute	l gpm	1 l gpm = 0,000076 m ³ /s = 0,00454 m ³ /min = 0,273 m ³ /h = 0,076 l/s = 4,55 l/min = 277,42 in ³ /min = 0,16 ft ³ /min = 1,2 gpm



Unità di misura e principali grandezze

Units and main sizes

Tab.24 Velocità

Grandezza	simbolo	conversioni
metri al secondo	m/s	1 m/s = 60 m/min = 3,6 km/h = 39,37 in/s = 2'362,2 in/min = 3,28 ft/s = 196,85 ft/min = 2,237 mi/h = 1,94 kn
kilometri all'ora	km/h	1 km/h = 0,278 m/s = 16,67 m/min = 10,963 in/s = 656,17 in/min = 0,91 ft/s = 54,68 ft/min = 0,62 mi/h = 0,54 kn
metri al minuto	m/min	1 m/min = 0,0167 m/s = 0,06 km/h = 0,66 in/s = 39,37 in/min = 0,0547 ft/s = 3,28 ft/min = 196,85 ft/h = 0,037 mi/h = 0,032 kn
inch per second	in/s	1 in/s = 0,0254 m/s = 1,524 m/min = 0,091 km/h = 60 in/min = 0,083 ft/s = 5 ft/min = 300 ft/h = 0,057 mi/h = 0,049 kn
inch per minute	in/min	1 in/min = 0,0254 m/min = 0,001524 km/h = 0,167 in/s = 0,0014 ft/s = 0,083 ft/min = 5 ft/h
foot per second	ft/s	1 ft/s = 0,305 m/s = 18,288 m/min = 1,097 km/h = 12 in/s = 720 in/min = 60 ft/min = 0,68 mi/h = 0,59 kn
foot per minute	ft/min	1 ft/min = 0,00508 m/s = 0,3048 m/min = 0,0183 km/h = 0,2 in/s = 12 in/min = 0,0167 ft/s = 60 ft/h = 0,011 mi/h = 0,0099 kn
foot per hour	ft/h	1 ft/h = 0,005 m/min = 0,0033 in/s = 0,2 in/min = 0,0167 ft/min
mile per hour	mi/h	1 mi/h = 0,447 m/s = 26,82 m/min = 1,609 km/h = 17,6 in/s = 1'056 in/min = 1,47 ft/s = 88 ft/min = 0,87 kn
nautical mile per hour = nodo	kn	1 kn = 0,51 m/s = 30,89 m/min = 1,85 km/h = 20,27 in/s = 1'216 in/min = 1,69 ft/s = 101,33 ft/min = 1,15 mi/h

Tab.25 Velocità angolare

Grandezza	simbolo	conversioni
radianti al secondo	rad/s	1 rad/s = 60 rad/min = 0,159 giri/s = 9,55 giri/min
radianti al minuto	rad/min	1 rad/min = 0,0167 rad/s = 0,0026 giri/s = 0,159 giri/min
giri al secondo	giri/s	1 giro/s = 60 giri/min = 6,283 rad/s = 376,99 rad/min
giri al minuto	giri/min	1 giro/min = 0,0167 giri/s = 0,1047 rad/s = 6,283 rad/min

Tab.26 Forza

Grandezza	simbolo	conversioni
Newton	N	1 N = 0,102 kgf = 0,0001 t = 0,2248 lbf = 3,597 ozf
kilogrammo forza; kilogrammo peso	kgf; kgp	1 kgf = 9,81 N = 0,001 t = 2,204 lbf = 35,27 ozf
tonnellata peso	t	1 t = 9'806,65 N = 1'000 kgf = 2'204,62 lbf = 35'274 ozf
kilopound	kip	1 kip = 4'448 N = 453,59 kgf = 1'000 lbf = 16'000 ozf
pound force (libbra)	lbf	1 lbf = 4,448 N = 0,454 kgf = 16 ozf
ounce force (oncia)	ozf	1 ozf = 0,278 N = 0,028 kgf = 0,0625 lbf

Tab.27 Potenza		
Grandezza	simbolo	conversioni
kilowatt	kW	1 kW = 1,36 CV = 1,34 hp = 737,56 lbf·ft/s = 4'4253,7 lbf·ft/min = 859,84 kcal/h = 3'412,14 btu/h = 101,97 kgf·m/s
cavallo vapore	CV	1 CV = 0,735 kW = 0,986 hp = 75 kg·m/s = 542,47 lbf·ft/s = 632,41 kcal/h = 2'509,62 btu/h = 75 kgf·m/s
kilogrammo forza per metri al secondo	kgf·m/s	1 kgf·m/s = 0,01 kW = 0,013 CV = 0,013 hp = 7,23 lbf·ft/s = 433,98 lbf·ft/min = 8,43 kcal/h = 33,46 btu/h
kilocaloria all'ora	kcal/h	1 kcal/h = 0,0012 kW = 0,0016 CV = 0,00156 hp = 0,8578 lbf·ft/s = 51,47 lbf·ft/min = 3,97 btu/h = 0,12 kgf·m/s
horsepower	HP	1 HP = 1,014 CV = 0,746 kW = 550 lbf·ft/s = 33000 lbf·ft/min = 641,19 kcal/h = 2'544,43 btu/h = 76,04 kgf·m/s
foot pound force per second	lbf·ft/s	1 lbf·ft/s = 0,0013 kW = 0,0018 CV = 0,0018 hp = 60 lbf·ft/min = 1,166 kcal/h = 4,63 btu/h = 0,138 kgf·m/s
foot pound force per minute	lbf·ft/min	1 lbf·ft/min = 0,000023 kW = 0,0167 lbf·ft/s = 0,019 kcal/h = 0,077 btu/h = 0,0023 kgf·m/s
british thermal unit per hour	BTU/h	1 btu/h = 0,00029 kW = 0,216 lbf·ft/s = 12,97 lbf·ft/min = 0,25 kcal/h = 0,030 kgf·m/s

Tab.28 Lavoro - Energia - Momento - Coppia - Calore		
Grandezza	simbolo	conversioni
joule	J	1 J = 1N·m = 0,102 kgf·m = 0,00024 kcal = 8,85 lbf·in = 0,74 lbf·ft = 0,00095 BTU
kilogrammo forza per metro	kgf·m	1 kgf·m = 9,807 J = 0,0023 kcal = 86,80 lbf·in = 7,233 lbf·ft = 0,0093 BTU
cavallo vapore per ora	CV·h	1 CV·h = 270'000 kgf·m = 0,736 kW·h = 632,41 kcal = 2'509 BTU
kilocaloria	kcal	1 kcal = 4,1868 kJ = 426,93 kgf·m = 0,0016 CV·h = 0,0012 kW·h = 37'056,3 lbf·in = 3'088 lbf·ft = 3,97 BTU
kilowatt per ora	kW·h	1 kW·h = 3'600 kJ = 1,36 CV·h = 859,8 kcal = 3'412,14 BTU
pound force inch	lbf·in	1 lbf·in = 0,113 J = 0,0115 kgf·m = 0,083 lbf·ft = 0,0001 BTU
pound force foot	lbf·ft	1 lbf·ft = 1,356 J = 0,138 kgf·m = 0,324 cal = 12 lbf·in = 0,0013 BTU
horse power hour	HP·h	1 HPh = 2,684 MJ = 641,19 kcal = 1,014 CV·h = 0,746 kW·h = 1'980'000 lbf·ft = 2'544,43 BTU
british thermal unit	BTU	1 BTU = 1'055,056 J = 107,58 kgf·m = 0,0004 CV·h = 0,252 kcal = 0,00029 kWh = 9'338,03 lbf·in = 778,17 lbf·ft



Unità di misura e principali grandezze

Units and main sizes

Tab.29 Densità		
Grandezza	simbolo	conversioni
kilogrammo su metro cubo	kg/m ³	1 kg/m ³ = 0,001 kg/dm ³ = 0,001 t/m ³ = 0,001 g/cm ³ = 0,062 lb/ft ³ = 0,00075 tn/yd ³ = 0,00084 s tn/yd ³ = 0,133 oz/gal
kilogrammo su decimetro cubo	kg/dm ³	1 kg/dm ³ = 1'000 kg/m ³ = 0,001 g/cm ³ = 1 t/m ³ = 1 g/cm ³ = 62,42 lb/ft ³ = 0,036 lb/in ³ = 133,53 oz/gal
tonnellata su metro cubo	t/m ³	1 t/m ³ = 1'000 kg/m ³ = 1 kg/dm ³ = 0,001 kg/cm ³ = 1 g/cm ³ = 62,43 lb/ft ³ = 0,036 lb/in ³ = 0,752 tn/yd ³ = 0,843 s tn/yd ³ = 133,53 oz/gal
pound per cubic foot	lb/ft ³	1 lb/ft ³ = 16,018 kg/m ³ = 0,016 kg/dm ³ = 0,016 t/m ³ = 0,016 g/cm ³ = 0,00058 lb/in ³ = 0,012 tn/yd ³ = 0,0135 s tn/yd ³ = 2,14 oz/gal
pound per cubic inch	lb/in ³	1 lb/in ³ = 27,68 kg/dm ³ = 0,02768 kg/cm ³ = 27,68 t/m ³ = 27,68 g/cm ³ = 1'728 lb/ft ³ = 20,83 tn/yd ³ = 23,33 s tn/yd ³ = 3'696 oz/gal
ounce per gallon	oz/gal	1 oz/gal = 7,489 kg/m ³ = 0,00749 kg/dm ³ = 0,00749 t/m ³ = 0,00749 g/cm ³ = 0,467 lb/ft ³ = 0,00027 lb/in ³ = 0,00563 tn/yd ³ = 0,0063 oz/gal

Tab.30 Temperatura		
Grandezza	simbolo	conversioni
Kelvin	K	K = °C + 273,15 K = 1,8 · °R K = [5/9 · °F] + (459,67/1,8)
grado Celsius	°C	°C = (°F - 32) · 5/9 °C = K - 273,15 °C = (5/9) · °F - (32/1,8)
grado Fahrenheit	°F	°F = 9/5 · °C + 32 °F = °R - 459,67 °F = (9/5) · K - 459,67
grado Rankine	°R	°R = (5/9) K °R = 491,67 + (9/5) · °C °R = 459,67 + °F

Tab.31 Accellerazione		
Grandezza	simbolo	conversioni
metro al secondo quadrato	m/s ²	1 m/s ² = 100 cm/s ² = 0,001 km/s ² = 3,28 ft/s ² = 39,37 in/s ² = 0,00062 mi/s ²
centimetro al secondo quadrato	cm/s ²	1 cm/s ² = 0,01 m/s ² = 0,00001 km/s ² = 0,0328 ft/s ² = 0,394 in/s ²
kilometro al secondo quadrato	km/s ²	1 km/s ² = 1'000 m/s ² = 100'000 cm/s ² = 3'280,84 ft/s ² = 39'370,08 in/s ² = 0,621 mi/s ²
foot per square second	ft/s ²	1 ft/s ² = 0,3048 m/s ² = 30,48 cm/s ² = 12 in/s ²
inch per square second	in/s ²	1 in/s ² = 0,0254 m/s ² = 2,54 cm/s ² = 0,083 ft/s ²
mile per square second	mi/s ²	1 mi/s ² = 1'609,34 m/s ² = 1,609 km/s ² = 5'280 ft/s ² = 63'360 in/s ²

Condizioni di immagazzinamento

Storage conditions

Le condizioni di immagazzinamento sono fondamentali per prodotti realizzati in elastomeri e termoplastici, molto sensibili alle condizioni ambientali. Un immagazzinamento inadeguato può causare significative variazioni nelle proprietà fisiche e meccaniche e provocare indurimenti, rammollimenti, crepe, screpolature o altre degradazioni dovute a ossigeno, ozono, luce, calore e/o umidità che possono compromettere l'utilizzo di questi polimeri.

Per stoccare correttamente gli elastomeri termoplastici ed evitare il loro danneggiamento andrebbero rispettate le seguenti raccomandazioni:

Temperatura

La temperatura di immagazzinamento non dovrebbe superare i 50°C. Temperature inferiori non costituiscono invece un problema.

Luce

Proteggere dalla luce diretta del sole o da altre fonti di luce artificiale se molto potenti. In caso utilizzare confezioni con filtri UV.

Umidità

L'umidità ideale è di circa 65% in ambiente privo di correnti dirette.

Ossigeno e ozono

I prodotti in materiali elastomeri devono essere protetti dalle correnti d'aria. Dato che l'ozono è particolarmente dannoso per la gomma, i locali di stoccaggio devono essere privi di attrezzature che possano generare scintille o scariche elettriche. Si suggerisce il confezionamento in opportuni contenitori.

The storage conditions are a very important issue when it comes to products in elastomeric or thermoplastic materials, as they are environmentally sensitive. If not suitably stored these polymers experience significant changes in their physical or mechanical properties, that can even impair the item usage. Hardening, softening, cracks, or other types of damage may occur, due to the exposure to oxygen, ozone, light, heat and/or humidity.

Below are provided recommendations concerning the most suitable storage conditions for our products, that should be complied with to prevent the products damaging.

Temperature

The storage temperature should not exceed 50°C; Lower temperatures do not impair thermoplastic, elastomeric materials. We recommend to warm up the items to a temperature of 30° before mounting.

Light

Do not expose to direct sunlight or other artificial light sources, if very powerful. If this condition cannot be avoided, use packages supplied with UV filters;

Humidity

The ideal humidity level is about 65% in an environment with no direct currents;

Oxygen and ozone

Products in elastomeric material should be protected from drafts. Ozone is especially detrimental for rubber, in particular in the areas where the products are to be stored. For this reason no equipment that could produce sparks or electric discharges should be placed in those areas. We recommend packaging in suitable boxes.



Deformazione

I prodotti realizzati in termoplastici elastomeri dovrebbero sempre essere stoccati in spazi adeguati alle loro dimensioni evitando schiacciamenti, deformazioni, distorsioni e stiramenti. Si consiglia pertanto di posizionarli in appositi scaffali o piani e di non appenderli o schiacciarli.

Contatto con liquidi

Durante lo stoccaggio evitare il contatto con solventi, acidi, basi, oli e grassi.

Contatto con metalli

Alcuni metalli come il manganese in ferro, il rame o le sue leghe possono essere particolarmente nocivi per la gomma. Pertanto si suggerisce di separare questi materiali con carta, polietilene o normale busta di cellophane.

Rotazione di magazzino

Si consiglia di applicare una corretta rotazione delle scorte di magazzino onde evitare lunghi periodi di stoccaggio.

Pulizia

In caso si renda necessario, lavare con acqua e sapone e asciugare a temperatura ambiente prima dell'uso. Solventi organici come tricloroetilene, tetracloruro di carbonio e petrolio risultano molto aggressivi e se ne sconsiglia l'uso.

Durata stoccaggio

La tabella sottostante riporta la durata dei prodotti realizzati nei materiali più comuni e stoccati in modo corretto. Lo scorretto immagazzinamento riduce la durata.

Deformation

Products in thermoplastic elastomers should be stored in areas suitable for their dimensions, thus avoiding squeezing, distortion or stretching. We recommend to place them on suitable shelves or resting surfaces. We do not recommend hanging or pressing them. Avoid stretching and deformations.

Contact with fluids

During storage, avoid contact with solvents, oils or greases.

Contact with metals

Some metal as manganese, iron and copper or its alloys may be detrimental for rubber. Therefore, we recommend to keep this materials separated using paper, polyethylene or simple cellophane bags.

Inventory turnover

We recommend applying a correct stock rotation, to avoid long storage periods of the items.

Cleaning

If necessary, wash with water and soap and dry at room temperature before use. Organic solvents as trichloroethylene, carbon tetrachloride and petrol are aggressive and not recommended.

Storage period

The table below shows the life of products made out of the most common materials in ideal storage conditions.

Unsuitable storage conditions result in the reduction of the product life.

Una volta prelevati i prodotti da magazzino e prima di procedere con il loro utilizzo si consiglia di verificare la durata di stoccaggio e l'assenza dei principali difetti da immagazzinamento inadeguato come:

- difetti meccanici
- distorsioni permanenti
- crepe o screpolature superficiali
- incollaggio o indurimento/rammollimento superficiale.

I pezzi con sezione inferiore a 1 mm presentano maggiori criticità in termini di invecchiamento.

After collecting the products from the warehouse and before using them, we recommend to check the storage period and make sure no major damages have occurred, e.g.:

- *mechanical faults*
- *permanent distortions*
- *surface cracks*
- *gluing or surface hardening/softening.*

Thinnest items (section less than 1 mm) are more critical when it comes to ageing.

Tab. 32 - profili superficie/ surface profile

Base Polymer (Iso Designation)	Primary Storage period (Years)	Extension of storage period after re- inspection (Years)
<ul style="list-style-type: none"> • NITRILE (NBR) 	7	3
<ul style="list-style-type: none"> • SILICON (UHQ) • VITON (FKM) • ETILENE PROPILENE (EPDM) • POLYURETHANE (TPU) 	10	5
<ul style="list-style-type: none"> • ACETAL (POM) • POLYAMIDE (PA) • TEFLON (PTFE) • TERMOPLASTIC ELASTOMER (TPE) 	UNLIMITED	

Quanto riportato è necessario a preservare la qualità del prodotto; tuttavia Artic Seals non si assume alcuna responsabilità per danni e alterazioni addebitabili a ulteriori cause non previste da tali raccomandazioni.

The recommendations above are to be complied with to preserve the product quality. Nevertheless Artic Seals shall not assume no responsibility whatsoever for damages or alterations due to other causes, that are not covered by these recommendations.



Qualità e certificazioni

Quality and certifications

Artic Seals realizza i propri prodotti tramite un Sistema di Qualità Totale Certificato. Obiettivi e piani per la qualità, sviluppati con il quality management del gruppo GAPI, si basano su fabbisogni e aspettative del mercato e sul soddisfacimento delle esigenze del cliente tramite continui miglioramenti di progetto, prodotto e servizio.

La qualità dei prodotti costituisce l'obiettivo principale perseguito nel corso degli anni. Introducendo attrezzature sempre più sofisticate e legate a innovazione e automazione (robot antropomorfi per lo stampaggio, trimming e packaging automatici, impianti di visione artificiale computerizzata e automatizzata per il controllo al 100% dei prodotti ove richiesto) si è voluto ottenere costanza, stabilità e ripetibilità di tutti i processi. Ogni fase risulta oggi integrata all'interno dell'ERP aziendale per garantire un immediato controllo sui processi e sulle relative performance.

In questa stessa ottica, e per garantire la totale conformità dei prodotti ai requisiti specificati, effettuiamo accurati controlli in fase di accettazione delle materie prime, durante il processo e in fase di collaudo finale.

Divenuta lead center per il settore idraulico e pneumatico, Artic Seals sfrutta le sinergie tra le aziende del gruppo GAPI per condividere tecnologie e competenze sviluppate in specifici settori; per creare prodotti tramite l'ausilio di materiali e processi interni al gruppo e accedere a laboratori di analisi dove testare le principali proprietà chimiche, fisiche e meccaniche dei materiali trattati.

Conformemente agli standard e alle certificazioni di gruppo, Artic Seals esegue un attento controllo in fase di accettazione delle materie prime, durante il processo e in fase di collaudo finale per garantire la totale conformità dei prodotti ai requisiti specificati. I certificati di collaudo e gli attestati di conformità sulla merce in consegna sono rilasciati dall'ufficio tecnico.

Artic Seals manufactures its products in compliance with a Certified Global Quality System, that provides quality targets and programmes developed together with the Gapi Group Quality management and based on the market needs and expectations, striving to meet the customers' requirements by constantly improving designs, products and services.

The product quality is the main target we invested in over the years, introducing increasingly sophisticated equipment pursuing innovation and automation, to achieve consistency, stability and repeatability for all our processes: anthropomorphic robots in moulding departments, completely automatic trimming, automatic packaging and computer vision, totally automatic systems to check the product 100%, where requested. Each phase is integrated into the company's ERP system to provide immediate monitoring of processes and related performances. Artic Seals carries out a careful inspection of incoming raw materials, as well as during the process and the final testing phase, to guarantee total conformance of the products with the specifications.

The synergies among the group's companies play a vital role in terms of access to technologies, skills and know-how especially developed for specific areas of competence and shared among the subsidiaries. In this context Artic Seals plays a crucial role as Hydraulic and Pneumatic Lead Center and develops its products using the group own materials and processes.

The group provides also a key service related to material science, offering the subsidiaries access to two analysis labs to test the main chemical, physical and mechanical properties of the materials processed.

To receive testing and/or compliance certificates for the supply goods, please turn to our offices and possibly specify the reference standard.

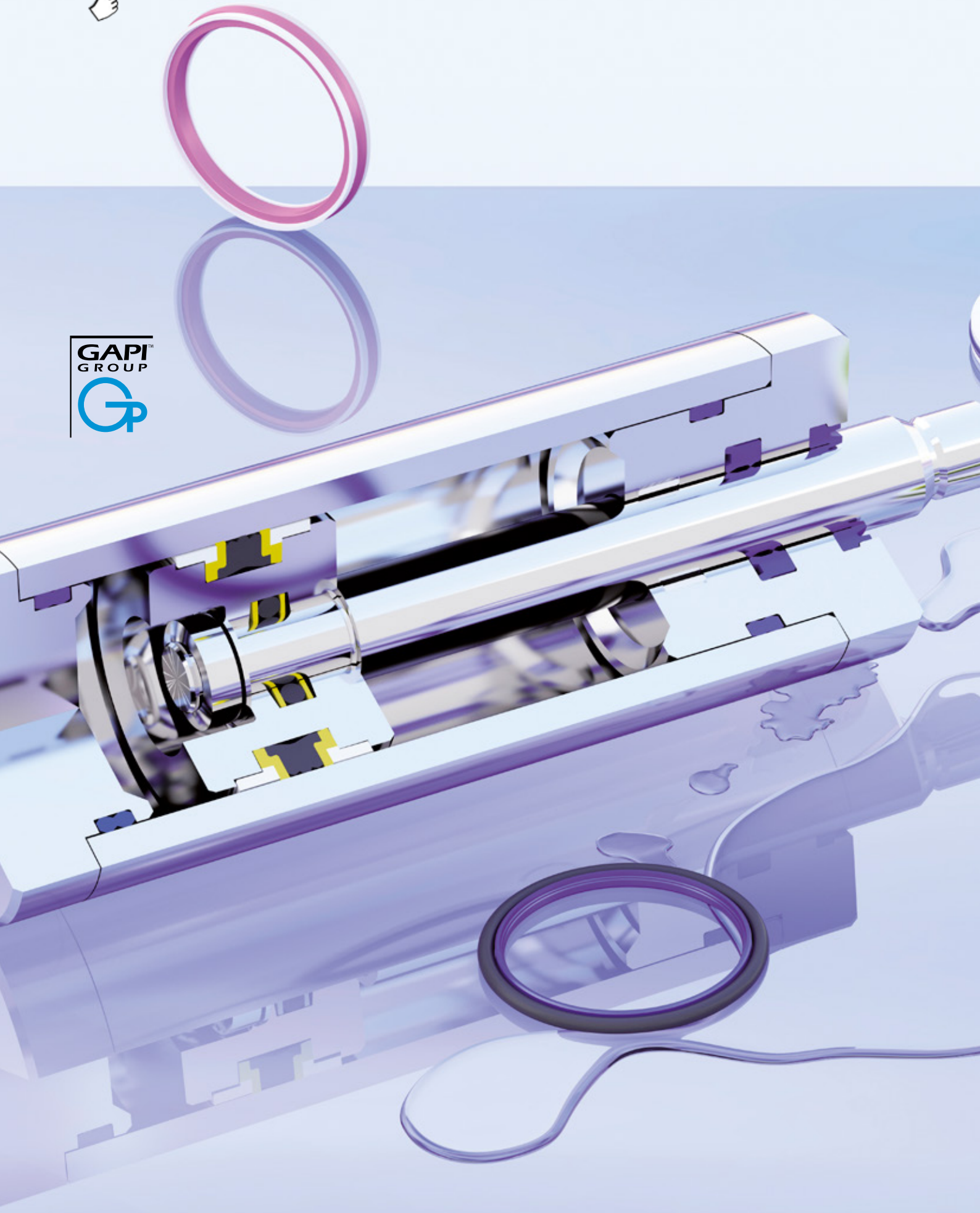





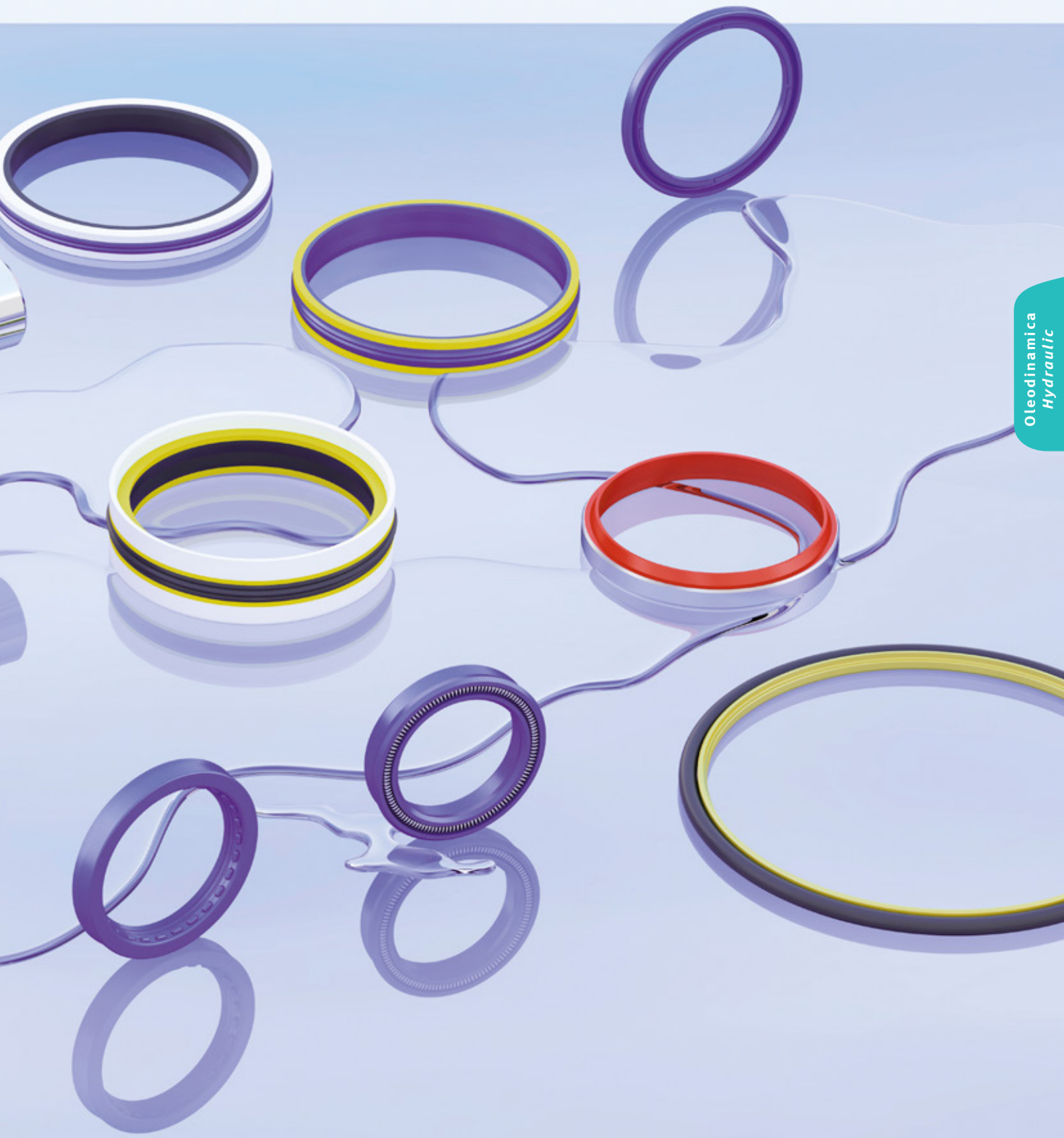















Sistemi di tenuta per oleodinamica *Hydraulic sealing systems*



Oleodinamica
Hydraulic

Profili oleodinamica: tenute stelo Hydraulic profiles: rod seals

GUARNIZIONI STELO / ROD SEALS										
Condizioni massime non simultanee / Maximum conditions (not combined)										
Profilo Profile	Ns Rif. Our Ref.	Temperatura Temperature C°	Pressione Pressure Bar	Velocità Speed m/s	Materiale Material	TPU POM / PA PTFE Bronze	NBR	TPE Resina PTFE Carbo.	Sezione Section	Pagina Page
	RSA	-35 +100	< 400	< 0,5	TPU	●			Idraulica Hydraulic	66
	RLF®	-35 +100	< 400	< 0,5	TPU	●			Idraulica Hydraulic	70
	RSB	-35 +100	< 400	< 0,5	TPU	●			Idraulica Hydraulic	74
	RSB2	-35 +100	< 500	< 0,5	TPU POM	● ○			Idraulica Hydraulic	80
	BLF®	-35 +100	< 400	< 0,5	TPU	●			Idraulica Hydraulic	82
	RSC	-35 +100	< 400	< 0,5	TPU	●			Idraulica Hydraulic	86
	RSD	-35 +100	< 400	< 0,5	TPU	●			Idraulica Hydraulic	90
	RPO	-35 +100	< 400	< 0,5	TPU	●			Idraulica Hydraulic	94
	AS®	-50 +135	< 400	< 0,5	TPU Technopolymer	●			Idraulica Hydraulic	98
	RSBI/RPOI	-35 +100	< 400	< 0,5	TPU	●	●		Idraulica Hydraulic	100
	RAA	-30 +135	< 600	< 1	POM	○			Idraulica Hydraulic	104
	TSS/P	-35 +100	< 600	5	TPU NBR	●	●		Idraulica Hydraulic	106
	TSS	-30 +120	< 600	15	PTFE bronzo/ bronze NBR	●	●		Idraulica Hydraulic	110
	RSO	-35 +100	< 400	< 0,5	TPU NBR	●	●		Idraulica Hydraulic	112
	RBR	-35 +100	< 400	< 0,8	TPU TPE	●		●	Idraulica Hydraulic	114
	RSS	-35 +100	< 400	< 0,5	TPU NBR	●	●		Idraulica Hydraulic	116
	RPS	-35 +100	< 400	< 0,5	TPU	●			Idraulica Hydraulic	118

GUARNIZIONI ROTAZIONE / ROTARY SEALS										
	GDR	-35 +100	< 400	< 0,5	TPU	●			Idraulica Hydraulic	176



Profili oleodinamica: tenute pistone











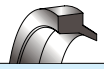



Hydraulic profiles: piston seals

GUARNIZIONI PISTONE / PISTON SEALS									
Condizioni massime non simultanee / Maximum conditions (not combined)									
Profilo Profile	Ns Rif. Our Ref.	Temperatura Temperature C°	Pressione Pressure Bar	Velocità Speed m/s	Materiale Material	TPU POM / PA PTFE Bronze NBR	TPE Resina PTFE Carbo. PTFE	Sezione Section	Pagina Page
	PSA	-35 +100	< 400	< 0,5	TPU	●		Idraulica Hydraulic	122
	PAE	-35 +100	< 500	< 0,5	TPU POM	● ○		Idraulica Hydraulic	126
	PSH+RR	-35 +100	< 400	< 0,5	TPU POM	● ○		Idraulica Hydraulic	128
	PSO	-30 +100	< 250 materiali standard standard materials < 400 materiali alternativi alternative materials	< 0,5	TPU NBR	● ●		Idraulica Hydraulic	130
	PSQ	-30 +100	< 250 materiali standard standard materials < 400 materiali alternativi alternative materials	< 0,5	TPU NBR	● ●		Idraulica Hydraulic	134
	PSN	-30 +110	< 250	< 4	Technopolymer NBR		○	Hydraulic / Pneumatic	136
	TPD	-30 +120	< 600	15	PTFE bronzo/bronze NBR	● ●		Idraulica Hydraulic	138
	PSI	-30 +100	< 300	< 0,5	TPU NBR	● ●		Idraulica Hydraulic	140
	PSZ	-30 +110	< 600	1	PA66 NBR	● ●		Idraulica Hydraulic	142
	PHP	-30 +100	< 600	< 1,5	TPU POM NBR	● ○ ●		Idraulica Hydraulic	144
	KDSA	-30 +100	< 400	< 0,5	POM NBR TPE	○ ● ●		Idraulica Hydraulic	146
	KDSB	-30 +100	< 400	< 0,5	POM NBR TPE	○ ● ●		Idraulica Hydraulic	148
	KDSB/AE	-30 +100	< 400	< 0,5	POM NBR TPE	○ ● ●		Idraulica Hydraulic	152
	KDSP	-30 +100	< 300	< 0,5	TPU POM	● ○		Idraulica Hydraulic	154
	KDAE	-30 +100	< 400	< 0,5	TPU TPE	● ●	●	Idraulica Hydraulic	156

Profili oleodinamica: guide e raschiatori

Hydraulic profiles: wears and wipers

ANELLI DI GUIDA / WEAR RINGS									
(sezione tecnica guide pag. 158/ wear rings technical section pag. 158)									
Condizioni massime non simultanee / Maximum conditions (not combined)									
Profilo Profile	Ns Rif. Our Ref.	Temperatura Temperature C°	Pressione Pressure Bar	Velocità Speed m/s	Materiale Material	TPU POM / PA PTFE Bronze NBR TPE Resina PTFE Carbo. PTFE		Sezione Section	Pagina Page
	HIS HES	-40 +115	-	< 0,8	POM fibre di vetro glass fibres	○		Idraulica Hydraulic	166/166
	NG	-40 +200	-	15	PTFE bronzo/ bronze	●		Idraulica Hydraulic	170
	HPW	-50 +150	-	< 1	Resina Fenolica		●	Idraulica Hydraulic	172
	HEN	-40 +115	-	< 0,8	POM fibre di vetro glass fibres	○		Idraulica Hydraulic	174

RASCHIATORI / WIPERS									
Condizioni massime non simultanee / Maximum conditions (not combined)									
Profilo Profile	Ns Rif. Our Ref.	Temperatura Temperature C°	Pressione Pressure Bar	Velocità Speed m/s	Materiale Material	TPU POM / PA PTFE Bronze NBR TPE Resina PTFE Carbo. PTFE		Sezione Section	Pagina Page
	WSL	-35 +100	-	< 1	TPU	●		Idraulica Hydraulic	178
	RO6	-30 +100	-	< 4	NBR		●	Idraulica Hydraulic	182
	WSG	-35 +100	-	< 1	TPU STEEL	●		Idraulica Hydraulic	186
	IWP	-35 +100	-	< 0,8	TPU STEEL	●		Idraulica Hydraulic	188
	DWP	-35 +100	-	< 0,8	TPU STEEL	●		Idraulica Hydraulic	190
	Ro9	-30 +100	-	< 1	NBR STEEL		●	Idraulica Hydraulic	192
	WWS	-35 +100	-	< 1	TPU	●		Idraulica Hydraulic	194
	WWN	-35 +100	-	< 1	TPU	●		Idraulica Hydraulic	196
	ROB	-30 +100	-	< 4	NBR		●	Idraulica Hydraulic	198
	WAT	-35 +100	-	< 1	TPU	●		Idraulica Hydraulic	202
	TRD	-30 +120	-	< 15	PTFE bronzo/ bronze NBR		● ●	Idraulica Hydraulic	204
	WED	-35 +100	< 20	< 1	TPU	●		Idraulica Hydraulic	206
	WDA	-35 +100	< 50	< 1	TPU	●		Idraulica Hydraulic	210
	WIP	-40 +90	< 20	< 1	TPU	●		Idraulica Hydraulic	212
	WNM	-35 +100	< 20	< 1	PA Filled	●		Idraulica Hydraulic	214
	WEL	-35 +100	-	< 1	TPU	●		Idraulica Hydraulic	216



Schema cilindro idraulico A

Hydraulic cylinder sketch A

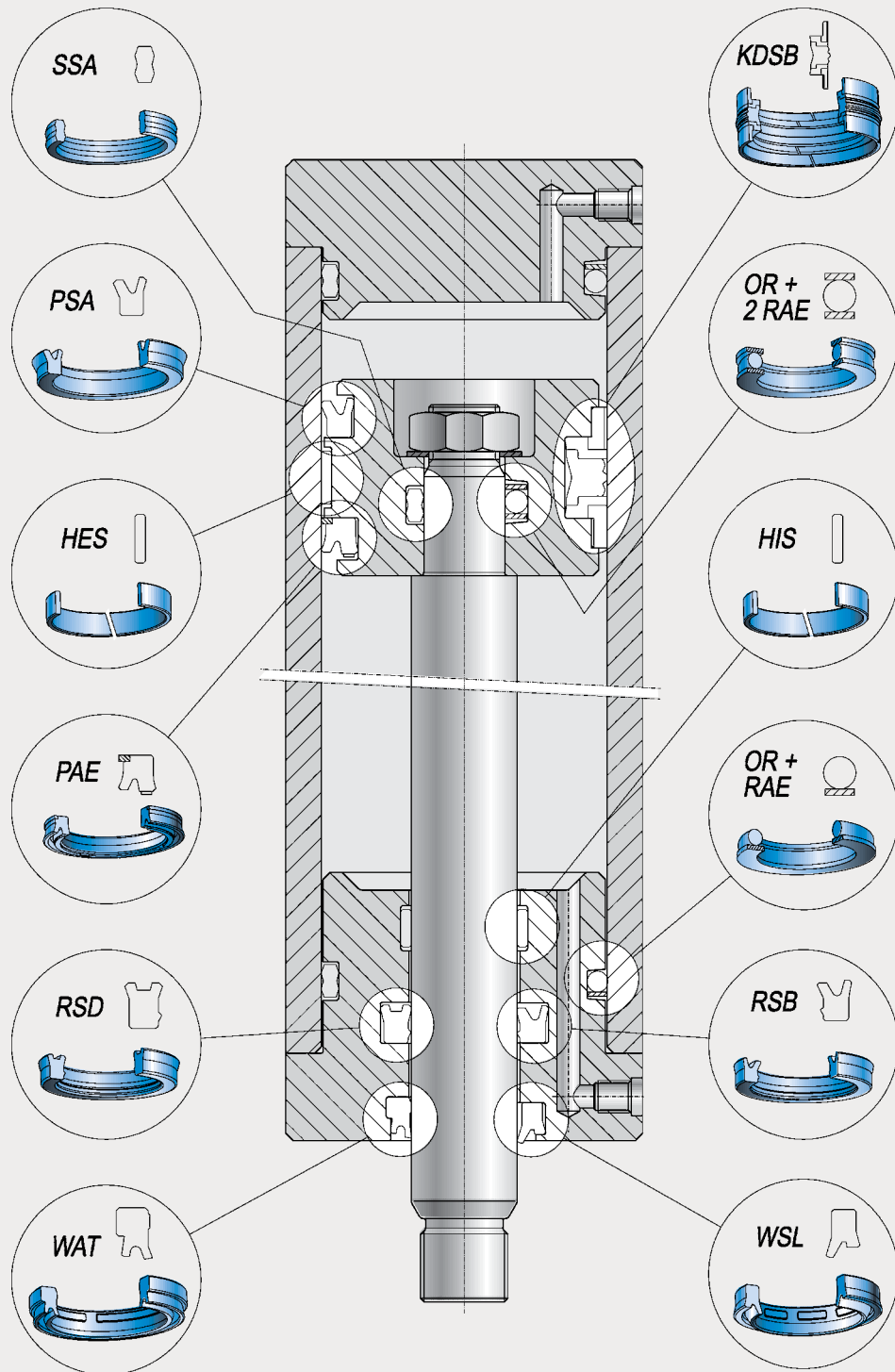

Oleodinamica
Hydraulic

Schema cilindro idraulico B Hydraulic cylinder sketch B

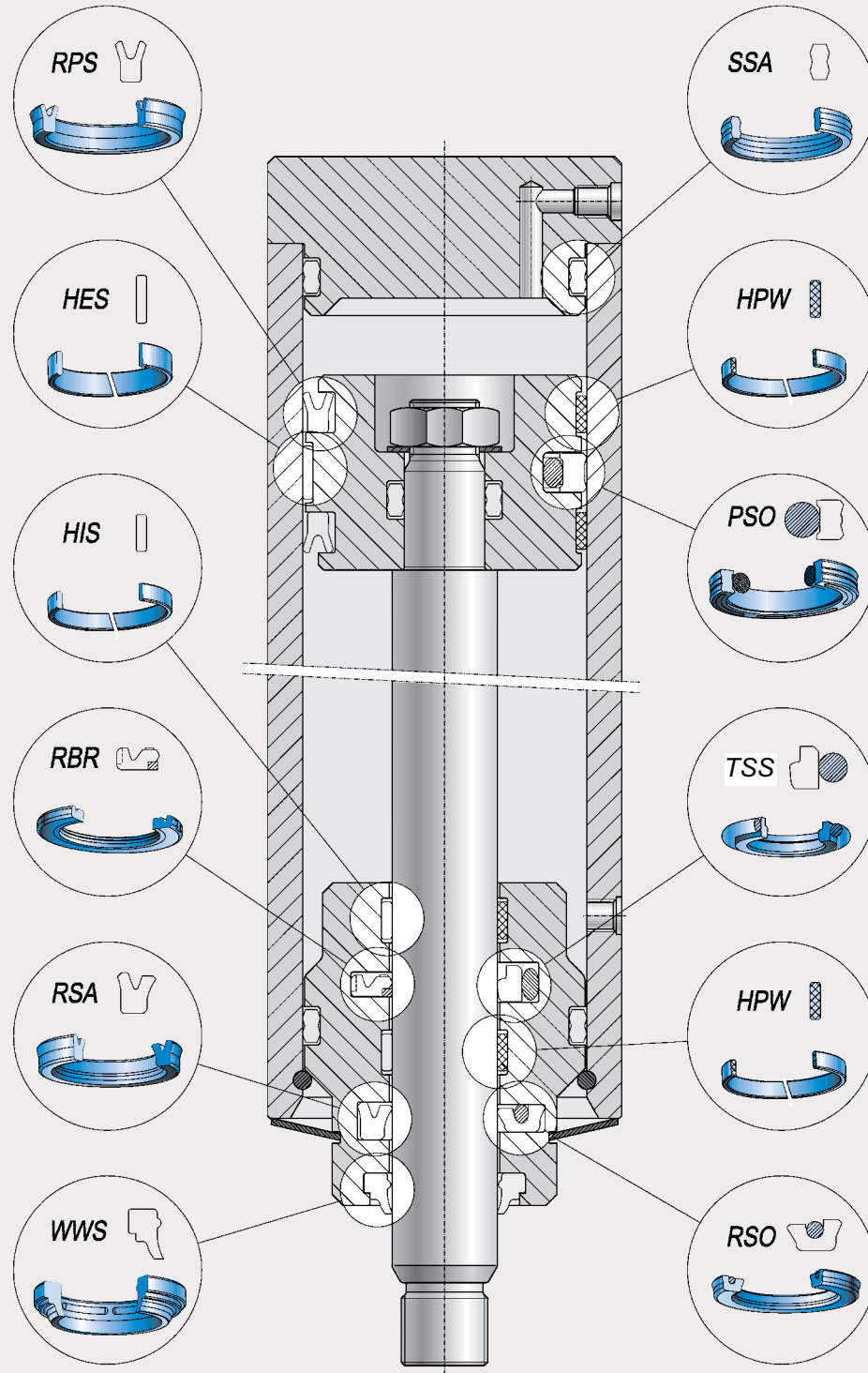



Schema cilindro idraulico C

Hydraulic cylinder sketch C

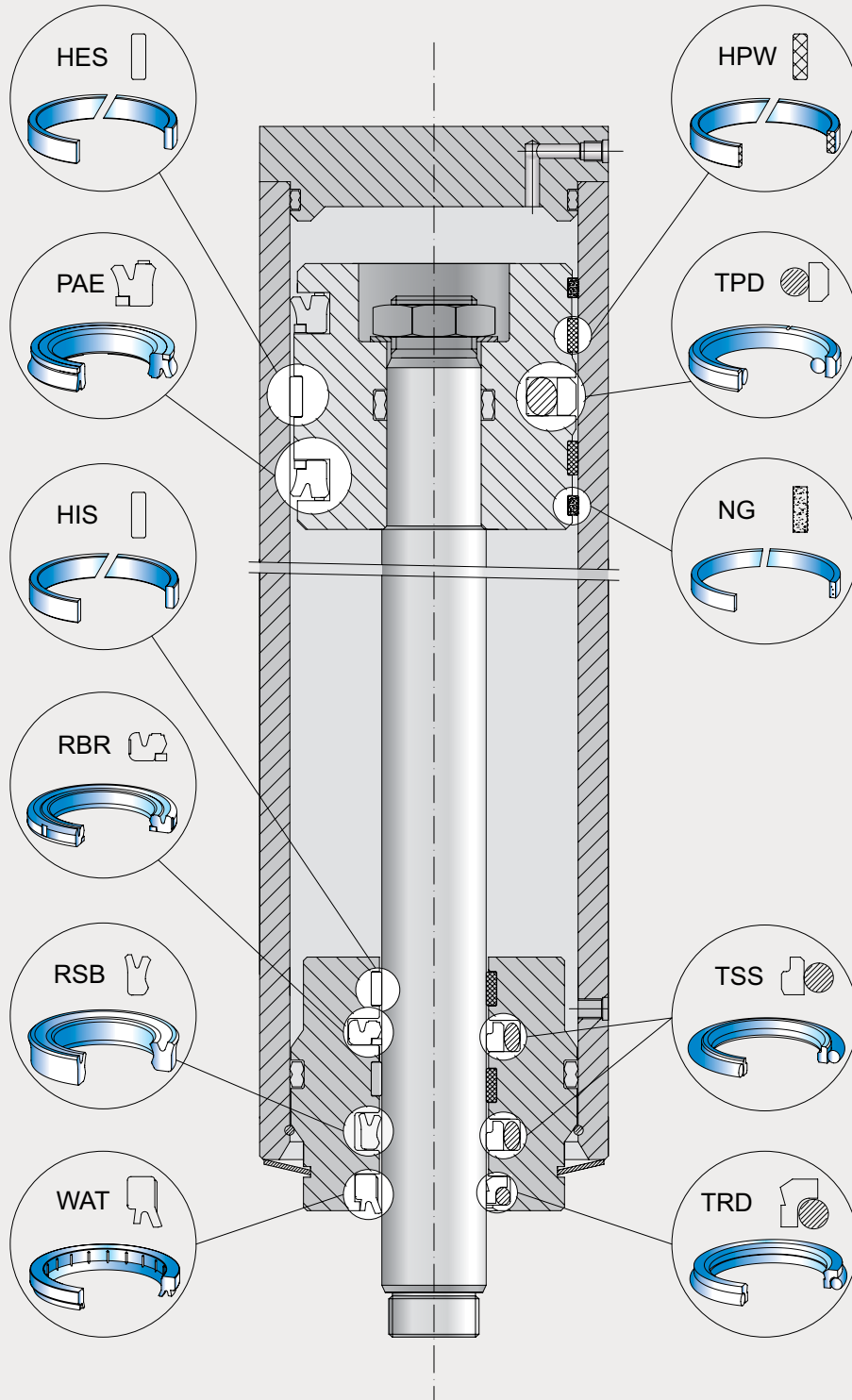

Oleodinamica
Hydraulic

Schema cilindro idraulico D Hydraulic cylinder sketch D

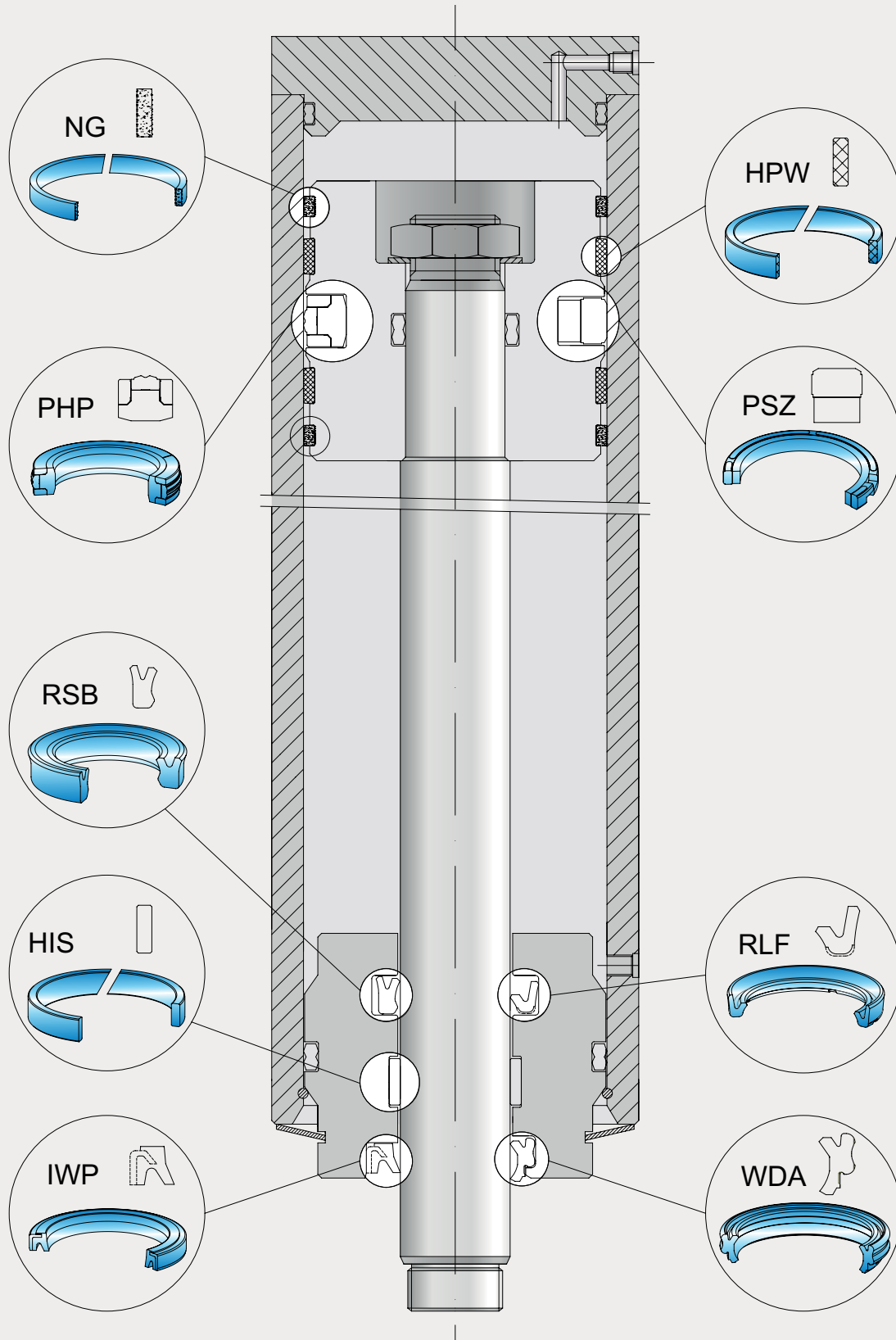



Montaggio Assembling

Avvertenze e precauzioni di montaggio nei sistemi Oleodinamici

Durante il montaggio, per un ottimo funzionamento delle guarnizioni occorre evitare tagli o deformazioni permanenti. Fondamentale anche il rispetto delle norme internazionali ISO per quanto riguarda le dimensioni degli alloggiamenti e le tolleranze.

Assembling instructions

For a correct sealing functioning it's necessary to avoid cuts or permanent deformations during the assembling process. It's also recommended to follow the ISO norms concerning housings and tolerances. Regarding the surfaces finish, take a look at the following sketches 18 and 19 indicating the values to be respected.

A further polishing operation is usually suggested before mounting, since the only grinding operation isn't recommended.

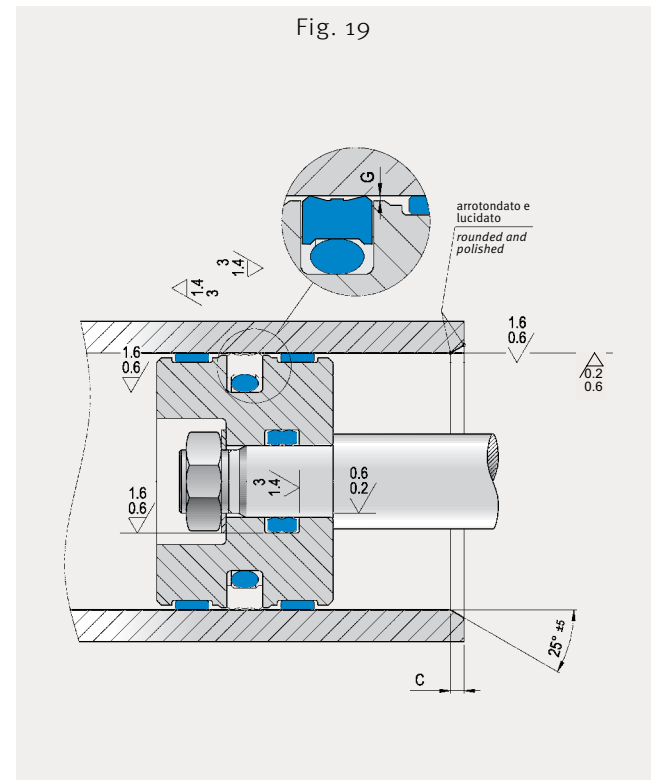
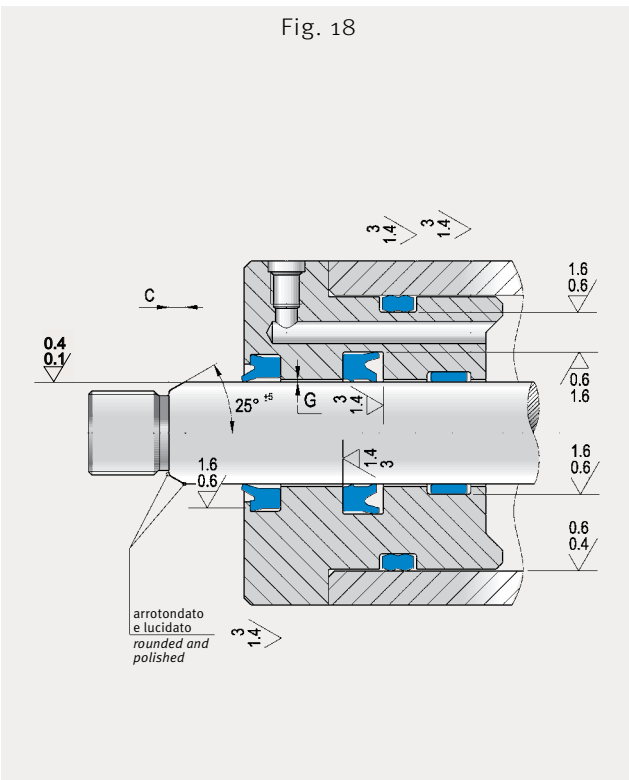

Montaggio tenuta stelo - PTFE

Le guarnizioni PTFE necessitano di precauzioni estremamente rigorose, maggiori che per tutte le altre tipologie di tenuta. È fondamentale eliminare gli spigoli vivi e le bave nelle sedi.

Il montaggio delle guarnizioni per stelo segue normalmente questa sequenza:

- installare o-ring nella sede (fig. 20)
- deformare l'anello in PTFE (fig. 21) senza creare piegature ad angolo vivo
- inserire l'anello nella sede cercando di ridargli la formazione iniziale (fig. 22)
- calibrare con utensile conico in materiale plastico.

Fig. 20 - Pic.20

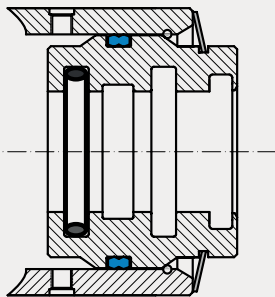

Fig. 21 - Pic.21

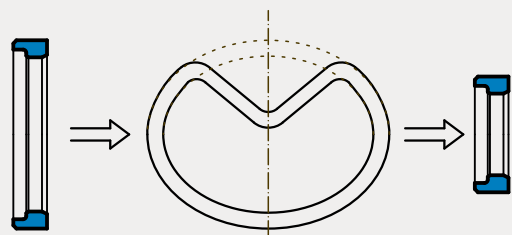

Fig. 22 - Pic.22

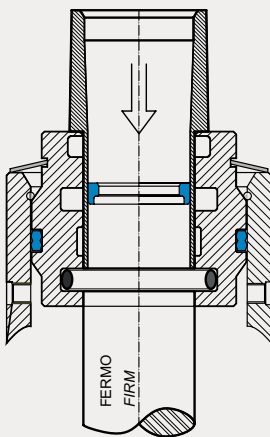
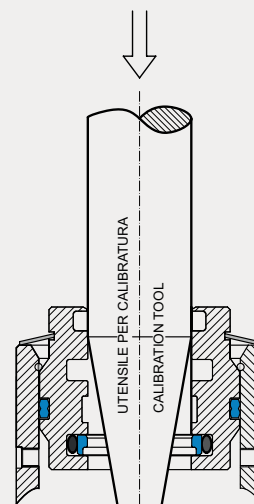

Fig. 23 - Pic.23



Assembling rod seal - PTFE

PTFE seals require careful assembling operations in comparison to other types of seals. It is necessary to remove flashes and/or cutting edges in the grooves.

The rod seal is usually assembled in the following sequence:

- fit the O-Ring into the groove (Pic.20)
- twist the PTFE ring (as shown in Pic.21), without causing any open edge curl
- insert the ring into the groove restoring the original shape (Pic.22)
- calibrate with a plastic conical tool (Pic.23).



Montaggio tenuta pistone - PTFE

Analogamente a quanto indicato in precedenza, il montaggio delle guarnizioni per pistone segue normalmente questa sequenza:

- installare l'o-ring nella sede
- spingere dilatando l'anello in PTFE, con l'ausilio di un mandrino e una bussola a espansione (fig. 24)
- calibrare con una bussola opportunamente dimensionata (fig. 25).

Si consiglia di riscaldare la guarnizione fino a 50°C.

Assembling piston seal - PTFE

As previously indicated, the piston seal is usually assembled in the following sequence:

- fit the o-ring into the groove
- twist the PTFE ring using a mandrel and an expansion bush (Pic.24)
- calibrate with a bush with right dimension (Pic.25).

Warming the seal up to 50°C is recommended.

Fig. 24 - Pic.24

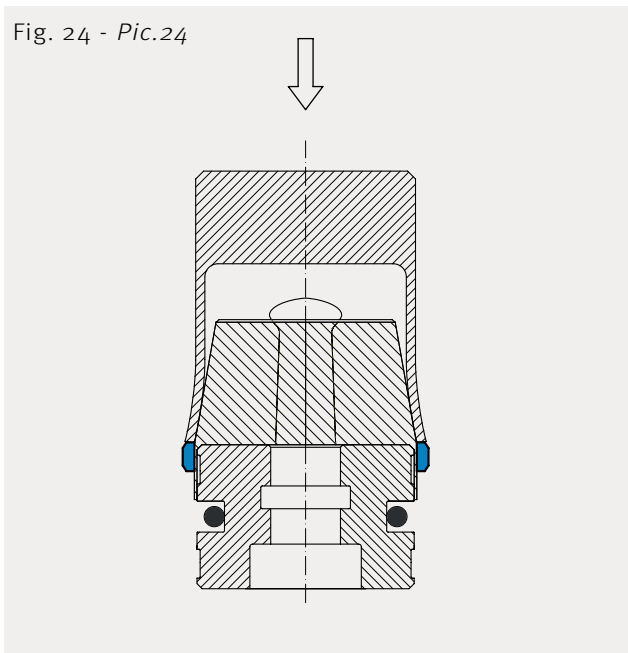
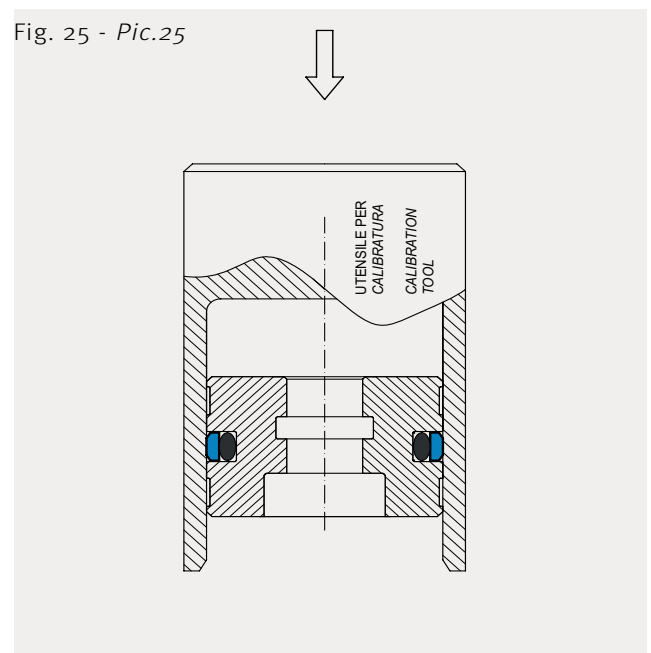
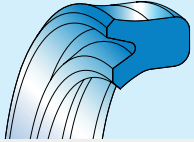

Fig. 25 - Pic.25





RSA

TENUTA STELO TIPO RSA

Descrizione

La guarnizione tipo RSA, progettata con labbro dinamico più corto rispetto a quello statico, ha impieghi dove i disallineamenti dello stelo sono elevati e dove le pressioni possono raggiungere valori elevati.

Dati tecnici

Pressione: < 400 bar a temperatura di 60° C
 Velocità: < 0.5 m/s
 Temperatura: da - 35° C a + 100° C con punte fino a 110° C
 Fluidi: fluidi idraulici a base minerale minerale (tabella 3 p. 14)

Materiale

Il materiale proposto è il poliuretano tipo Co ad alto modulo elastico, basso compression-set ed elevata resistenza all'abrasione.

Ha un durezza di 93 Shore A ± 2.

Codice materiale: CO

Montaggio

Per evitare che la guarnizione si danneggi occorre eliminare le bave e gli spigoli taglienti presenti nella sede e sullo stelo.

È sempre consigliato lubrificare la tenuta prima del montaggio per agevolare l'inserimento dello stelo.

Per ulteriori informazioni leggere le istruzioni a p. 63.

RSA TYPE ROD SEAL

Description

The RSA seal has a dynamic lip shorter than the static one and it is used in cases of high rod misalignments and possible high pressure.

Technical data

Pressure: < 400 bar, at a temperature of 60° C
 Speed: < 0.5 m/s
 Temperature: from - 35° C to + 100° C, with peaks up to 110° C
 Fluids: mineral hydraulic fluids (see table 3, page 14)

Material

The proposed material is a "Co" type polyurethane, with high elasticity modulus, low compression-set and high abrasion resistance.

The hardness is 93 Shore A ± 2.

Compound reference: CO

Assembling

To prevent any damage to the seal, remove any flash and cutting edges in the housing and on the rod.

The seal should always be lubricated before assembling in order to have easier insertion of the rod. For further information please refer to the installation instructions on page 63.



RSA

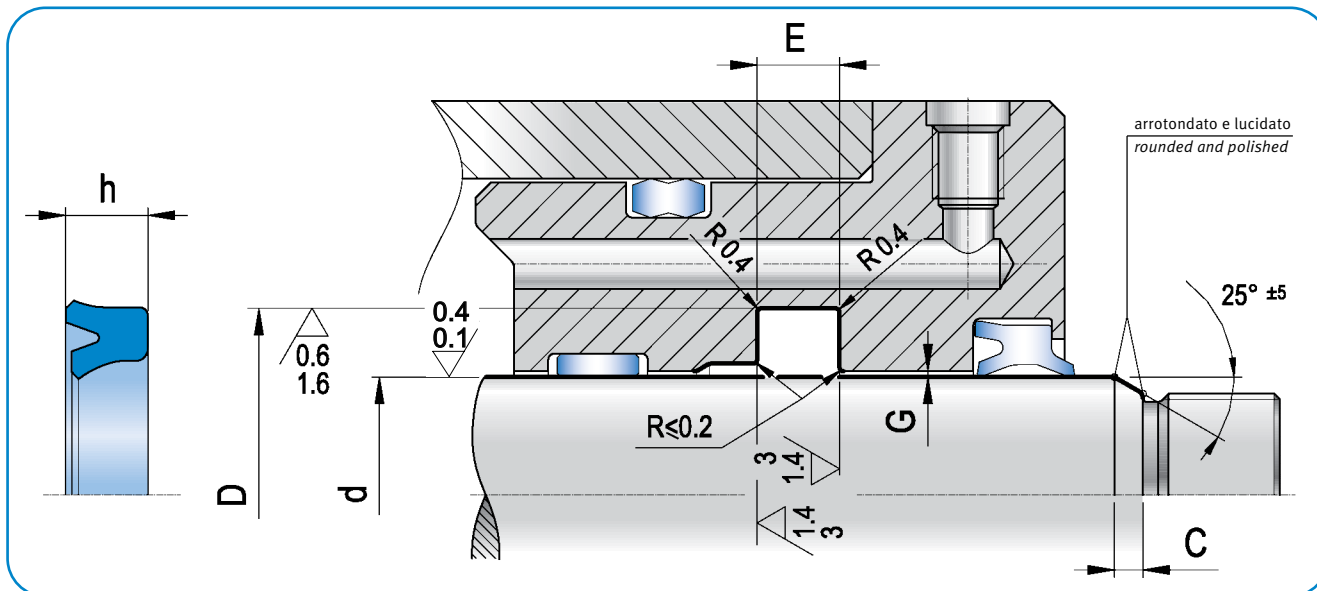
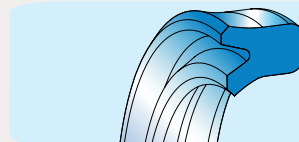

Oleodinamica
Hydraulic

d_{H9}	D_{H10}	h	$E_{+0,2}$	C	ART / ITEM	
*	6,0	14,0	5,7	6,3	3,5	RSA 0060 0140 057 Co
	8,0	16,0	4,7	5,3	3,5	RSA 0080 0160 047 Co
*	8,0	16,0	5,7	6,3	3,5	RSA 0080 0160 057 Co
	8,0	18,0	8,0	9,0	3,5	RSA 0080 0180 080 Co
	10,0	13,6	2,5	3,0	3,5	RSA 0100 0136 025 Co
*	10,0	18,0	5,7	6,3	3,5	RSA 0100 0180 057 Co
	10,0	20,0	7,2	8,0	4,5	RSA 0100 0200 072 Co
	11,0	17,0	4,5	5,0	4,5	RSA 0110 0170 045 Co
	12,0	19,0	5,0	5,5	3,5	RSA 0120 0190 050 Co
*	12,0	20,0	5,0	5,5	3,5	RSA 0120 0200 050 Co
*	12,0	20,0	5,7	6,4	3,5	RSA 0120 0200 057 Co
	12,0	22,0	4,7	5,3	4,5	RSA 0120 0220 047 Co
*	12,0	22,0	7,2	8,0	4,5	RSA 0120 0220 072 Co
	12,0	23,0	6,5	7,5	4,5	RSA 0120 0230 065 Co
*	14,0	22,0	5,7	6,3	3,5	RSA 0140 0220 057 Co
*	14,0	24,0	7,2	8,0	4,5	RSA 0140 0240 072 Co
	15,0	23,0	5,7	6,3	3,5	RSA 0150 0230 057 Co
	15,0	25,0	8,0	9,0	4,5	RSA 0150 0250 080 Co
	16,0	20,6	3,3	3,6	3,5	RSA 0160 0206 033 Co
	16,0	22,0	5,0	5,5	3,5	RSA 0160 0220 050 Co
*	16,0	24,0	5,7	6,3	3,5	RSA 0160 0240 057 Co
*	16,0	26,0	7,2	8,0	4,5	RSA 0160 0260 072 Co
	18,0	24,0	4,7	5,3	3,5	RSA 0180 0240 047 Co
*	18,0	26,0	5,7	6,3	3,5	RSA 0180 0260 057 Co
	18,0	26,0	8,0	9,0	3,5	RSA 0180 0260 080 Co
*	18,0	28,0	7,2	8,0	4,5	RSA 0180 0280 072 Co
	18,0	28,0	8,0	9,0	4,5	RSA 0180 0280 080 Co

d_{H9}	D_{H10}	h	$E_{+0,2}$	C	ART / ITEM	
	20,0	26,0	5,0	5,5	3,5	RSA 0200 0260 050 Co
*	20,0	28,0	5,7	6,3	3,5	RSA 0200 0280 057 Co
	20,0	28,0	6,2	7,0	3,5	RSA 0200 0280 062 Co
	20,0	28,0	7,2	8,0	3,5	RSA 0200 0280 072 Co
*	20,0	30,0	7,2	8,0	4,5	RSA 0200 0300 072 Co
	20,0	30,0	8,0	9,0	4,5	RSA 0200 0300 080 Co
	20,0	35,0	10,0	11,0	5,5	RSA 0200 0350 100 Co
	22,0	30,0	5,5	6,0	3,5	RSA 0220 0300 050 Co
*	22,0	30,0	5,7	6,4	3,5	RSA 0220 0300 057 Co
	22,0	30,0	8,0	9,0	3,5	RSA 0220 0300 080 Co
	22,0	32,0	7,2	8,0	4,5	RSA 0220 0320 072 Co
*	22,0	32,0	9,0	10,0	4,5	RSA 0220 0320 090 Co
	24,0	34,0	7,2	8,0	4,5	RSA 0240 0340 072 Co
	25,0	33,0	5,7	6,3	3,5	RSA 0250 0330 057 Co
*	25,0	33,0	6,3	7,0	3,5	RSA 0250 0330 063 Co
	25,0	33,0	7,2	8,0	3,5	RSA 0250 0330 072 Co
	25,0	33,0	10,0	11,0	3,5	RSA 0250 0330 010 Co
*	25,0	35,0	7,2	8,0	4,5	RSA 0250 0350 072 Co
	25,0	38,0	9,0	10,0	5,0	RSA 0250 0380 090 Co
	25,0	40,0	10,0	11,0	5,5	RSA 0250 0400 100 Co
	26,0	34,0	4,0	5,0	3,5	RSA 0260 0340 040 Co
	28,0	32,7	3,0	4,0	3,0	RSA 0280 0327 030 Co
	28,0	36,0	5,7	6,3	3,5	RSA 0280 0360 057 Co
*	28,0	38,0	7,2	8,0	4,5	RSA 0280 0380 072 Co
	28,0	38,0	8,0	9,0	4,5	RSA 0280 0380 080 Co
	28,0	38,0	10,0	11,0	4,5	RSA 0280 0380 100 Co
	28,0	40,0	8,5	9,5	4,5	RSA 0280 0400 085 Co

* in conformità alle norme ISO/DIN 5597 e ISO 5597/1 – in accordance with norms ISO/DIN 5597 and ISO 5597/1

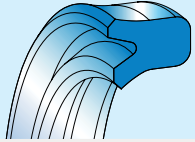

RSA

	d _{hg}	D _{H10}	h	E _{+0,2}	C	ART / ITEM		
*	28,0	43,0	11,5	12,5	5,5	RSA 0280	0430	115 Co
	30,0	38,0	5,7	6,3	3,5	RSA 0300	0380	057 Co
	30,0	38,0	8,0	9,0	3,5	RSA 0300	0380	080 Co
	30,0	40,0	5,7	6,3	4,5	RSA 0300	0400	057 Co
	30,0	40,0	7,2	8,0	4,5	RSA 0300	0400	072 Co
	30,0	40,0	9,5	10,5	4,5	RSA 0300	0400	095 Co
	30,0	40,0	10,0	11,0	4,5	RSA 0300	0400	100 Co
	30,0	43,0	9,0	10,0	4,5	RSA 0300	0430	090 Co
	30,0	45,0	8,0	9,0	5,5	RSA 0300	0450	080 Co
	32,0	40,0	5,7	6,3	3,5	RSA 0320	0400	057 Co
	32,0	40,0	8,0	9,0	3,5	RSA 0320	0400	080 Co
*	32,0	42,0	7,2	8,0	4,5	RSA 0320	0420	072 Co
	32,0	42,0	10,0	11,0	4,5	RSA 0320	0420	100 Co
	32,0	45,0	7,0	8,0	4,5	RSA 0320	0450	070 Co
	32,0	45,0	10,0	11,0	4,5	RSA 0320	0450	100 Co
	32,0	47,0	10,0	11,0	5,5	RSA 0320	0470	100 Co
	33,0	43,0	10,0	11,0	4,5	RSA 0330	0430	100 Co
	35,0	43,0	5,7	6,3	3,5	RSA 0350	0430	057 Co
	35,0	43,0	8,0	9,0	3,5	RSA 0350	0430	080 Co
	35,0	45,0	6,0	7,0	4,5	RSA 0350	0450	060 Co
	35,0	45,0	7,2	8,0	4,5	RSA 0350	0450	072 Co
	35,0	45,0	8,0	9,0	4,5	RSA 0350	0450	080 Co
	35,0	45,0	10,0	11,0	4,5	RSA 0350	0450	100 Co
	35,0	46,0	8,0	9,0	4,5	RSA 0350	0460	080 Co
	35,0	47,0	8,0	9,0	4,5	RSA 0350	0470	080 Co
	35,0	50,0	10,0	11,0	5,5	RSA 0350	0500	100 Co
	36,0	44,0	5,0	5,5	3,5	RSA 0360	0440	050 Co
	36,0	44,0	5,7	6,4	3,5	RSA 0360	0440	057 Co
	36,0	44,0	8,0	9,0	3,5	RSA 0360	0440	080 Co
*	36,0	46,0	7,2	8,0	4,5	RSA 0360	0460	072 Co
	36,0	46,0	10,0	11,0	4,5	RSA 0360	0460	100 Co
	36,0	48,0	7,0	8,0	4,5	RSA 0360	0480	070 Co
	36,0	48,0	8,0	9,0	4,5	RSA 0360	0480	080 Co
	36,0	51,0	10,0	11,0	5,5	RSA 0360	0510	100 Co
*	36,0	51,0	11,5	12,5	5,5	RSA 0360	0510	115 Co
	38,0	44,5	4,7	5,3	3,5	RSA 0380	0445	047 Co
	38,0	45,0	6,2	7,0	3,5	RSA 0380	0450	062 Co
	40,0	48,0	5,7	6,3	4,0	RSA 0400	0480	057 Co
	40,0	48,0	6,0	7,0	4,0	RSA 0400	0480	060 Co
	40,0	48,0	8,0	9,0	4,0	RSA 0400	0480	080 Co
*	40,0	50,0	7,2	8,0	4,5	RSA 0400	0500	072 Co
	40,0	50,0	9,0	10,0	4,5	RSA 0400	0500	090 Co
*	40,0	50,0	10,0	11,0	4,5	RSA 0400	0500	100 Co
	40,0	52,0	8,0	9,0	4,5	RSA 0400	0520	080 Co
	40,0	55,0	10,0	11,0	5,5	RSA 0400	0550	100 Co

	d _{hg}	D _{H10}	h	E _{+0,2}	C	ART / ITEM		
*	40,0	55,0	11,5	12,5	5,5	RSA 0400	0550	115 Co
	40,0	60,0	12,0	13,0	6,0	RSA 0400	0600	120 Co
	42,0	52,0	7,2	8,0	4,5	RSA 0420	0520	072 Co
	43,0	53,0	7,0	8,0	4,5	RSA 0430	0530	070 Co
	45,0	53,0	5,7	6,3	4,0	RSA 0450	0530	057 Co
	45,0	53,0	10,0	11,0	4,0	RSA 0450	0530	100 Co
*	45,0	55,0	7,2	8,0	4,5	RSA 0450	0550	072 Co
	45,0	55,0	10,0	11,0	4,5	RSA 0450	0550	100 Co
	45,0	58,0	9,0	10,0	5,0	RSA 0450	0580	090 Co
	45,0	60,0	10,0	11,0	5,5	RSA 0450	0600	100 Co
*	45,0	60,0	11,5	12,5	5,5	RSA 0450	0600	115 Co
	45,0	65,0	12,0	13,0	5,5	RSA 0450	0650	120 Co
	46,0	56,0	7,0	8,0	4,5	RSA 0460	0560	080 Co
*	50,0	60,0	7,2	8,0	4,5	RSA 0500	0600	072 Co
	50,0	60,0	10,0	11,0	4,5	RSA 0500	0600	100 Co
	50,0	60,0	12,0	13,0	4,5	RSA 0500	0600	120 Co
	50,0	62,0	9,0	10,0	5,0	RSA 0500	0620	090 Co
	50,0	63,0	10,0	11,0	5,0	RSA 0500	0630	100 Co
	50,0	65,0	10,0	11,0	5,5	RSA 0500	0650	100 Co
*	50,0	65,0	11,5	12,5	5,5	RSA 0500	0650	115 Co
	50,0	70,0	12,0	13,0	6,5	RSA 0500	0700	120 Co
	52,0	62,0	10,0	11,0	4,5	RSA 0520	0620	100 Co
	55,0	63,0	12,0	13,0	3,5	RSA 0550	0630	120 Co
	55,0	65,0	7,2	8,0	4,5	RSA 0550	0650	072 Co
	55,0	65,0	10,0	11,0	4,5	RSA 0550	0650	100 Co
	55,0	68,0	10,0	11,0	5,0	RSA 0550	0680	100 Co
	55,0	70,0	10,0	11,0	5,5	RSA 0550	0700	100 Co
	55,0	75,0	12,0	13,0	6,5	RSA 0550	0750	120 Co
	56,0	66,0	7,2	8,0	4,5	RSA 0560	0660	072 Co
	56,0	66,0	10,0	11,0	5,0	RSA 0560	0660	100 Co
	56,0	71,0	10,0	11,0	6,0	RSA 0560	0710	100 Co
*	56,0	71,0	11,5	12,5	6,0	RSA 0560	0710	115 Co
	56,0	71,0	12,5	13,5	6,0	RSA 0560	0710	125 Co
	56,0	76,0	12,0	13,0	6,5	RSA 0560	0760	120 Co
	56,0	76,0	15,0	16,0	6,5	RSA 0560	0760	150 Co
	60,0	68,0	12,5	13,5	4,5	RSA 0600	0680	125 Co
	60,0	70,0	5,0	36,0	5,0	RSA 0600	0700	050 Co
	60,0	70,0	7,2	8,0	5,0	RSA 0600	0700	072 Co
	60,0	70,0	8,0	9,0	5,0	RSA 0600	0700	080 Co
	60,0	70,0	10,0	11,0	5,0	RSA 0600	0700	100 Co
	60,0	72,0	8,0	9,0	5,5	RSA 0600	0720	080 Co
	60,0	72,0	9,0	10,0	5,5	RSA 0600	0720	090 Co
	60,0	73,0	10,0	11,0	5,5	RSA 0600	0730	100 Co
	60,0	75,0	10,0	11,0	6,0	RSA 0600	0750	100 Co
	60,0	75,0	11,5	12,5	6,0	RSA 0600	0750	115 Co

* in conformità alle norme ISO/DIN 5597 e ISO 5597/1 – in accordance with ISO/DIN 5597 and ISO 5597/1 norms



RSA

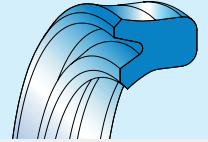

d _{H9}	D _{H10}	h	E _{+0,2}	C	ART / ITEM	
60,0	80,0	12,0	13,0	6,5	RSA 0600 0800 120 Co	
63,0	73,0	12,0	13,0	5,0	RSA 0630 0730 120 Co	
63,0	75,0	8,6	9,6	5,5	RSA 0630 0750 086 Co	
63,0	78,0	10,0	11,0	6,0	RSA 0630 0780 100 Co	
*	63,0	78,0	11,5	12,5	6,0	RSA 0630 0780 115 Co
	63,0	83,0	15,0	16,0	6,5	RSA 0630 0830 150 Co
	65,0	75,0	10,0	11,0	5,0	RSA 0650 0750 100 Co
	65,0	77,0	8,6	9,6	5,5	RSA 0650 0770 086 Co
	65,0	77,0	9,0	10,0	5,5	RSA 0650 0770 090 Co
	65,0	80,0	10,0	11,0	6,0	RSA 0650 0800 100 Co
	65,0	85,0	12,0	13,0	6,5	RSA 0650 0850 120 Co
*	70,0	80,0	7,2	8,0	5,0	RSA 0700 0800 072 Co
	70,0	80,0	12,0	13,0	5,0	RSA 0700 0800 120 Co
	70,0	82,0	8,6	9,6	6,0	RSA 0700 0820 086 Co
	70,0	85,0	10,0	11,0	6,0	RSA 0700 0850 100 Co
*	70,0	85,0	11,5	12,5	6,0	RSA 0700 0850 115 Co
*	70,0	85,0	12,0	13,0	6,0	RSA 0700 0850 120 Co
*	70,0	90,0	15,0	16,0	7,0	RSA 0700 0900 150 Co
	75,0	85,0	7,2	8,0	7,0	RSA 0750 0850 072 Co
	75,0	87,0	8,6	9,6	6,0	RSA 0750 0870 086 Co
	75,0	90,0	12,0	13,0	6,0	RSA 0750 0900 120 Co
	75,0	95,0	12,0	13,0	7,0	RSA 0750 0950 120 Co
	80,0	90,0	7,2	8,0	5,0	RSA 0800 0900 072 Co
	80,0	90,0	8,0	9,0	5,0	RSA 0800 0900 080 Co
	80,0	90,0	10,0	11,0	5,0	RSA 0800 0900 100 Co
	80,0	90,0	12,0	13,0	5,0	RSA 0800 0900 120 Co
	80,0	92,0	8,6	9,6	5,5	RSA 0800 0920 086 Co
	80,0	95,0	10,0	11,0	6,0	RSA 0800 0950 100 Co
*	80,0	95,0	11,5	12,5	6,0	RSA 0800 0950 115 Co
	80,0	95,0	12,0	13,0	6,0	RSA 0800 0950 120 Co
	80,0	100,0	12,0	13,0	7,0	RSA 0800 1000 120 Co
	80,0	100,0	12,5	13,5	7,0	RSA 0800 1000 125 Co
*	80,0	100,0	15,0	16,0	7,0	RSA 0800 1000 150 Co
	85,0	100,0	11,0	12,0	6,0	RSA 0850 1000 110 Co
	85,0	100,0	12,0	13,0	6,0	RSA 0850 1000 120 Co
	85,0	105,0	12,0	13,0	7,0	RSA 0850 1050 120 Co
	90,0	100,0	4,5	5,5	5,5	RSA 0900 1000 045 Co
	90,0	100,0	11,5	12,5	5,5	RSA 0900 1000 115 Co
*	90,0	105,0	8,5	9,5	6,0	RSA 0900 1050 085 Co

d _{H9}	D _{H10}	h	E _{+0,2}	C	ART / ITEM	
*	90,0	105,0	11,5	12,5	6,0	RSA 0900 1050 115 Co
*	90,0	105,0	12,0	13,0	6,0	RSA 0900 1050 120 Co
	90,0	110,0	12,0	13,0	7,0	RSA 0900 1100 120 Co
*	90,0	110,0	15,0	16,0	7,0	RSA 0900 1100 150 Co
	95,0	110,0	12,0	13,0	6,0	RSA 0950 1100 120 Co
	95,0	115,0	12,0	13,0	7,0	RSA 0950 1150 120 Co
	100,0	115,0	12,0	13,0	6,0	RSA 1000 1150 120 Co
*	100,0	120,0	12,0	13,0	7,0	RSA 1000 1200 120 Co
*	100,0	120,0	15,0	16,0	7,0	RSA 1000 1200 150 Co
*	100,0	125,0	19,0	20,0	8,0	RSA 1000 1250 190 Co
	105,0	120,0	11,5	12,5	6,0	RSA 1050 1200 115 Co
	105,0	125,0	12,0	13,0	7,0	RSA 1050 1250 120 Co
	105,0	125,0	15,0	16,0	7,0	RSA 1050 1250 150 Co
	110,0	125,0	11,0	12,0	6,0	RSA 1100 1250 110 Co
	110,0	125,0	12,0	13,0	6,0	RSA 1100 1250 120 Co
	110,0	130,0	12,0	13,0	7,0	RSA 1100 1300 120 Co
*	110,0	130,0	15,0	16,0	7,0	RSA 1100 1300 150 Co
	115,0	130,0	11,0	12,0	7,0	RSA 1150 1300 110 Co
	115,0	135,0	12,0	13,0	7,0	RSA 1150 1350 120 Co
	120,0	135,0	11,5	12,5	6,0	RSA 1200 1350 115 Co
	120,0	140,0	12,0	13,0	7,0	RSA 1200 1400 120 Co
	120,0	140,0	15,0	16,0	7,0	RSA 1200 1400 150 Co
*	125,0	145,0	15,0	16,0	7,0	RSA 1250 1450 150 Co
	130,0	150,0	12,0	13,0	7,0	RSA 1300 1500 120 Co
	130,0	150,0	15,0	16,0	7,0	RSA 1300 1500 150 Co
*	140,0	160,0	15,0	16,0	7,0	RSA 1400 1600 150 Co
	150,0	170,0	15,0	16,0	7,0	RSA 1500 1700 150 Co
	160,0	180,0	12,0	13,0	7,0	RSA 1600 1800 120 Co
	160,0	180,0	15,0	16,0	7,0	RSA 1600 1800 150 Co
	170,0	190,0	15,0	16,0	7,0	RSA 1700 1900 150 Co
	180,0	200,0	15,0	16,0	7,0	RSA 1800 2000 150 Co
	190,0	210,0	15,0	16,0	7,0	RSA 1900 2100 150 Co
	200,0	220,0	15,0	16,0	7,0	RSA 2000 2200 150 Co
	200,0	225,0	16,0	17,0	8,0	RSA 2000 2250 160 Co
	210,0	230,0	15,0	16,0	7,0	RSA 2100 2300 150 Co
	220,0	240,0	15,0	16,0	7,0	RSA 2200 2400 150 Co
	230,0	250,0	15,0	16,0	7,0	RSA 2300 2500 150 Co
	240,0	260,0	15,0	16,0	7,0	RSA 2400 2600 150 Co
	250,0	270,0	15,0	16,0	7,0	RSA 2500 2700 150 Co

* in conformità alle norme ISO/DIN 5597 e ISO 5597/1 - in accordance with ISO/DIN 5597 and ISO 5597/1 norms

Nota: altre dimensioni non a catalogo a richiesta. Consultare il nostro ufficio tecnico.

Remark: please contact our technical dept. for further dimensions not included in the catalogue.



RLF®

TENUTA STELO TIPO RLF®

Descrizione

La tenuta tipo RLF® ha un profilo innovativo rispetto alle tradizionali guarnizioni a labbro. Nella parte statica presenta un labbro molto lungo rispetto al labbro dinamico che resta vicino al fondo sede. In questo modo si genera pochissimo attrito in esercizio e il labbro si autoallinea perfettamente allo stelo. La base della guarnizione, sia nella parte dinamica sia in quella statica, ha due grossi raggi che facilitano il montaggio e contemporaneamente non creano spigoli che, sotto pressione, determinerebbero estrusione.

Dati tecnici

Pressione: < 400 bar a temperatura di 60° C
 Velocità: < 0.5 m/s
 Temperatura: da - 35° C a + 100° C con punte fino a 110° C
 Fluidi: fluidi a base minerale
 (v. tabella 3 a p. 14)

Materiale

Il materiale utilizzato e' un poliuretano tipo Co ad alto modulo elastico, basso compression-set ed elevata resistenza all'usura.
 Ha una durezza 93 Sh A ± 2
 Codice materiale: Co

Montaggio

Eliminare bave e spigoli vivi presenti nella sede e sullo stelo per evitare che la guarnizione si danneggi.

Importante: lo stelo deve avere uno smusso di invito molto curato per non rovesciare la guarnizione durante il montaggio. Fare riferimento alla tabella dimensionale qui di seguito per le quote consigliate per lo smusso. È sempre consigliato lubrificare la guarnizione prima del montaggio.

PIPE SEAL TYPE RLF®

Description

The RLF® seal has an innovative profile compared to traditional lip seals. In the static part, the lip is much longer than the dynamic lip and is close to the bottom of the housing. The friction thus generated during operation is very low and there is perfect auto-alignment with the rod. Two wide radii at the bottom of the seal, both in the dynamic and in the static section, considerably ease assembly and, at the same time, no edges develop under pressure, which would be a cause for extrusion. The contact surface at the bottom of the seal shows some roughness which, together with the notches, release the pressure generated by possible pumping movements.

Technical data

Pressure: < 400 bar, at a temperature of 60° C
 Speed: < 0.5 m/s
 Temperature: from - 35° C to + 100° C, with peaks up to 110° C
 Fluids: mineral fluids
 (see table 3, page 14)

Material

*The material used is a Co-type polyurethane with high elasticity modulus, low compression-set and high resistance to wear.
 The hardness is 93 Sh A ± 2
 Compound reference: Co*

Assembling

To prevent any damage to the seal, remove any flash and sharp edges in the housing and on the rod.

Warning: the rod needs a very accurate lead-in chamfer in order not to distort the seal during assembly. Please refer to the dimensional table below for the recommended dimensions for the lead-in chamfer. The seal should always be lubricated before assembly.

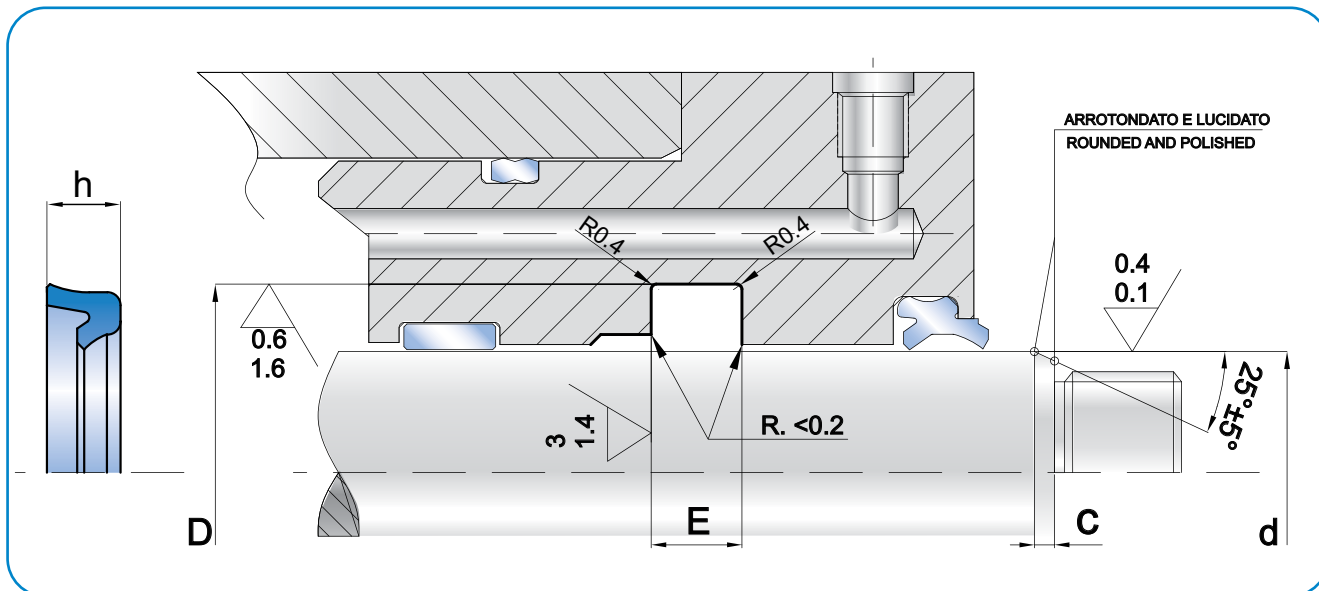
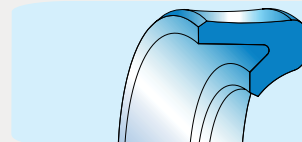
**RLF®**

d_{H9}	D_{H10}	h	$E_{+0,2}$	C	ART / ITEM
3,5	7,5	4,0	4,5	3,5	RLF 0035 0075 040 Co
4,0	7,4	3,0	3,5	3,5	RLF 0040 0074 030 Co
6,0	9,0	3,5	4,0	3,5	RLF 0060 0090 035 Co
6,0	9,5	3,5	4,0	3,5	RLF 0060 0095 035 Co
7,5	12,5	3,5	4,0	3,5	RLF 0075 0125 035 Co
8,0	13,0	3,5	4,0	3,5	RLF 0080 0130 035 Co
8,0	14,1	5,6	6,3	4,0	RLF 0080 0141 056 Co
9,0	14,0	3,5	4,0	3,5	RLF 0090 0140 035 Co
10,0	15,0	3,5	4,0	3,5	RLF 0100 0150 035 Co
10,0	16,0	4,5	5,5	3,5	RLF 0100 0160 045 Co
11,0	16,0	3,5	4,0	3,5	RLF 0110 0160 035 Co
12,0	17,0	3,5	4,0	3,5	RLF 0120 0170 035 Co
15,0	20,0	4,5	5,5	4,0	RLF 0150 0200 045 Co
20,0	26,0	4,8	5,5	4,0	RLF 0200 0260 048 Co
25,0	33,0	4,5	5,5	4,0	RLF 0250 0330 045 Co
25,0	33,0	5,7	6,3	4,0	RLF 0250 0330 057 Co
28,0	36,0	5,7	6,3	4,0	RLF 0280 0360 057 Co
30,0	40,0	10,0	11,0	4,5	RLF 0300 0400 100 Co
32,0	42,0	7,3	8,0	4,0	RLF 0320 0420 073 Co
35,0	45,0	7,3	8,0	4,0	RLF 0350 0450 073 Co
36,0	44,0	5,7	6,3	4,0	RLF 0360 0440 057 Co
40,0	48,0	6,3	7,0	4,0	RLF 0400 0480 063 Co
40,0	50,0	7,3	8,0	4,5	RLF 0400 0500 073 Co
40,0	50,0	10,0	11,0	4,5	RLF 0400 0500 100 Co
45,0	55,0	7,3	8,0	4,5	RLF 0450 0550 073 Co
50,0	60,0	7,3	8,0	4,5	RLF 0500 0600 073 Co
50,0	60,0	9,0	10,0	4,5	RLF 0500 0600 090 Co



RLF®

d _{hg}	D _{H10}	h	E _{+0,2}	C	ART / ITEM
50,0	60,0	10,0	11,0	4,5	RLF 0500 0600 100 Co
50,0	65,0	10,0	11,0	5,5	RLF 0500 0650 100 Co
50,0	65,0	11,5	12,5	5,5	RLF 0500 0650 115 Co
50,8	66,7	11,5	12,5	5,5	RLF 0508 0667 115 Co
51,0	59,0	7,5	8,5	5,5	RLF 0510 0590 075 Co
55,0	65,0	7,3	8,0	4,5	RLF 0550 0650 073 Co
55,0	65,0	9,0	10,0	4,5	RLF 0550 0650 090 Co
60,0	68,0	6,0	7,0	4,5	RLF 0600 0680 060 Co
60,0	70,0	7,3	8,0	4,5	RLF 0600 0700 073 Co
60,0	70,0	9,0	10,0	4,5	RLF 0600 0700 090 Co
60,0	70,0	10,0	11,0	4,5	RLF 0600 0700 100 Co
60,0	75,0	11,5	12,5	5,5	RLF 0600 0750 115 Co
60,0	75,0	12,0	13,0	5,5	RLF 0600 0750 120 Co
63,0	78,0	11,5	12,5	5,5	RLF 0630 0780 115 Co
65,0	75,0	7,3	8,0	4,5	RLF 0650 0750 073 Co
65,0	75,0	9,0	10,0	4,5	RLF 0650 0750 090 Co
65,0	75,0	10,0	11,0	4,5	RLF 0650 0750 100 Co
66,0	74,0	9,0	10,0	4,5	RLF 0660 0740 090 Co
70,0	80,0	7,3	8,0	4,5	RLF 0700 0800 073 Co
70,0	80,0	10,0	11,0	4,5	RLF 0700 0800 100 Co
70,0	84,0	11,5	12,5	4,5	RLF 0700 0840 115 Co
70,0	85,0	11,5	12,5	5,5	RLF 0700 0850 115 Co
75,0	82,5	7,3	8,0	4,5	RLF 0750 0825 073 Co
75,0	85,0	7,3	8,0	4,5	RLF 0750 0850 073 Co
75,0	85,0	10,0	11,0	4,5	RLF 0750 0850 100 Co
75,0	90,0	11,5	12,5	4,5	RLF 0750 0900 115 Co
80,0	95,0	11,5	12,5	5,5	RLF 0800 0950 115 Co
80,0	100,0	13,5	14,5	5,5	RLF 0800 1000 135 Co
85,0	95,0	7,3	8,0	4,5	RLF 0850 0950 073 Co
85,0	95,0	10,0	11,0	4,5	RLF 0850 0950 100 Co
85,0	105,0	13,5	14,5	5,5	RLF 0850 1050 135 Co
90,0	100,0	6,7	7,5	4,5	RLF 0900 1000 067 Co
90,0	100,0	10,0	11,0	4,5	RLF 0900 1000 100 Co
90,0	105,0	11,5	12,5	5,5	RLF 0900 1050 115 Co
90,0	110,0	11,5	12,5	5,5	RLF 0900 1100 115 Co
95,0	110,0	11,5	12,5	5,5	RLF 0950 1100 115 Co
100,0	120,0	11,5	12,5	5,5	RLF 1000 1200 115 Co
100,0	120,0	15,0	16,0	6,0	RLF 1000 1200 150 Co
105,0	120,0	11,5	12,5	5,5	RLF 1050 1200 115 Co
105,0	125,0	15,0	16,0	6,0	RLF 1050 1250 150 Co
110,0	130,0	11,5	12,5	5,5	RLF 1100 1300 115 Co
110,0	130,0	15,0	16,0	6,0	RLF 1100 1300 150 Co
120,0	135,0	11,5	12,5	5,5	RLF 1200 1350 115 Co
120,0	135,0	15,0	16,0	5,5	RLF 1200 1350 160 Co
120,0	140,0	11,5	12,5	5,5	RLF 1200 1400 115 Co

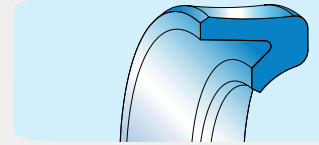
**RLF®**

d_{H9}	D_{H10}	h	$E_{+0,2}$	C	ART / ITEM
120,0	140,0	15,0	16,0	6,0	RLF 1200 1400 150 Co
125,0	145,0	15,0	16,0	6,0	RLF 1250 1450 150 Co
130,0	145,0	14,0	15,0	6,0	RLF 1300 1450 140 Co
150,0	165,0	12,0	13,0	6,0	RLF 1500 1650 120 Co
160,0	175,0	14,0	15,0	6,0	RLF 1600 1750 140 Co
180,0	195,0	11,5	12,5	6,0	RLF 1800 1950 115 Co
200,0	220,0	13,5	14,5	6,0	RLF 2000 2200 135 Co

Nota: altre dimensioni non a catalogo a richiesta. Consultare il nostro ufficio tecnico.

Remark: please contact our technical dept. for further dimensions not included in the catalogue.

Fig. 26- Pic.26:

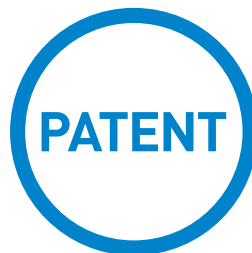
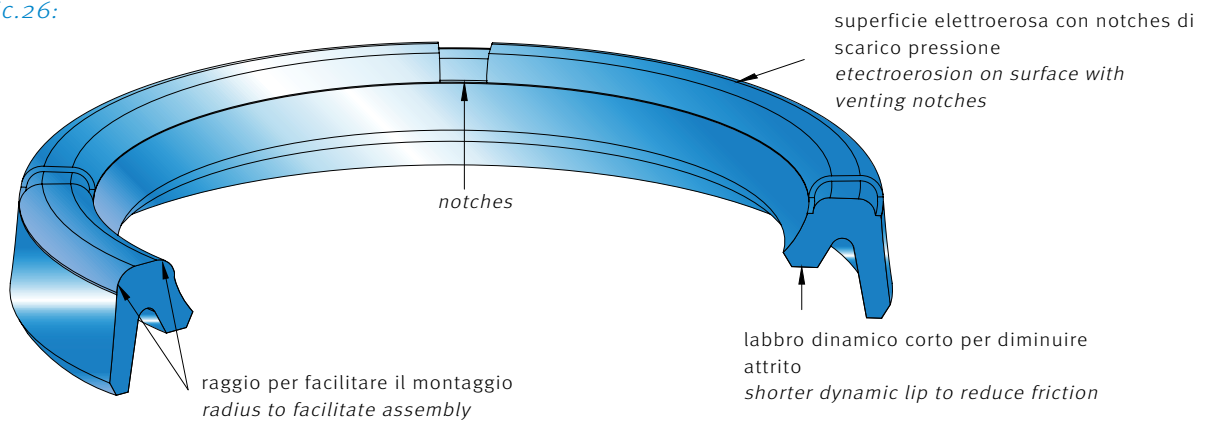

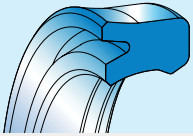

RSB

TENUTA STELO TIPO RSB

Descrizione

La guarnizione tipo RSB è molto simile al tipo RSA ma sul lato dinamico, ossia sul diametro interno, presenta due labbri con più funzioni:

- attenua eventuali fenomeni di stick-slip grazie al fluido trattenuto nell'intercapedine fra i due labbri
- evita l'entrata di impurità dall'esterno
- contrasta il ritiro del materiale alle basse temperature
- funge da stabilizzatore.

Dati tecnici

Pressione: < 400 bar a temperatura di 60° C
 Velocità: < 0.5 m/s
 Temperatura: da - 35° C a + 100° C con punte fino a 110° C
 Fluidi: fluidi idraulici a base minerale (v. tabella 3 a p. 14)

Materiale

Il materiale proposto è il poliuretano tipo Co ad alto modulo elastico, basso compression-set ed elevata resistenza all'abrasione.

Ha un durezza di 93 Shore A ± 2.

Codice materiale: Co

Montaggio

Eliminare bave e spigoli taglienti presenti nella sede e sullo stelo per evitare che la guarnizione si danneggi. È sempre consigliato lubrificare la tenuta prima del montaggio per agevolare l'inserimento dello stelo.

Per ulteriori informazioni leggere le istruzioni a p. 63.

RSB TYPE ROD SEAL

Description

The RSB seal type is similar to the RSA type, but on the dynamic side, it presents a multifunctional double lip which:

- reduces stick-slip effects thanks because it keeps oil between the secondary lip and the main one
- stops any external impurities
- faces the material shrinkage at low temperatures
- acts as a stabilizer.

Technical data

Pressure: < 400 bar at a temperature of 60° C
 Speed: < 0.5 m/s
 Temperature: from - 35° C to + 100° C with peaks till 110° C
 Fluids: mineral hydraulic fluids (see table 3, page 14)

Material

The proposed material is a "Co" type polyurethane, with high elasticity modulus, low compression-set and high abrasion resistance.

The hardness is 93 Shore A ± 2.

Compound reference: Co

Assembling

To prevent any damage to the seal, remove any flash and cutting edges in the housing and on the rod.

The seal should always be lubricated before assembling in order to have easier insertion of the rod.

For further information please refer to the installation instructions on page 63.



RSB

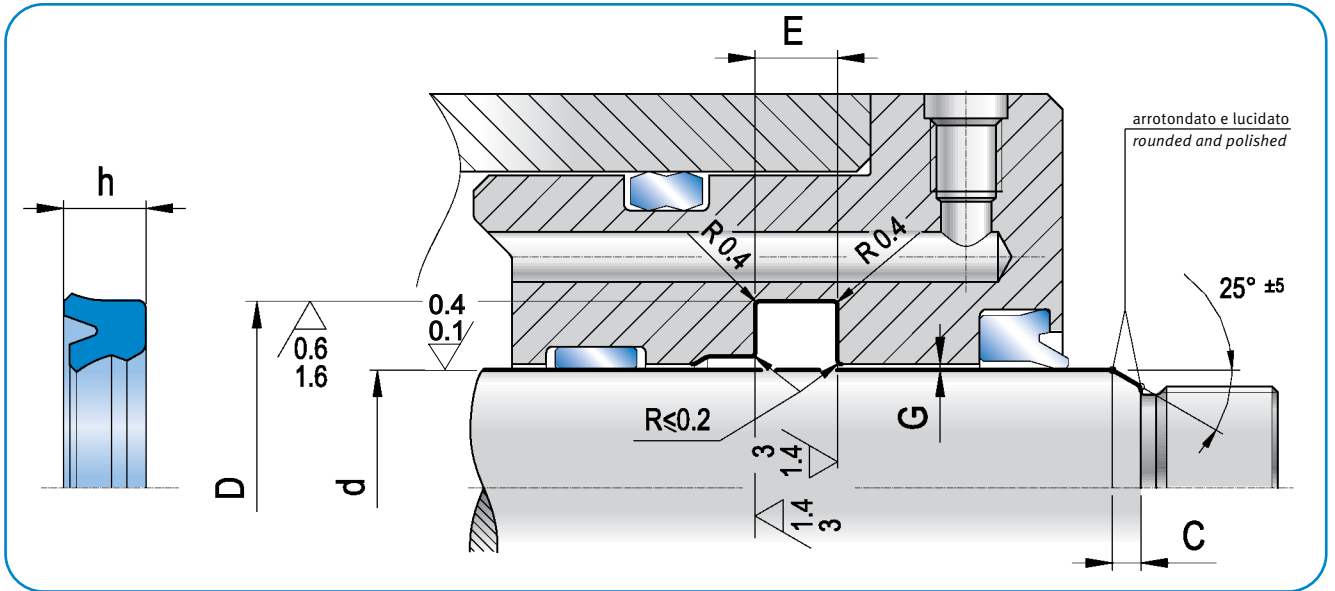
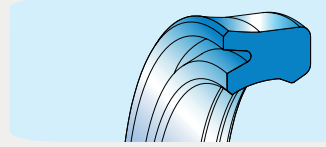

d _{H9}	D _{H10}	h	E _{+0,2}	C	ART / ITEM
6,0	14,0	5,7	6,3	3,5	RSB 0060 0140 057 Co
8,0	16,0	5,7	6,3	3,5	RSB 0080 0160 057 Co
10,0	18,0	5,7	6,3	3,5	RSB 0100 0180 057 Co
10,0	20,0	7,0	8,0	4,5	RSB 0100 0200 070 Co
12,0	17,0	3,6	4,0	3,5	RSB 0120 0170 036 Co
12,0	19,0	5,0	5,6	3,5	RSB 0120 0190 050 Co
12,0	20,0	5,7	6,3	4,0	RSB 0120 0200 057 Co
12,0	22,0	7,0	8,0	4,5	RSB 0120 0220 070 Co
12,0	22,0	8,0	9,0	4,5	RSB 0120 0220 080 Co
14,0	20,0	5,8	6,3	4,0	RSB 0140 0200 058 Co
14,0	21,0	5,0	5,6	4,0	RSB 0140 0210 050 Co
14,0	22,0	5,7	6,3	4,0	RSB 0140 0220 057 Co
14,0	24,0	7,3	8,0	4,5	RSB 0140 0240 073 Co
15,0	21,0	5,0	6,0	3,5	RSB 0150 0210 050 Co
15,0	23,0	5,7	6,3	4,0	RSB 0150 0230 057 Co
16,0	20,6	3,3	4,0	3,0	RSB 0160 0206 033 Co
16,0	22,0	5,0	6,0	3,5	RSB 0160 0220 050 Co
16,0	24,0	5,7	6,3	4,0	RSB 0160 0240 057 Co
16,0	26,0	7,3	8,0	4,5	RSB 0160 0260 073 Co
18,0	25,0	5,0	5,6	3,5	RSB 0180 0250 050 Co
18,0	26,0	6,3	7,0	3,5	RSB 0180 0260 063 Co
18,0	26,0	5,7	6,3	4,0	RSB 0180 0260 057 Co
18,0	28,0	7,3	8,0	4,5	RSB 0180 0280 073 Co
20,0	26,0	5,0	6,0	3,5	RSB 0200 0260 050 Co
20,0	28,0	4,3	5,0	4,0	RSB 0200 0280 043 Co
20,0	28,0	5,0	6,0	4,0	RSB 0200 0280 050 Co
20,0	28,0	5,7	6,3	4,0	RSB 0200 0280 057 Co
20,0	30,0	7,3	8,0	4,5	RSB 0200 0300 073 Co
20,0	32,0	7,5	8,5	4,5	RSB 0200 0320 075 Co
22,0	28,0	5,0	6,0	3,5	RSB 0220 0280 050 Co

d _{H9}	D _{H10}	h	E _{+0,2}	C	ART / ITEM
22,0	29,0	5,0	5,6	3,5	RSB 0220 0290 050 Co
22,0	30,0	5,5	6,0	4,5	RSB 0220 0300 055 Co
22,0	30,0	5,7	6,3	4,5	RSB 0220 0300 057 Co
22,0	30,0	6,2	7,0	4,5	RSB 0220 0300 062 Co
22,0	32,0	7,3	8,0	4,5	RSB 0220 0320 073 Co
25,0	33,0	5,7	6,3	4,0	RSB 0250 0330 057 Co
25,0	33,0	6,0	7,0	4,5	RSB 0250 0330 060 Co
25,0	33,0	7,3	8,0	4,5	RSB 0250 0330 073 Co
25,0	35,0	7,3	8,0	4,5	RSB 0250 0350 073 Co
25,0	35,0	10,0	11,0	4,5	RSB 0250 0350 100 Co
26,0	34,0	5,7	6,3	4,0	RSB 0260 0340 057 Co
28,0	36,0	5,7	6,3	4,0	RSB 0280 0360 057 Co
28,0	36,0	7,3	8,0	4,0	RSB 0280 0360 073 Co
28,0	38,0	5,7	6,3	4,5	RSB 0280 0380 057 Co
28,0	38,0	7,3	8,0	4,5	RSB 0280 0380 073 Co
28,0	38,0	8,0	9,0	4,5	RSB 0280 0380 080 Co
28,0	43,0	11,5	12,5	5,0	RSB 0280 0430 115 Co
30,0	38,0	5,7	6,3	4,0	RSB 0300 0380 057 Co
30,0	38,0	6,0	7,0	4,5	RSB 0300 0380 060 Co
30,0	40,0	6,0	7,0	4,5	RSB 0300 0400 060 Co
30,0	40,0	7,3	8,0	4,5	RSB 0300 0400 073 Co
30,0	40,0	8,0	9,0	4,5	RSB 0300 0400 080 Co
32,0	39,0	3,5	4,5	4,0	RSB 0320 0390 035 Co
32,0	40,0	5,7	6,3	4,0	RSB 0320 0400 057 Co
32,0	40,0	6,0	7,0	4,0	RSB 0320 0400 060 Co
32,0	40,0	6,7	7,7	4,0	RSB 0320 0400 067 Co
32,0	42,0	5,7	6,3	4,5	RSB 0320 0420 057 Co
32,0	42,0	6,0	7,0	4,5	RSB 0320 0420 060 Co
32,0	42,0	7,3	8,0	4,5	RSB 0320 0420 073 Co
35,0	42,0	7,0	8,0	4,0	RSB 0350 0420 070 Co

Oleodinamica
 Hydraulic

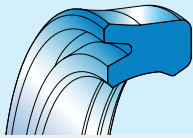

RSB

d _{hg}	D _{H10}	h	E _{+0,2}	C	ART / ITEM
35,0	43,0	5,7	6,3	4,0	RSB 0350 0430 057 Co
35,0	43,0	6,0	7,0	5,0	RSB 0350 0430 060 Co
35,0	45,0	6,0	7,0	5,0	RSB 0350 0450 060 Co
35,0	45,0	6,7	7,7	5,0	RSB 0350 0450 067 Co
35,0	45,0	7,0	8,0	5,0	RSB 0350 0450 070 Co
35,0	45,0	7,3	8,0	5,0	RSB 0350 0450 073 Co
35,0	45,0	8,0	9,0	5,0	RSB 0350 0450 080 Co
35,0	45,0	12,0	13,0	5,0	RSB 0350 0450 120 Co
35,0	50,0	9,0	10,0	5,5	RSB 0350 0500 090 Co
36,0	44,0	5,7	6,3	4,5	RSB 0360 0440 057 Co
36,0	44,0	6,3	7,0	4,5	RSB 0360 0440 063 Co
36,0	46,0	7,0	8,0	5,0	RSB 0360 0460 070 Co
36,0	46,0	7,3	8,0	5,0	RSB 0360 0460 073 Co
36,0	46,0	8,0	9,0	5,0	RSB 0360 0460 080 Co
37,0	47,0	7,2	8,0	5,0	RSB 0370 0470 072 Co
38,0	48,0	8,0	9,0	5,0	RSB 0380 0480 080 Co
40,0	48,0	5,7	6,3	4,5	RSB 0400 0480 057 Co
40,0	50,0	6,0	7,0	4,5	RSB 0400 0500 060 Co
40,0	50,0	7,0	8,0	5,0	RSB 0400 0500 070 Co
40,0	50,0	7,3	8,0	5,0	RSB 0400 0500 073 Co
40,0	50,0	10,0	11,0	5,0	RSB 0400 0500 100 Co
40,0	52,0	8,0	9,0	5,5	RSB 0400 0520 080 Co
40,0	55,0	10,0	11,0	5,5	RSB 0400 0550 100 Co
40,0	55,0	11,5	12,5	5,5	RSB 0400 0550 115 Co
40,0	55,0	9,0	10,0	5,5	RSB 0400 0550 090 Co
40,0	56,0	6,0	7,0	5,5	RSB 0400 0550 090 Co
42,0	50,0	8,0	9,0	4,5	RSB 0420 0500 080 Co
42,0	50,0	11,5	12,5	4,5	RSB 0420 0500 115 Co
42,0	53,0	9,0	10,0	5,0	RSB 0420 0530 090 Co
45,0	53,0	5,7	6,3	4,5	RSB 0450 0530 057 Co
45,0	53,0	10,0	11,0	4,5	RSB 0450 0530 100 Co
45,0	53,0	11,5	12,5	4,5	RSB 0450 0530 115 Co
45,0	55,0	5,7	6,3	5,0	RSB 0450 0550 057 Co
45,0	55,0	6,0	7,0	4,5	RSB 0450 0550 060 Co
45,0	55,0	7,3	8,0	5,0	RSB 0450 0550 073 Co
45,0	55,0	11,5	12,5	5,0	RSB 0450 0550 115 Co
45,0	60,0	11,5	12,5	5,5	RSB 0450 0600 115 Co
46,0	56,0	10,0	11,0	5,0	RSB 0460 0560 100 Co
48,0	56,0	11,5	12,5	4,5	RSB 0480 0560 115 Co
48,0	56,0	12,0	13,0	4,5	RSB 0480 0560 120 Co
50,0	57,0	7,3	8,0	4,5	RSB 0500 0570 073 Co
50,0	57,0	10,0	11,0	4,5	RSB 0500 0570 100 Co
50,0	58,0	6,0	7,0	4,5	RSB 0500 0580 060 Co
50,0	58,0	11,5	12,5	4,5	RSB 0500 0580 115 Co
50,0	58,9	5,8	6,5	5,0	RSB 0500 0589 058 Co
50,0	59,0	10,0	11,0	5,0	RSB 0500 0590 100 Co
50,0	60,0	6,0	7,0	4,5	RSB 0500 0600 060 Co
50,0	60,0	7,3	8,0	5,0	RSB 0500 0600 073 Co

d _{hg}	D _{H10}	h	E _{+0,2}	C	ART / ITEM
50,0	60,0	10,0	11,0	5,0	RSB 0500 0600 100 Co
50,0	65,0	9,0	10,0	5,5	RSB 0500 0650 090 Co
50,0	65,0	10,0	11,0	5,5	RSB 0500 0650 100 Co
50,0	65,0	11,5	12,5	5,5	RSB 0500 0650 115 Co
50,0	70,0	10,0	11,0	6,0	RSB 0500 0700 100 Co
50,0	70,0	12,0	13,0	7,0	RSB 0500 0700 120 Co
51,0	61,0	6,0	7,0	4,5	RSB 0510 0610 060 Co
52,0	62,0	7,2	8,0	4,5	RSB 0520 0620 072 Co
55,0	63,0	11,5	12,5	4,5	RSB 0550 0630 115 Co
55,0	65,0	6,0	7,0	4,5	RSB 0550 0650 060 Co
55,0	65,0	7,3	8,0	5,0	RSB 0550 0650 073 Co
55,0	65,0	8,5	9,5	5,0	RSB 0550 0650 085 Co
55,0	65,0	10,0	11,0	5,0	RSB 0550 0650 100 Co
55,0	68,0	10,0	11,0	5,0	RSB 0550 0680 100 Co
55,0	70,0	9,0	10,0	5,5	RSB 0550 0700 090 Co
55,0	75,0	12,0	13,0	5,0	RSB 0550 0750 120 Co
56,0	66,0	6,0	7,0	5,0	RSB 0560 0660 060 Co
56,0	71,0	5,6	6,3	5,0	RSB 0560 0660 060 Co
56,0	71,0	9,0	10,0	5,5	RSB 0560 0710 090 Co
56,0	71,0	10,0	11,0	5,5	RSB 0560 0710 100 Co
56,0	71,0	11,5	12,5	5,5	RSB 0560 0710 115 Co
56,0	76,0	15,0	16,0	6,0	RSB 0560 0760 150 Co
60,0	68,0	11,5	12,5	4,5	RSB 0600 0680 115 Co
60,0	70,0	6,0	7,0	5,0	RSB 0600 0700 060 Co
60,0	70,0	7,3	8,0	5,0	RSB 0600 0700 073 Co
60,0	70,0	10,0	11,0	5,0	RSB 0600 0700 100 Co
60,0	70,0	11,5	12,5	5,0	RSB 0600 0700 115 Co
60,0	73,0	10,0	11,0	5,5	RSB 0600 0730 100 Co
60,0	75,0	9,0	10,0	5,5	RSB 0600 0750 090 Co
60,0	75,0	10,0	11,0	5,5	RSB 0600 0750 100 Co
60,0	75,0	11,5	12,5	5,5	RSB 0600 0750 115 Co
60,0	80,0	12,0	13,0	7,0	RSB 0600 0800 120 Co
63,0	73,0	6,0	7,0	5,0	RSB 0630 0730 060 Co
63,0	73,0	12,0	13,0	5,0	RSB 0630 0730 120 Co
63,0	78,0	10,0	11,0	5,5	RSB 0630 0780 100 Co
63,0	78,0	11,5	12,5	5,5	RSB 0630 0780 115 Co
63,0	83,0	12,0	13,0	7,0	RSB 0630 0830 120 Co
63,0	83,0	15,0	16,0	7,0	RSB 0630 0830 150 Co
65,0	73,0	11,5	12,5	4,5	RSB 0650 0730 115 Co
65,0	75,0	6,0	7,0	5,0	RSB 0650 0750 060 Co
65,0	75,0	7,0	8,0	5,5	RSB 0650 0750 070 Co
65,0	75,0	7,3	8,0	5,0	RSB 0650 0750 073 Co
65,0	75,0	10,0	11,0	5,0	RSB 0650 0750 100 Co
65,0	75,0	12,0	13,0	5,5	RSB 0650 0750 120 Co
65,0	78,0	10,0	11,0	5,5	RSB 0650 0780 100 Co
65,0	80,0	9,0	10,0	5,5	RSB 0650 0800 090 Co
65,0	80,0	11,5	12,5	5,5	RSB 0650 0800 115 Co
65,0	85,0	12,0	13,0	7,0	RSB 0650 0850 120 Co



RSB

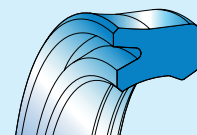

d _{h9}	D _{H10}	h	E _{+0,2}	C	ART / ITEM
66,3	76,3	11,5	12,5	5,0	RSB 0663 0763 115 Co
67,0	75,0	11,5	12,5	5,0	RSB 0670 0750 115 Co
67,0	77,0	6,0	7,0	5,0	RSB 0670 0770 060 Co
68,0	78,0	7,3	8,0	5,0	RSB 0680 0780 073 Co
70,0	78,0	11,5	12,5	4,5	RSB 0700 0780 115 Co
70,0	80,0	6,0	7,0	5,0	RSB 0700 0800 060 Co
70,0	80,0	7,3	8,0	5,5	RSB 0700 0800 073 Co
70,0	80,0	11,5	12,5	5,0	RSB 0700 0800 115 Co
70,0	83,0	10,0	11,0	5,5	RSB 0700 0830 100 Co
70,0	85,0	9,0	10,0	5,5	RSB 0700 0850 090 Co
70,0	85,0	10,0	11,0	5,5	RSB 0700 0850 100 Co
70,0	85,0	11,5	12,5	6,0	RSB 0700 0850 115 Co
70,0	90,0	12,0	13,0	7,0	RSB 0700 0900 120 Co
70,0	90,0	15,0	16,0	7,0	RSB 0700 0900 150 Co
71,0	81,0	6,0	7,0	5,0	RSB 0710 0810 060 Co
71,0	81,0	8,0	9,0	5,0	RSB 0710 0810 080 Co
75,0	83,0	7,0	8,0	5,0	RSB 0750 0830 070 Co
75,0	83,0	11,5	12,5	5,0	RSB 0750 0830 115 Co
75,0	85,0	6,0	7,0	5,5	RSB 0750 0850 060 Co
75,0	85,0	10,0	11,0	5,5	RSB 0750 0850 100 Co
75,0	85,0	11,5	12,5	5,5	RSB 0750 0850 115 Co
75,0	88,0	10,0	11,0	5,5	RSB 0750 0880 100 Co
75,0	90,0	9,0	10,0	5,5	RSB 0750 0900 090 Co
75,0	90,0	11,5	12,5	6,0	RSB 0750 0900 115 Co
75,0	95,0	12,0	13,0	7,0	RSB 0750 0950 120 Co
77,0	87,0	7,2	8,0	5,0	RSB 0770 0870 072 Co
78,0	86,0	11,5	12,5	5,0	RSB 0780 0860 115 Co
80,0	88,0	11,5	12,5	5,0	RSB 0800 0880 115 Co
80,0	89,6	5,8	6,5	5,5	RSB 0800 0896 058 Co
80,0	90,0	6,0	7,0	5,5	RSB 0800 0900 060 Co
80,0	90,0	7,3	8,0	5,5	RSB 0800 0900 073 Co
80,0	90,0	10,0	11,0	5,5	RSB 0800 0900 100 Co
80,0	93,0	10,0	11,0	5,5	RSB 0800 0930 100 Co
80,0	95,0	9,0	10,0	6,0	RSB 0800 0950 090 Co
80,0	95,0	10,0	11,0	6,0	RSB 0800 0950 100 Co
80,0	95,0	11,5	12,5	6,0	RSB 0800 0950 115 Co
80,0	100,0	12,0	13,0	7,0	RSB 0800 1000 120 Co
80,0	100,0	15,0	16,0	7,0	RSB 0800 1000 150 Co
85,0	93,0	11,5	12,5	5,0	RSB 0850 0930 115 Co
85,0	100,0	9,0	10,0	6,0	RSB 0850 1000 090 Co
85,0	100,0	10,0	11,0	6,0	RSB 0850 1000 100 Co
85,0	100,0	11,5	12,5	6,0	RSB 0850 1000 115 Co
85,0	105,0	12,0	13,0	7,0	RSB 0850 1050 120 Co
90,0	98,0	11,5	12,5	5,0	RSB 0900 0980 115 Co
90,0	100,0	7,3	8,0	5,5	RSB 0900 1000 073 Co
90,0	100,0	11,5	12,5	5,5	RSB 0900 1000 115 Co
90,0	105,0	9,0	10,0	6,0	RSB 0900 1050 090 Co
90,0	105,0	10,0	11,0	6,0	RSB 0900 1050 100 Co

d _{h9}	D _{H10}	h	E _{+0,2}	C	ART / ITEM
90,0	105,0	11,5	12,5	6,0	RSB 0900 1050 115 Co
90,0	110,0	12,0	13,0	7,0	RSB 0900 1100 120 Co
90,0	110,0	15,0	16,0	7,0	RSB 0900 1100 150 Co
93,0	101,0	11,5	12,5	5,0	RSB 0930 1010 115 Co
95,0	103,0	11,5	12,5	5,0	RSB 0950 1030 115 Co
95,0	105,0	12,0	13,0	5,5	RSB 0950 1050 120 Co
95,0	110,0	9,0	10,0	7,0	RSB 0950 1100 090 Co
95,0	110,0	10,0	11,0	6,0	RSB 0950 1100 100 Co
95,0	115,0	12,0	13,0	7,0	RSB 0950 1150 120 Co
95,0	115,0	13,5	14,5	5,5	RSB 0950 1150 135 Co
97,0	105,0	11,5	12,5	5,0	RSB 0970 1050 115 Co
100,0	108,0	11,5	12,5	5,5	RSB 1000 1080 115 Co
100,0	115,0	9,0	10,0	6,0	RSB 1000 1150 090 Co
100,0	115,0	10,0	11,0	6,0	RSB 1000 1150 100 Co
100,0	115,0	12,0	13,0	6,0	RSB 1000 1150 120 Co
100,0	120,0	11,8	13,0	7,0	RSB 1000 1200 118 Co
100,0	120,0	12,0	13,0	7,0	RSB 1000 1200 120 Co
100,0	120,0	15,0	16,0	7,0	RSB 1000 1200 150 Co
105,0	113,0	11,5	12,5	5,0	RSB 1050 1130 115 Co
105,0	115,0	11,5	12,5	5,5	RSB 1050 1150 115 Co
105,0	120,0	9,0	10,0	6,0	RSB 1050 1200 090 Co
105,0	120,0	10,0	11,0	6,0	RSB 1050 1200 100 Co
105,0	125,0	12,0	13,0	7,0	RSB 1050 1250 120 Co
106,0	121,0	9,0	10,0	6,0	RSB 1060 1210 090 Co
106,0	121,0	10,0	11,0	6,0	RSB 1060 1210 100 Co
110,0	118,0	11,5	12,5	5,0	RSB 1100 1180 115 Co
110,0	125,0	9,0	10,0	6,0	RSB 1100 1250 090 Co
110,0	125,0	9,6	10,6	6,0	RSB 1100 1250 096 Co
110,0	125,0	10,0	11,0	6,0	RSB 1100 1250 100 Co
110,0	130,0	10,0	11,0	7,0	RSB 1100 1300 100 Co
110,0	130,0	12,0	13,0	7,0	RSB 1100 1300 120 Co
110,0	130,0	15,0	16,0	7,0	RSB 1100 1300 150 Co
110,0	135,0	19,0	20,0	8,0	RSB 1100 1350 190 Co
112,0	127,0	9,0	10,0	6,0	RSB 1120 1270 090 Co
112,0	127,0	10,0	11,0	6,0	RSB 1120 1270 100 Co
112,0	125,0	9,0	10,0	5,5	RSB 1120 1250 090 Co
115,0	123,0	11,5	12,5	5,0	RSB 1150 1230 115 Co
115,0	125,0	12,0	13,0	5,5	RSB 1150 1250 120 Co
115,0	130,0	9,0	10,0	6,0	RSB 1150 1300 090 Co
115,0	135,0	12,0	13,0	7,0	RSB 1150 1350 120 Co
118,0	126,0	11,5	12,5	5,0	RSB 1180 1260 115 Co
118,0	133,0	9,0	10,0	6,0	RSB 1180 1330 090 Co
118,0	133,0	10,0	11,0	6,0	RSB 1180 1330 100 Co
120,0	128,0	11,5	12,5	5,0	RSB 1200 1280 115 Co
120,0	135,0	9,0	10,0	6,0	RSB 1200 1350 090 Co
120,0	140,0	10,0	11,0	7,0	RSB 1200 1400 100 Co
120,0	140,0	12,0	13,0	7,0	RSB 1200 1400 120 Co
120,0	140,0	15,0	16,0	7,0	RSB 1200 1400 150 Co

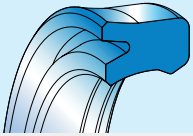

RSB

d _{hg}	D _{H10}	h	E _{+0,2}	C	ART / ITEM
125,0	133,0	11,5	12,5	5,0	RSB 1250 1330 115 Co
125,0	140,0	9,0	10,0	6,0	RSB 1250 1400 090 Co
125,0	145,0	12,0	13,0	7,0	RSB 1250 1450 120 Co
125,0	145,0	15,0	16,0	7,0	RSB 1250 1450 150 Co
125,0	150,0	19,0	20,0	8,0	RSB 1250 1500 190 Co
128,0	136,0	11,5	12,5	5,0	RSB 1280 1360 115 Co
130,0	145,0	9,0	10,0	6,0	RSB 1300 1450 090 Co
130,0	150,0	12,0	13,0	7,0	RSB 1300 1500 120 Co
130,0	150,0	15,0	16,0	7,0	RSB 1300 1500 150 Co
135,0	143,0	11,5	12,5	5,0	RSB 1350 1430 115 Co
140,0	148,0	11,5	12,5	5,0	RSB 1400 1480 115 Co
140,0	155,0	9,0	10,0	6,0	RSB 1400 1550 090 Co
140,0	155,0	9,6	10,6	6,0	RSB 1400 1550 096 Co
140,0	155,0	10,0	11,0	6,0	RSB 1400 1550 100 Co
140,0	160,0	15,0	16,0	7,0	RSB 1400 1600 150 Co
140,0	165,0	19,0	20,0	8,0	RSB 1400 1650 190 Co
143,0	151,0	11,5	12,5	5,0	RSB 1430 1510 115 Co
150,0	165,0	9,0	10,0	6,0	RSB 1500 1650 090 Co
150,0	170,0	12,0	13,0	7,0	RSB 1500 1700 120 Co
150,0	170,0	15,0	16,0	7,0	RSB 1500 1700 150 Co
152,0	160,0	11,5	12,5	5,0	RSB 1520 1600 115 Co
155,0	163,0	11,5	12,5	5,0	RSB 1550 1630 115 Co
160,0	168,0	11,5	12,5	5,0	RSB 1600 1680 115 Co
170,0	180,0	12,0	13,0	5,0	RSB 1700 1800 120 Co
170,0	190,0	15,0	16,0	7,0	RSB 1700 1900 150 Co
180,0	200,0	15,0	16,0	7,0	RSB 1800 2000 150 Co
180,0	205,0	15,0	16,0	8,0	RSB 1800 2050 150 Co
200,0	225,0	15,0	16,0	8,0	RSB 2000 2250 150 Co

Nota: altre dimensioni non a catalogo a richiesta. Consultare il nostro ufficio tecnico.

Remark: please contact our technical dept. for further dimensions not included in the catalogue.



Index

Rod Seals

Piston Seals

Wipers

Wear Rings

Static Seals

Materials



ARTIC SEALS™

RSB

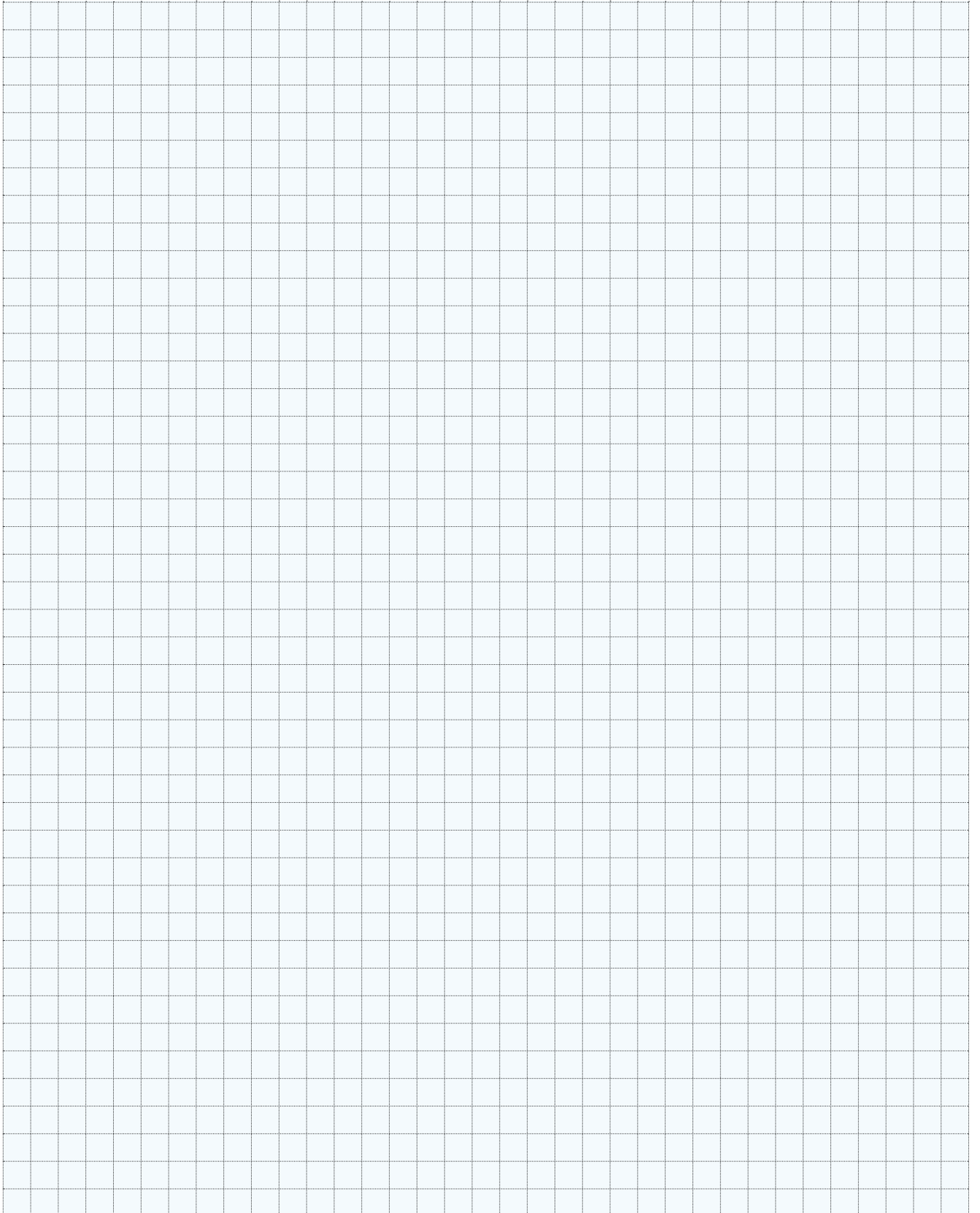
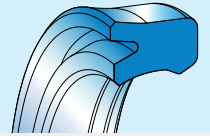

Oleodinamica
Hydraulic

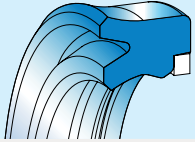

RSB2

TENUTA STELO TIPO RSB2

Descrizione

La tenuta stelo RSB2 è molto simile alla tenuta RSB con l'aggiunta di un anello antiestrusione. Si utilizza questa tenuta quando non è possibile ridurre i giochi di accoppiamento tra la testata e lo stelo e dove esistono picchi di pressione elevata.

Dati tecnici

Pressione: <400 bar con punte a 500 bar alla temperatura di 60°C

Velocità: <0.5 m/s

Temperatura: da -35°C a +100°C con punte fino a +110°C

Fluidi: fluidi idraulici a base minerale (v. tabella 3 a p. 14)

Materiale

Il materiale proposto è il poliuretano tipo Co ad alto modulo elastico, basso compression-set ed elevata resistenza all'abrasione. Ha una durezza di 93 Shore A±2.

Per l'anello antiestrusione è proposta una resina poliacetalica (Ro) con elevata resistenza al carico di rottura.

Codice materiale: CR

Montaggio

Eliminare bave e spigoli taglienti presenti nella sede e sullo stelo per evitare che la guarnizione si danneggi. È sempre consigliato lubrificare la tenuta prima del montaggio per agevolare l'inserimento dello stelo. Per ulteriori informazioni leggere le istruzioni a p. 63.

RSB2 TYPE ROD SEAL

Description

The RSB2 seal type is similar to the RSB type with anti-extrusion ring. This seal is recommended when the coupling clearance between the head and the rod cannot be reduced and in the event of high pressure peaks.

Technical data

Pressure: <400 bar with peaks till 500 bar At 60°C

Speed: < 0.5 [m/s]

Temperature: -35 °C ÷ +100 °C with peaks till +110°C

Fluids: mineral hydraulic fluids (see table 3, page 14)

Material

The proposed material is a "Co" type polyurethane, with high elasticity modulus, low compression-set and high abrasion resistance.

The hardness is 93 Shore A ± 2.

The material proposed for the antiextrusion ring is polyacetal resin (Ro) with haight resintence to breaking load

Material code:CR

Assembling

To prevent any damage to the seal, remove any flash and cutting edges in the housing and on the rod.

The seal should always be lubricated before assembling in order to have easier insertion of the rod.

For further information please refer to the installation instructions on page 63.



RSB2

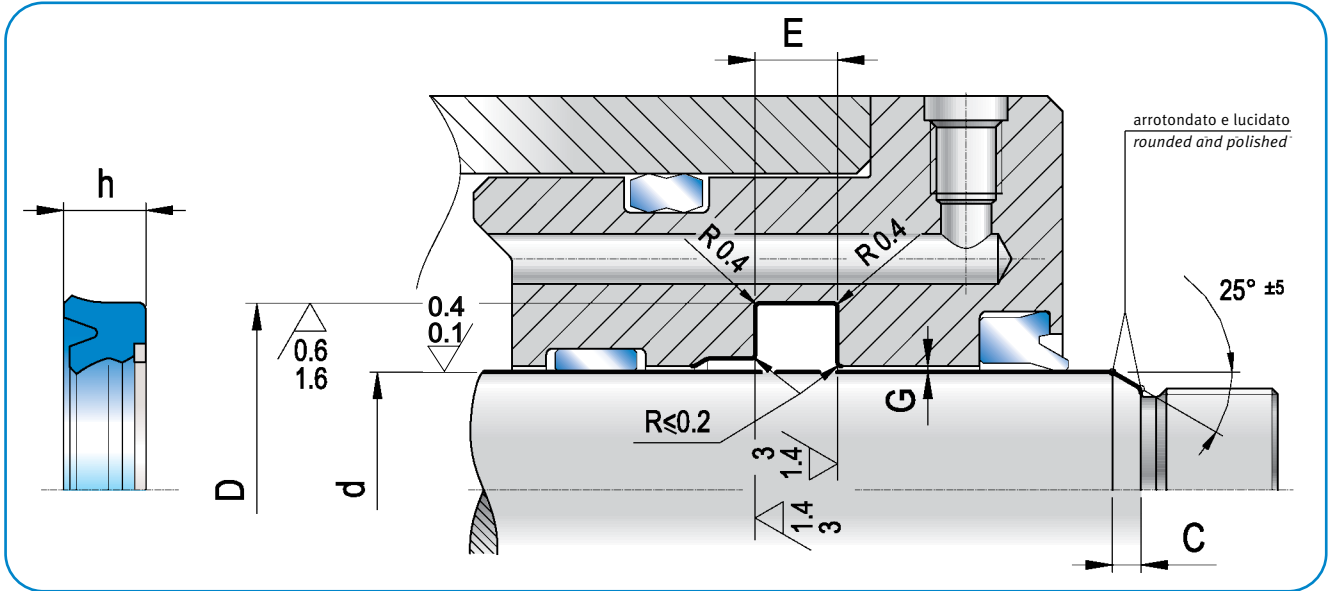
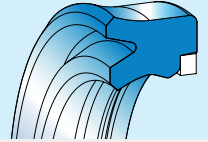

dh9	DH10	h	E _{+0,2}	C	ART / ITEM
40,0	55,0	10,0	11,0	5,5	RSB2 0400 0550 100 CR
42,0	51,0	10,0	11,0	4,5	RSB2 0420 0510 100 CR
45,0	60,0	10,0	11,0	5,5	RSB2 0450 0600 100 CR
50,0	59,0	10,0	11,0	4,5	RSB2 0500 0590 100 CR
50,0	60,0	7,3	8,0	5,0	RSB2 0500 0600 073 CR
50,0	65,0	10,0	11,0	5,5	RSB2 0500 0650 100 CR
50,0	65,0	11,5	12,5	5,5	RSB2 0500 0650 115 CR
50,0	70,0	12,0	13,0	6,0	RSB2 0500 0700 120 CR
56,0	71,0	11,5	12,5	5,5	RSB2 0560 0710 115 CR
60,0	69,0	10,0	11,0	4,5	RSB2 0600 0690 100 CR
60,0	75,0	11,5	12,5	5,5	RSB2 0600 0750 115 CR
60,0	80,0	12,0	13,0	6,0	RSB2 0600 0800 120 CR
63,0	78,0	11,5	12,5	5,5	RSB2 0630 0780 115 CR
63,0	83,0	12,0	13,0	6,0	RSB2 0630 0830 120 CR
65,0	80,0	11,5	12,5	5,5	RSB2 0650 0800 115 CR
70,0	80,0	7,3	8,0	5,0	RSB2 0700 0800 073 CR
70,0	85,0	11,5	12,5	5,5	RSB2 0700 0850 115 CR
75,0	95,0	13,5	14,5	6,0	RSB2 0750 0950 135 CR

dh9	DH10	h	E _{+0,2}	C	ART / ITEM
80,0	95,0	11,5	12,5	5,5	RSB2 0800 0950 115 CR
80,0	100,0	13,5	14,5	7,0	RSB2 0800 1000 135 CR
85,0	100,0	11,0	12,0	7,0	RSB2 0850 1000 110 CR
85,0	105,0	12,0	13,0	7,0	RSB2 0850 1050 120 CR
85,0	105,0	13,5	14,5	7,0	RSB2 0850 1050 135 CR
90,0	105,0	11,5	12,5	6,0	RSB2 0900 1050 115 CR
95,0	115,0	13,5	14,5	7,0	RSB2 0950 1150 135 CR
100,0	120,0	12,0	13,0	7,0	RSB2 1000 1200 120 CR
100,0	120,0	13,5	14,5	7,0	RSB2 1000 1200 135 CR
105,0	120,0	13,0	14,0	7,0	RSB2 1050 1250 120 CR
105,0	125,0	12,0	13,0	7,0	RSB2 1050 1250 120 CR
110,0	125,0	11,0	12,0	7,0	RSB2 1100 1250 110 CR
110,0	130,0	12,0	13,0	7,0	RSB2 1100 1300 120 CR
120,0	140,0	12,0	13,0	7,0	RSB2 1200 1400 120 CR
125,0	145,0	12,0	13,0	7,0	RSB2 1250 1450 120 CR
130,0	150,0	12,0	13,0	7,0	RSB2 1300 1500 120 CR

CR = CO (TPU 93 shore A) + RO (POM)

Nota: altre dimensioni non a catalogo a richiesta. Consultare il nostro ufficio tecnico.

Remark: please contact our technical dept. for further dimensions not included in the catalogue.



BLF®

TENUTA STELO TIPO BLF®

Descrizione

La tenuta stelo BLF® riduce significativamente sia la temperatura di funzionamento della tenuta che il rischio di estrusione successivo, grazie al suo profilo unico e innovativo.

Le protrusioni presenti sulla superficie di scorrimento interna della guarnizione diminuisce l'area di contatto, riducendo a sua volta l'attrito e spostando la base della guarnizione al di fuori del gioco di accoppiamento, riducendo al minimo il rischio di estrusione. L'aggiunta del canale davanti al labbro di tenuta primario, non solo riduce l'area di contatto, ma consente inoltre di catturare l'olio all'interno della superficie di scorrimento, creando una camera d'olio per lubrificare il labbro di tenuta.

Dati tecnici

Pressione: <400 bar con punte a 500 bar alla temperatura di 60°C
 Velocità: <0.5 m/s
 Temperatura: da - 35°C a +100°C con punte fino a +110°C
 Fluidi : fluidi idraulici a base minerale (v. tabella 3 a p. 14)

Materiale

Il materiale proposto è il poliuretano tipo Co ad alto modulo elastico, basso compression-set ed elevata resistenza all'abrasione.
 Ha una durezza di 93 Shore A±2.

Montaggio

Eliminare bave e spigoli taglienti presenti nella sede e sullo stelo per evitare che la guarnizione si danneggi. È sempre consigliato lubrificare la tenuta prima del montaggio per agevolare l'inserimento dello stelo.

BLF® TYPE ROD SEAL

Description

The BLF® seal Type significantly reduces both the operating temperature of the seal and subsequent extrusion risk, due to its unique and innovative profile.

The feature present on the internal sliding face of the seal decreases the contact area, in turn reducing friction and removing the base of the seal from the clearance gap minimising extrusion risk.

The addition of the channel feature not only reduces the contact area, but also allows oil to be captured within the sliding surface in front of the primary sealing lip, creating an oil chamber to lubricate the sealing lip allowing for smooth linear action.

Technical data

Pressure: <400 bar with peaks until 500 bar At 60°C
 Speed : < 0.5 [m/s]
 Temperature: - 35 °C ÷ +100 °C with peaks until +110°C
 Fluids : mineral based hydraulic fluids (see table 3, page 14)

Material

The proposed material is a "Co" type polyurethane, with high elasticity modulus, low compression-set and high abrasion resistance.
 The hardness is 93 Shore A ± 2.

Assembling

To prevent any damage to the seal during assembly, remove all swarf and sharp edges within the housing and corresponding rod. The seal should always be lubricated before assembling in order to have easier insertion of the rod.

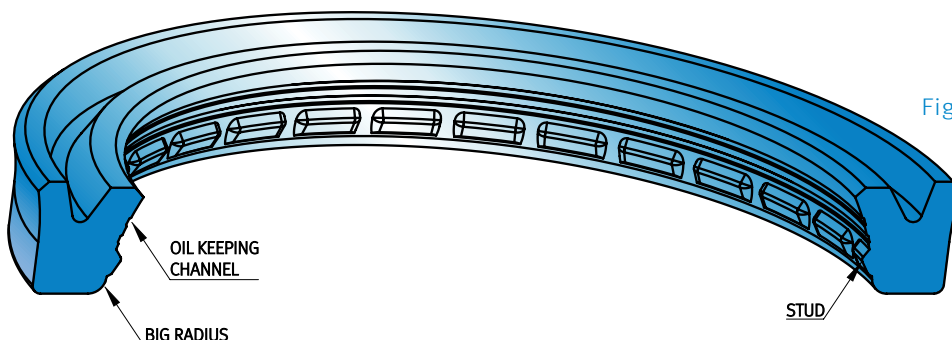
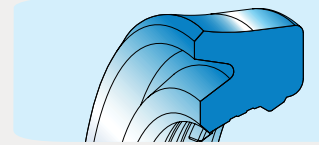

Fig. 27 - Pic.27:



BLF®



NO ANELLO ANTIESTRUSIONE

Grazie al suo profilo unico, BLF® elimina la necessità di un anello antiestrusione aggiuntivo. Una combinazione della larghezza ridotta della base, delle protrusioni interne e di un raggio elevato assicura che il materiale si trovi sempre al di fuori del gioco di accoppiamento delle sedi.

NO BACKUP RING

Due to its unique profile, BLF® eliminates the need for an additional anti-extrusion component. A combination of the reduced base width, stud features and large radius, ensures the base material is not located near the housing clearance gap, thus significantly reducing the risk of extrusion.



Fig. 28 - Pic.28: BLF® montaggio/ BLF® installation

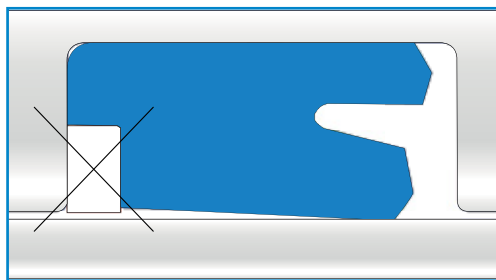
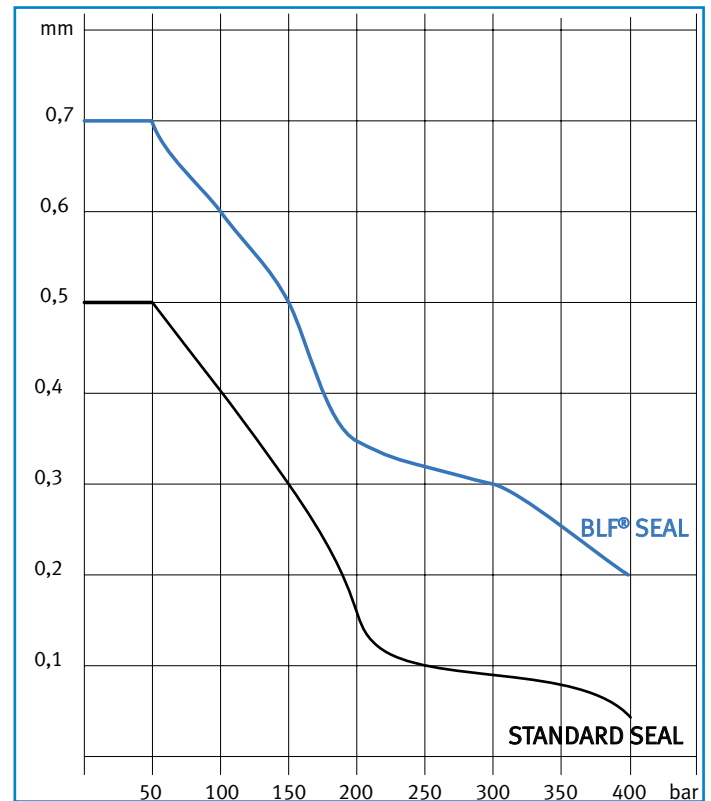
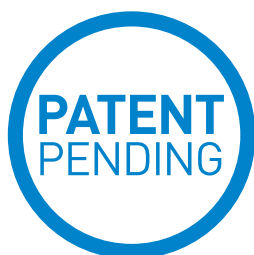

Fig. 29 - Pic.29: Tenuta STD montaggio/STD seal installation

Fig. 30 - Pic.30: PRESSURE / COUPLING CLEARANCE



Oleodinamica
Hydraulic



Tab. 33 - gioco di accoppiamento radiale / radial coupling clearance

PRESSIONE / PRESSURE bar	BLF®SEAL mm	STD SEAL mm
50	0,70	0,50
100	0,60	0,40
150	0,50	0,30
200	0,35	0,15
300	0,30	0,10
400	0,20	0,05



BLF®

BASSO ATTRITO

Una superficie di contatto ridotta, anche quando la guarnizione è soggetta a pressione, riduce significativamente l'attrito sviluppato dalla tenuta durante il funzionamento. Inoltre, la camera di olio creata dal canale assicura che il labbro di tenuta sia lubrificato in modo permanente per un funzionamento regolare e un attrito inferiore.

LOW FRICTION

A reduced contact surface, even when the seal is subject to pressure, significantly reduces the friction developed by the seal during operation. Furthermore, the oil gap created by the channel features, ensures the sealing lip is permanently lubricated for smooth operation and lower friction

Fig. 31 - Pic.31: PRESSURE / OPERATING FRICTION

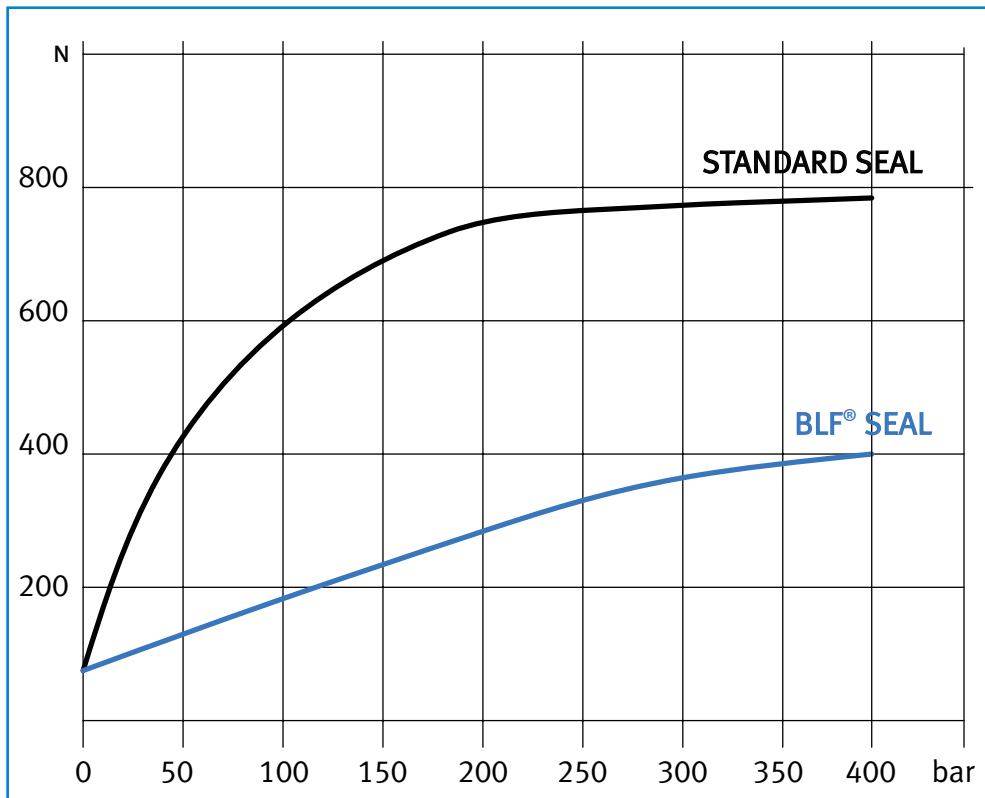

Ampi test mostrano una riduzione dell'attrito operativo di circa un 50% misurato in un intervallo di pressione da 0 a 400 [Bar]

Extensive test shows a reduction in operational friction approximately 50% measured in a pressure range from 0 to 400[Bar]

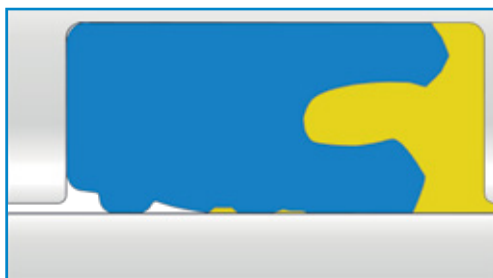

Fig. 32 - Pic.32: BLF® in pressione 400 [Bar]/ BLF® in pressure 400[Bar]

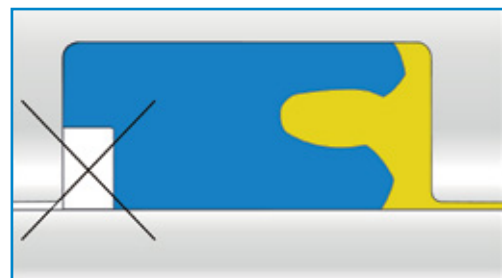
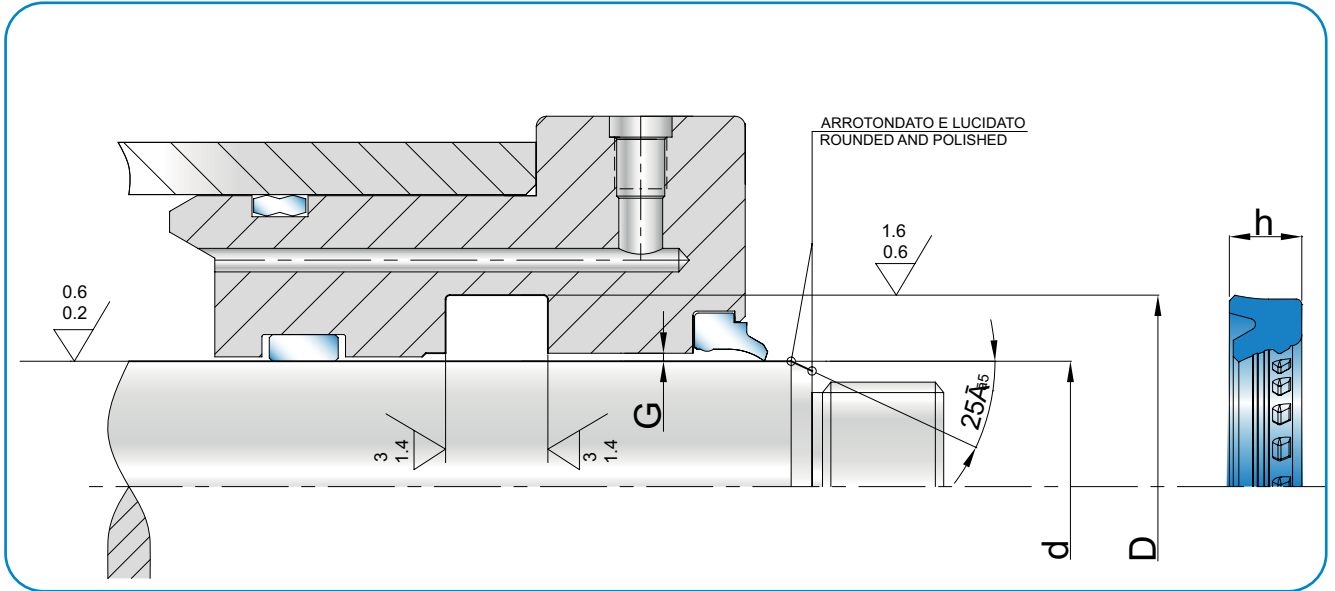
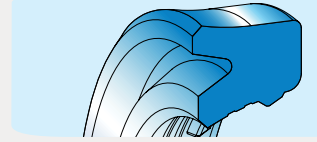

Fig. 33 - Pic.33: Tenuta STD in pressione 400[Bar]/ STD seal in pressure 400 [Bar]



BLF®



dh ₉	D _{H10}	h	E _{+0,2}	C	ART / ITEM
32,0	42,0	7,3	8,0	4,5	BLF 0320 0420 073 Co
40,0	55,0	10,0	11,0	5,5	BLF 0400 0550 100 Co
42,0	51,0	10,0	11,0	4,5	BLF 0420 0510 100 Co
45,0	53,0	5,7	6,3	4,5	BLF 0450 0530 057 Co
45,0	60,0	10,0	11,0	5,5	BLF 0450 0600 100 Co
50,0	59,0	10,0	11,0	4,5	BLF 0500 0590 100 Co
50,0	60,0	7,3	8,0	5,0	BLF 0500 0600 073 Co
50,0	65,0	10,0	11,0	5,5	BLF 0500 0650 100 Co
50,0	65,0	11,5	12,5	5,5	BLF 0500 0650 115 Co
50,0	70,0	12,0	13,0	6,0	BLF 0500 0700 120 Co
56,0	71,0	11,5	12,5	5,5	BLF 0560 0710 115 Co
60,0	69,0	10,0	11,0	4,5	BLF 0600 0690 100 Co
60,0	75,0	11,5	12,5	5,5	BLF 0600 0750 115 Co
60,0	80,0	12,0	13,0	6,0	BLF 0600 0800 120 Co
63,0	78,0	11,5	12,5	5,5	BLF 0630 0780 115 Co
63,0	83,0	12,0	13,0	6,0	BLF 0630 0830 120 Co
65,0	80,0	11,5	12,5	5,5	BLF 0650 0800 115 Co
70,0	80,0	7,3	8,0	5,0	BLF 0700 0800 073 Co
70,0	85,0	11,5	12,5	5,5	BLF 0700 0850 115 Co
75,0	95,0	13,5	14,5	6,0	BLF 0750 0950 135 Co
80,0	95,0	11,5	12,5	5,5	BLF 0800 0950 115 Co

dh ₉	D _{H10}	h	E _{+0,2}	C	ART / ITEM
80,0	100,0	13,5	14,5	7,0	BLF 0800 1000 135 Co
85,0	95,0	10,0	11,0	5,5	BLF 0850 0950 100 Co
85,0	100,0	11,0	12,0	7,0	BLF 0850 1000 110 Co
85,0	105,0	12,0	13,0	7,0	BLF 0850 1050 120 Co
85,0	105,0	13,5	14,5	7,0	BLF 0850 1050 135 Co
90,0	105,0	11,5	12,5	6,0	BLF 0900 1050 115 Co
95,0	105,0	10,0	11,0	6,0	BLF 0950 1050 100 Co
95,0	115,0	13,5	14,5	7,0	BLF 0950 1150 135 Co
100,0	120,0	12,0	13,0	7,0	BLF 1000 1200 120 Co
100,0	120,0	13,5	14,5	7,0	BLF 1000 1200 135 Co
105,0	120,0	13,0	14,0	7,0	BLF 1050 1200 130 Co
105,0	125,0	12,0	13,0	7,0	BLF 1050 1250 120 Co
110,0	125,0	11,0	12,0	7,0	BLF 1100 1250 110 Co
110,0	130,0	12,0	13,0	7,0	BLF 1100 1300 120 Co
120,0	140,0	12,0	13,0	7,0	BLF 1200 1400 120 Co
120,0	140,0	13,0	14,0	7,0	BLF 1200 1400 130 Co
125,0	145,0	12,0	13,0	7,0	BLF 1250 1450 120 Co
130,0	150,0	12,0	13,0	7,0	BLF 1300 1500 120 Co

Nota: altre dimensioni non a catalogo a richiesta. Consultare il nostro ufficio tecnico.

Remark: please contact our technical dept. for further dimensions not included in the catalogue.

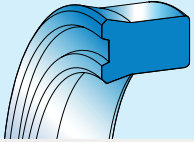

RSC

TENUTA STELO TIPO RSC

Descrizione

La guarnizione tipo RSC è realizzata con ingombri limitati e per cilindri che presentano variazioni di pressione e velocità elevate. Il profilo, progettato con una gola poco profonda, garantisce un forte contatto tra parti statiche e parti dinamiche anche in assenza di pressione.

Dati tecnici

Pressione: < 400 bar a temperatura di 60° C
 Velocità: < 0.5 m/s
 Temperatura: da - 35° C a + 100° C con punte fino a 110° C
 Fluidi: fluidi e oli minerali
 (v. tabella 3 a p. 14)

Materiale

Il materiale proposto è il poliuretano tipo Co ad alto modulo elastico, basso compression-set, alta resistenza all'abrasione.
 Ha una durezza di 93 Shore A ± 2.
 Codice materiale: Co

Montaggio

Eliminare bave e spigoli taglienti nella sede e sullo stelo per evitare che le guarnizioni si danneggino durante il montaggio.
 È consigliabile lubrificare la tenuta durante il montaggio per agevolare l'inserimento dello stelo.
 Per ulteriori informazioni leggere le istruzioni a p. 63.

RSC TYPE ROD SEAL

Description

The RSC seal has small dimensions and has been developed for cylinders used in presence of pressure variation and high speed.
 The profile has been designed with a shallow groove to ensure tight contact between the static and dynamic part, even in zero pressure situations.

Technical data

Pressure: < 400 bar at a temperature of 60° C
 Speed: < 0.5 m/s
 Temperature: from - 35° C to + 100° C, with peaks till 110° C
 Fluids: mineral oils and fluids
 (see table 3, page 14)

Material

The proposed material is a "Co" type polyurethane, with high elasticity modulus, low compression-set and high abrasion resistance.
 The hardness is 93 Shore A ± 2.
 Compound reference: Co

Assembling

To prevent and damage to the seal, remove any flash and cutting edges in the housing and on the rod.
 The seal should always be lubricated before assembling in order to have easier insertion of the rod.
 For further information please refer to the installation instructions on page 63.



RSC

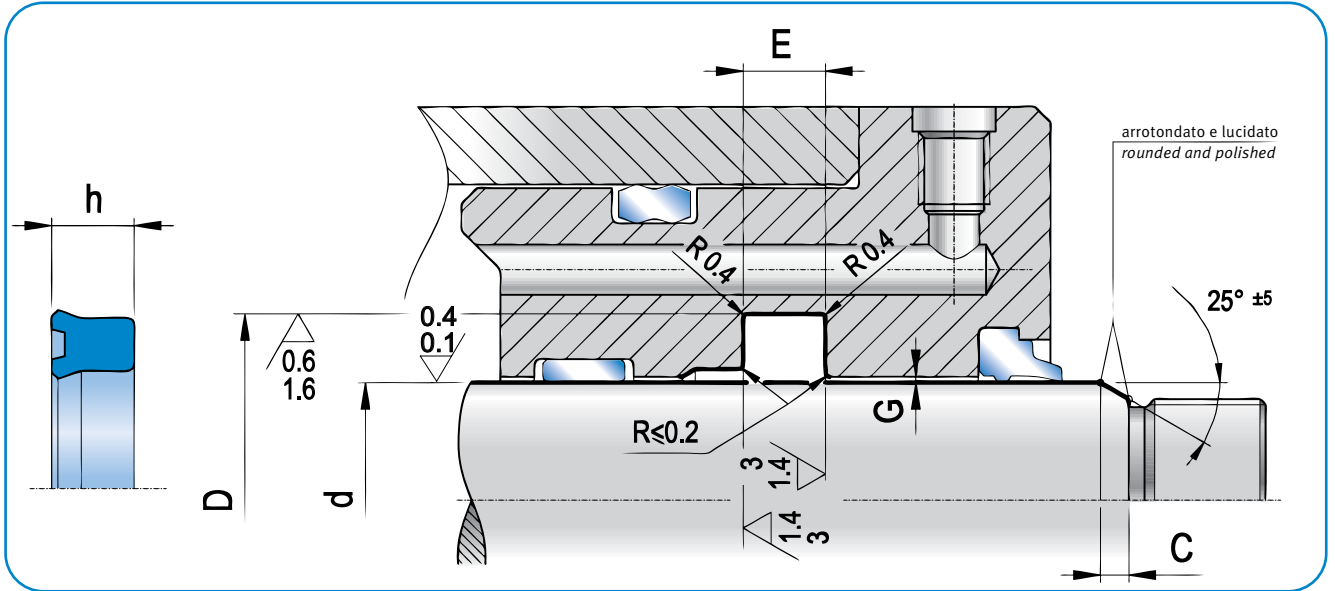
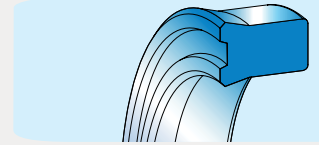

d _{h9}	D _{H10}	h	E _{+0,2}	C	ART / ITEM	
6,0	14,0	5,8	6,3	4,5	RSC 0060 0140 058 Co	
8,0	14,0	5,8	6,3	4,0	RSC 0080 0140 058 Co	
8,0	16,0	5,8	6,3	4,5	RSC 0080 0160 058 Co	
10,0	18,0	5,8	6,3	4,5	RSC 0100 0180 058 Co	
12,0	17,0	3,5	4,0	4,0	RSC 0120 0170 035 Co	
12,0	18,0	4,5	5,0	4,0	RSC 0120 0180 045 Co	
12,0	20,0	5,8	6,3	4,5	RSC 0120 0200 058 Co	
14,0	19,0	3,8	4,5	4,0	RSC 0140 0190 038 Co	
14,0	21,0	5,0	5,5	4,0	RSC 0140 0210 050 Co	
14,0	22,0	5,8	6,3	4,5	RSC 0140 0220 058 Co	
16,0	22,0	4,0	4,5	3,5	RSC 0160 0220 040 Co	
16,0	24,0	5,8	6,3	4,5	RSC 0160 0240 058 Co	
16,0	24,0	6,0	7,0	4,5	RSC 0160 0240 060 Co	
18,0	22,0	4,0	4,5	3,0	RSC 0180 0220 040 Co	
18,0	26,0	5,8	6,3	4,5	RSC 0180 0260 040 Co	
20,0	25,0	4,0	4,5	4,0	RSC 0200 0250 040 Co	
20,0	26,0	5,0	5,5	4,0	RSC 0200 0260 050 Co	
*	20,0	28,0	5,8	6,3	4,5	RSC 0200 0280 058 Co
*	20,0	30,0	7,0	8,0	5,0	RSC 0200 0300 070 Co
22,0	28,0	4,5	5,0	4,0	RSC 0220 0280 045 Co	
22,0	28,0	5,8	6,3	3,5	RSC 0220 0280 058 Co	

d _{h9}	D _{H10}	h	E _{+0,2}	C	ART / ITEM	
22,0	29,0	5,0	5,5	4,0	RSC 0220 0290 050 Co	
*	22,0	30,0	5,8	6,3	4,5	RSC 0220 0300 058 Co
22,0	30,0	7,0	8,0	4,5	RSC 0220 0300 070 Co	
22,0	32,0	7,0	8,0	5,0	RSC 0220 0320 070 Co	
24,0	32,0	5,7	6,3	4,5	RSC 0240 0320 057 Co	
24,0	34,0	5,7	6,3	4,5	RSC 0240 0340 057 Co	
25,0	31,0	5,0	5,5	3,5	RSC 0250 0310 050 Co	
*	25,0	33,0	5,8	6,3	4,5	RSC 0250 0330 058 Co
25,0	33,0	8,0	9,0	4,5	RSC 0250 0330 080 Co	
25,0	35,0	5,0	5,5	5,0	RSC 0250 0350 050 Co	
25,0	35,0	7,0	8,0	5,0	RSC 0250 0350 070 Co	
*	28,0	36,0	5,8	6,3	4,5	RSC 0280 0360 058 Co
28,0	36,0	8,0	9,0	4,5	RSC 0280 0360 080 Co	
28,0	38,0	5,8	6,3	5,0	RSC 0280 0380 058 Co	
28,0	38,0	7,0	8,0	5,0	RSC 0280 0380 070 Co	
30,0	38,0	5,8	6,3	4,5	RSC 0300 0380 058 Co	
30,0	38,0	6,0	7,0	4,5	RSC 0300 0380 060 Co	
30,0	38,0	7,0	8,0	4,5	RSC 0300 0380 070 Co	
30,0	38,0	8,0	9,0	4,5	RSC 0300 0380 080 Co	
30,0	40,0	7,0	8,0	5,0	RSC 0300 0400 070 Co	
30,0	40,0	10,0	11,0	5,0	RSC 0300 0400 100 Co	

* in conformità alle norme ISO/DIN 5597 e ISO 5597/1 – in accordance with ISO/DIN 5597 and ISO 5597/1 norms

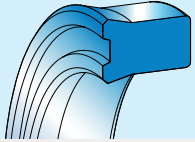

RSC

d _{h9}	D _{H10}	h	E _{+0,2}	C	ART / ITEM
32,0	40,0	6,0	7,0	4,5	RSC 0320 0400 060 Co
32,0	40,0	8,0	9,0	4,5	RSC 0320 0400 080 Co
*	32,0	42,0	7,0	8,0	RSC 0320 0420 070 Co
32,0	42,0	8,0	9,0	5,0	RSC 0320 0420 080 Co
32,0	42,0	9,0	10,0	5,0	RSC 0320 0420 090 Co
35,0	43,0	5,8	6,3	4,5	RSC 0350 0430 058 Co
35,0	43,0	6,0	7,0	4,5	RSC 0350 0430 060 Co
35,0	43,0	6,3	7,0	4,5	RSC 0350 0430 063 Co
35,0	43,0	7,0	8,0	4,5	RSC 0350 0430 070 Co
35,0	43,0	8,0	9,0	4,5	RSC 0350 0430 080 Co
35,0	45,0	7,0	8,0	5,0	RSC 0350 0450 070 Co
35,0	45,0	10,0	11,0	5,0	RSC 0350 0450 100 Co
35,0	45,0	11,0	12,0	5,0	RSC 0350 0450 110 Co
*	36,0	44,0	5,8	6,3	RSC 0360 0440 058 Co
36,0	44,0	6,0	7,0	4,5	RSC 0360 0440 060 Co
36,0	44,0	6,3	7,0	4,5	RSC 0360 0440 063 Co
36,0	44,0	7,0	8,0	4,5	RSC 0360 0440 070 Co
36,0	44,0	8,0	9,0	4,5	RSC 0360 0440 080 Co
36,0	44,0	9,0	10,0	4,5	RSC 0360 0440 090 Co
36,0	46,0	7,0	8,0	5,0	RSC 0360 0460 070 Co
36,0	46,0	7,2	8,0	4,5	RSC 0360 0460 072 Co
36,0	46,0	10,0	11,0	5,0	RSC 0360 0460 100 Co
36,0	46,0	11,0	12,0	5,0	RSC 0360 0460 110 Co
38,0	45,0	6,0	7,0	4,5	RSC 0380 0450 060 Co
40,0	48,0	5,8	6,3	4,5	RSC 0400 0480 058 Co
40,0	48,0	6,0	7,0	4,5	RSC 0400 0480 060 Co
40,0	48,0	7,0	8,0	4,5	RSC 0400 0480 070 Co
40,0	48,0	8,0	9,0	4,5	RSC 0400 0480 080 Co
40,0	50,0	6,0	7,0	5,0	RSC 0400 0500 060 Co
*	40,0	50,0	7,0	8,0	RSC 0400 0500 070 Co
40,0	50,0	10,0	11,0	5,0	RSC 0400 0500 100 Co
42,0	50,0	6,0	7,0	4,5	RSC 0420 0500 060 Co
42,0	50,0	7,0	8,0	4,5	RSC 0420 0500 070 Co
45,0	53,0	6,0	7,0	4,5	RSC 0450 0530 060 Co
45,0	53,0	6,3	7,0	4,5	RSC 0450 0530 063 Co
45,0	53,0	7,0	8,0	4,5	RSC 0450 0530 070 Co

d _{h9}	D _{H10}	h	E _{+0,2}	C	ART / ITEM	
*	45,0	55,0	5,8	6,3	5,0	RSC 0450 0550 058 Co
45,0	55,0	6,3	7,0	5,0	RSC 0450 0550 063 Co	
*	45,0	55,0	7,0	8,0	5,0	RSC 0450 0550 070 Co
46,0	54,0	7,0	8,0	4,5	RSC 0460 0540 070 Co	
46,0	54,0	7,5	8,5	4,5	RSC 0460 0540 075 Co	
46,0	54,0	8,0	9,0	4,5	RSC 0460 0540 080 Co	
50,0	58,0	8,0	9,0	4,5	RSC 0500 0580 080 Co	
50,0	58,0	9,0	10,0	4,5	RSC 0500 0580 090 Co	
*	50,0	60,0	7,0	8,0	5,0	RSC 0500 0600 070 Co
50,0	60,0	8,0	9,0	5,0	RSC 0500 0600 080 Co	
50,0	60,0	10,0	11,0	5,0	RSC 0500 0600 100 Co	
50,0	60,0	11,0	12,0	5,0	RSC 0500 0600 110 Co	
50,0	62,0	8,0	9,0	5,5	RSC 0500 0620 080 Co	
55,0	63,0	8,0	9,0	4,5	RSC 0550 0630 080 Co	
55,0	65,0	5,0	6,0	5,0	RSC 0550 0650 050 Co	
55,0	65,0	7,0	8,0	5,0	RSC 0550 0650 070 Co	
55,0	65,0	11,0	12,0	5,0	RSC 0550 0650 110 Co	
56,0	66,0	10,0	11,0	5,0	RSC 0560 0660 100 Co	
56,0	66,0	11,0	12,0	5,0	RSC 0560 0660 110 Co	
*	56,0	71,0	11,5	12,5	6,0	RSC 0560 0710 115 Co
56,0	71,0	12,5	13,5	6,0	RSC 0560 0710 125 Co	
60,0	68,0	8,0	9,0	5,0	RSC 0600 0680 080 Co	
60,0	68,0	9,0	10,0	4,5	RSC 0600 0680 090 Co	
60,0	70,0	7,0	8,0	5,5	RSC 0600 0700 070 Co	
60,0	70,0	7,5	8,5	5,5	RSC 0600 0700 075 Co	
60,0	70,0	8,0	9,0	5,0	RSC 0600 0700 080 Co	
60,0	70,0	8,5	9,5	5,0	RSC 0600 0700 085 Co	
60,0	70,0	11,0	12,0	5,0	RSC 0600 0700 110 Co	
60,0	70,0	12,0	13,0	5,5	RSC 0600 0700 120 Co	
60,0	70,0	13,0	14,0	5,0	RSC 0600 0700 130 Co	
60,0	72,0	8,0	9,0	5,5	RSC 0600 0720 080 Co	
60,0	72,0	9,0	10,0	5,5	RSC 0600 0720 090 Co	
63,0	71,0	8,0	9,0	5,0	RSC 0630 0710 080 Co	
65,0	73,0	8,0	9,0	5,0	RSC 0650 0730 080 Co	
65,0	73,0	9,0	10,0	4,5	RSC 0650 0730 090 Co	
65,0	75,0	12,0	13,0	5,0	RSC 0650 0750 120 Co	

* in conformità alle norme ISO/DIN 5597 e ISO 5597/1 – in accordance with ISO/DIN 5597 and ISO 5597/1 norms



RSC

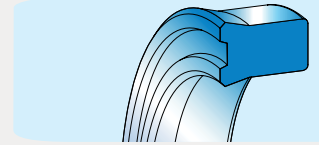

d _{h9}	D _{H10}	h	E _{+0,2}	C	ART / ITEM
70,0	78,0	8,0	9,0	5,0	RSC 0700 0780 080 Co
70,0	78,0	9,0	10,0	4,5	RSC 0700 0780 090 Co
* 70,0	80,0	6,5	7,5	5,5	RSC 0700 0800 065 Co
70,0	80,0	7,0	8,0	5,5	RSC 0700 0800 070 Co
70,0	80,0	7,5	8,5	5,0	RSC 0700 0800 075 Co
70,0	80,0	8,0	9,0	5,0	RSC 0700 0800 080 Co
70,0	80,0	12,0	13,0	5,5	RSC 0700 0800 120 Co
70,0	80,0	13,0	14,0	5,0	RSC 0700 0800 130 Co
70,0	82,0	9,5	10,5	6,0	RSC 0700 0820 095 Co
70,0	82,0	10,5	11,5	6,0	RSC 0700 0820 105 Co
70,0	85,0	11,5	12,5	6,0	RSC 0700 0850 115 Co
70,0	85,0	12,5	13,5	6,5	RSC 0700 0850 125 Co
75,0	83,0	8,0	9,0	5,0	RSC 0750 0830 080 Co
75,0	83,0	9,0	10,0	4,5	RSC 0750 0830 090 Co
75,0	85,0	7,0	8,0	5,5	RSC 0750 0850 070 Co

d _{h9}	D _{H10}	h	E _{+0,2}	C	ART / ITEM
75,0	85,0	8,0	9,0	5,0	RSC 0750 0850 080 Co
76,0	84,0	8,0	9,0	5,0	RSC 0760 0840 080 Co
76,0	84,0	9,0	10,0	4,5	RSC 0760 0840 090 Co
80,0	88,0	8,0	9,0	5,0	RSC 0800 0880 080 Co
80,0	88,0	9,0	10,0	4,5	RSC 0800 0880 090 Co
80,0	90,0	7,0	8,0	5,5	RSC 0800 0900 070 Co
80,0	90,0	8,0	9,0	5,0	RSC 0800 0900 080 Co
80,0	90,0	12,0	13,0	5,0	RSC 0800 0900 120 Co
* 80,0	95,0	11,5	12,5	6,5	RSC 0800 0950 115 Co
80,0	95,0	12,5	13,5	6,5	RSC 0800 0950 125 Co
85,0	93,0	8,0	9,0	5,5	RSC 0850 0930 080 Co
85,0	93,0	9,0	10,0	4,5	RSC 0850 0930 090 Co
90,0	98,0	8,0	9,0	5,5	RSC 0900 0980 080 Co
90,0	98,0	9,0	10,0	4,5	RSC 0900 0980 090 Co

* in conformità alle norme ISO/DIN 5597 e ISO 5597/1 – in accordance with ISO/DIN 5597 and ISO 5597/1 norms

Nota: altre dimensioni non a catalogo a richiesta. Consultare il nostro ufficio tecnico.

Remark: please contact our technical dept. for further dimensions not included in the catalogue.

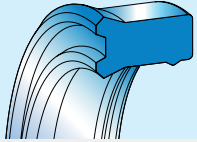

RSD

TENUTA STELO TIPO RSD

Descrizione

La guarnizione tipo RSD è molto simile al tipo RSC ma sul lato dinamico, ossia sul diametro interno, presenta due labbri che hanno più di una funzione:

- attenua eventuali fenomeni di stick-slip grazie al fluido trattenuto nell'intercapedine fra i due labbri
- evita alle impurità di entrare dall'esterno
- contrasta il ritiro del materiale alle basse temperature
- funge da stabilizzatore.

Dati tecnici

Pressione: < 400 bar a temperatura di 60° C

Velocità: < 0.5 m/s

Temperatura: da - 35° C a + 100° C con punte fino a 110° C

Fluidi: fluidi e oli minerali
(v. tabella 3 a p. 14)

Materiale

Il materiale proposto è il poliuretano tipo Co ad alto modulo elastico, basso compression-set, alta resistenza all'abrasione.

Ha una durezza di 93 Shore A ± 2.

Codice materiale: Co

Montaggio

Eliminare bave e spigoli taglienti nella sede e sullo stelo per evitare che le guarnizioni si danneggino durante il montaggio. È consigliabile lubrificare la tenuta durante il montaggio per agevolare l'inserimento dello stelo.

Per ulteriori informazioni leggere le istruzioni a p. 63.

RSD TYPE ROD SEAL

Description

The RSD seal type is similar to the RSC type, but on the dynamic side, it presents a multifunctional double lip which:

- reduces stick-slip effects thanks because it keeps oil between the secondary lip and the main one
- stops any external impurities
- faces the material shrinkage at low temperatures
- acts as a stabilizer.

Technical data

Pressure: < 400 bar at a temperature of 60° C

Speed: < 0.5 m/s

Temperature: from - 35° C to + 100° C with peaks till 110° C

Fluids: mineral fluids and oils
(see table 3, page 14)

Material

The proposed material is a "Co" type polyurethane, with high elasticity modulus, low compression-set and high abrasion resistance.

The hardness is 93 Shore A ± 2.

Compound reference: Co

Assembling

To prevent any damage to the seal, remove any flash and cutting edges in the housing and on the rod. The seal should always be lubricated before assembling in order to have easier insertion of the rod.

For further information please refer to the installation instructions on page 63.



RSD

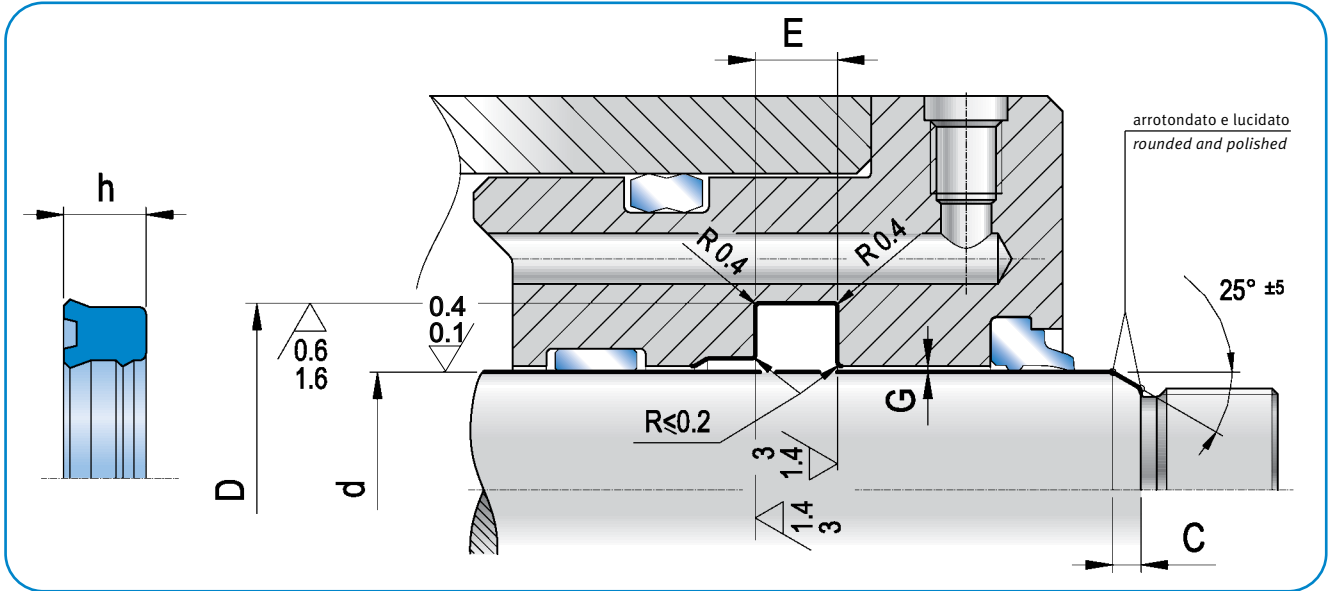
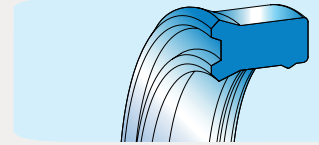

d _{h9}	D _{H10}	h	E _{+0,2}	C	ART / ITEM	
*	6,0	14,0	5,8	6,3	3,5	RSD 0060 0140 058 Co
*	8,0	14,0	5,7	6,3	3,5	RSD 0080 0140 057 Co
*	8,0	16,0	5,8	6,3	3,5	RSD 0080 0160 058 Co
*	10,0	18,0	5,8	6,3	3,5	RSD 0100 0180 058 Co
	11,0	16,0	3,5	4,0	3,5	RSD 0110 0160 035 Co
	12,0	19,0	5,0	5,6	3,5	RSD 0120 0190 050 Co
*	12,0	20,0	5,8	6,3	4,5	RSD 0120 0200 058 Co
	14,0	21,0	5,0	5,6	4,0	RSD 0140 0210 050 Co
	14,0	22,0	5,8	6,3	4,5	RSD 0140 0220 058 Co
	15,0	21,0	4,5	5,0	4,0	RSD 0150 0210 045 Co
	15,0	23,0	5,8	6,3	4,5	RSD 0150 0230 058 Co
	15,0	23,0	6,0	7,0	4,5	RSD 0150 0230 060 Co
	16,0	22,0	5,0	5,6	3,5	RSD 0160 0220 050 Co
*	16,0	24,0	5,8	6,3	4,5	RSD 0160 0240 058 Co
	18,0	22,0	4,0	4,5	3,0	RSD 0180 0220 040 Co
	18,0	24,0	4,7	5,3	4,0	RSD 0180 0240 047 Co
	18,0	25,0	5,0	5,7	4,0	RSD 0180 0250 050 Co
*	18,0	26,0	5,8	6,3	4,5	RSD 0180 0260 058 Co
	18,0	26,0	8,0	9,0	4,5	RSD 0180 0260 080 Co
	20,0	25,0	4,0	4,5	3,5	RSD 0200 0250 040 Co
	20,0	26,0	3,2	4,0	3,5	RSD 0200 0260 032 Co

d _{h9}	D _{H10}	h	E _{+0,2}	C	ART / ITEM	
	20,0	26,0	5,2	6,0	3,5	RSD 0200 0260 052 Co
*	20,0	28,0	5,8	6,3	4,5	RSD 0200 0280 058 Co
*	20,0	30,0	7,0	8,0	5,0	RSD 0200 0300 070 Co
	22,0	28,0	4,5	5,5	3,5	RSD 0220 0280 045 Co
	22,0	28,0	5,8	6,3	3,5	RSD 0220 0280 058 Co
	22,0	29,0	5,0	5,6	4,0	RSD 0220 0290 050 Co
*	22,0	30,0	5,8	6,3	4,5	RSD 0220 0300 058 Co
	24,0	32,0	5,8	6,3	4,5	RSD 0240 0320 058 Co
	25,0	31,0	5,0	5,6	3,5	RSD 0250 0310 050 Co
	25,0	31,0	3,5	4,0	3,5	RSD 0250 0310 035 Co
	25,0	32,0	4,0	4,5	3,5	RSD 0250 0320 040 Co
*	25,0	33,0	5,8	6,3	4,5	RSD 0250 0330 058 Co
	25,0	33,0	6,5	7,5	4,5	RSD 0250 0330 065 Co
	25,0	33,0	7,0	8,0	4,5	RSD 0250 0330 070 Co
	25,0	33,0	8,0	9,0	4,5	RSD 0250 0330 080 Co
*	25,0	35,0	7,0	8,0	5,0	RSD 0250 0350 070 Co
	25,0	35,0	8,0	9,0	5,0	RSD 0250 0350 080 Co
	26,0	34,0	5,8	6,3	5,0	RSD 0260 0340 058 Co
*	28,0	34,0	3,5	4,0	4,5	RSD 0280 0340 035 Co
*	28,0	36,0	5,8	6,3	4,5	RSD 0280 0360 058 Co
*	28,0	38,0	5,8	6,3	5,0	RSD 0280 0380 058 Co

* in conformità alle norme ISO/DIN 5597 e ISO 5597/1 – in accordance with ISO/DIN 5597 and ISO 5597/1 norms

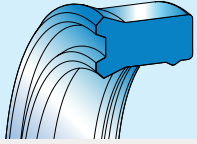

RSD

	d _{h9}	D _{H10}	h	E _{+0,2}	C	ART / ITEM
*	28,0	38,0	7,0	8,0	5,0	RSD 0280 0380 070 Co
	30,0	38,0	5,8	6,3	4,5	RSD 0300 0380 058 Co
	30,0	38,0	7,0	8,0	4,5	RSD 0300 0380 070 Co
	30,0	38,0	8,0	9,0	4,5	RSD 0300 0380 080 Co
	30,0	40,0	6,5	7,5	5,0	RSD 0300 0400 065 Co
	30,0	40,0	10,0	11,0	5,0	RSD 0300 0400 100 Co
	32,0	40,0	5,8	6,3	4,5	RSD 0320 0400 058 Co
	32,0	40,0	6,0	7,0	4,5	RSD 0320 0400 060 Co
	32,0	40,0	8,0	9,0	4,5	RSD 0320 0400 080 Co
*	32,0	42,0	7,0	8,0	4,5	RSD 0320 0420 070 Co
	32,0	42,0	8,0	9,0	5,0	RSD 0320 0420 080 Co
	32,0	42,0	10,0	11,0	5,0	RSD 0320 0420 100 Co
	32,0	45,0	8,0	9,0	7,0	RSD 0320 0450 080 Co
	35,0	43,0	5,8	6,3	4,5	RSD 0350 0430 058 Co
	35,0	43,0	6,0	7,0	4,5	RSD 0350 0430 060 Co
	35,0	43,0	8,0	9,0	4,5	RSD 0350 0430 080 Co
	35,0	45,0	7,0	8,0	5,0	RSD 0350 0450 070 Co
	35,0	45,0	10,0	11,0	5,0	RSD 0350 0450 100 Co
*	36,0	44,0	5,8	6,3	4,5	RSD 0360 0440 058 Co
	36,0	44,0	8,0	9,0	4,5	RSD 0360 0440 080 Co
	40,0	48,0	5,8	6,3	4,5	RSD 0400 0480 058 Co
	40,0	48,0	8,0	9,0	4,5	RSD 0400 0480 080 Co
*	40,0	50,0	7,0	8,0	5,0	RSD 0400 0500 070 Co
	40,0	50,0	10,0	11,0	5,0	RSD 0400 0500 100 Co
	40,0	55,0	10,0	11,0	6,5	RSD 0400 0550 100 Co
	42,0	50,0	6,0	7,0	4,5	RSD 0420 0500 060 Co
	42,0	52,0	8,0	9,0	5,0	RSD 0420 0520 080 Co
	45,0	52,0	12,0	13,0	5,0	RSD 0450 0520 120 Co
*	45,0	53,0	5,8	6,3	4,5	RSD 0450 0530 058 Co
	45,0	53,0	8,0	9,0	4,5	RSD 0450 0530 080 Co
	45,0	53,0	10,0	11,0	4,5	RSD 0450 0530 100 Co
*	45,0	55,0	5,7	6,3	5,0	RSD 0450 0550 057 Co
*	45,0	55,0	7,0	8,0	5,0	RSD 0450 0550 070 Co
	45,0	55,0	10,0	11,0	5,0	RSD 0450 0550 100 Co
	46,0	54,0	8,0	9,0	4,5	RSD 0460 0540 080 Co
	50,0	58,0	8,0	9,0	4,5	RSD 0500 0580 080 Co
	50,0	58,0	11,5	12,5	4,5	RSD 0500 0580 115 Co
*	50,0	60,0	7,0	8,0	5,0	RSD 0500 0600 070 Co
	50,0	60,0	9,0	10,0	5,0	RSD 0500 0600 090 Co

	d _{h9}	D _{H10}	h	E _{+0,2}	C	ART / ITEM
	50,0	60,0	10,0	11,0	5,0	RSD 0500 0600 100 Co
	50,0	65,0	8,0	9,0	6,5	RSD 0500 0650 080 Co
	50,0	65,0	10,0	11,0	6,5	RSD 0500 0650 100 Co
	55,0	63,0	8,0	9,0	4,5	RSD 0550 0630 080 Co
	55,0	65,0	7,0	8,0	5,0	RSD 0550 0650 070 Co
	55,0	65,0	10,0	11,0	5,0	RSD 0550 0650 100 Co
	55,0	65,0	12,0	13,0	5,0	RSD 0550 0650 120 Co
	56,0	64,0	8,0	9,0	4,5	RSD 0560 0640 080 Co
	56,0	66,0	6,5	7,5	5,0	RSD 0560 0660 065 Co
	56,0	66,0	7,3	8,0	5,0	RSD 0560 0660 073 Co
*	56,0	71,0	11,5	12,5	6,5	RSD 0560 0710 115 Co
	60,0	68,0	6,3	7,0	4,5	RSD 0600 0680 063 Co
	60,0	68,0	8,0	9,0	4,5	RSD 0600 0680 080 Co
	60,0	68,0	13,0	14,0	4,5	RSD 0600 0680 130 Co
	60,0	70,0	7,0	8,0	5,5	RSD 0600 0700 070 Co
	60,0	70,0	7,5	8,5	5,5	RSD 0600 0700 075 Co
	60,0	70,0	10,0	11,0	5,5	RSD 0600 0700 100 Co
	60,0	70,0	12,0	13,0	5,5	RSD 0600 0700 120 Co
	60,0	72,0	9,0	10,0	6,0	RSD 0600 0720 090 Co
	61,0	69,0	8,0	9,0	4,5	RSD 0610 0690 080 Co
	63,0	71,0	8,0	9,0	4,5	RSD 0630 0710 080 Co
	65,0	73,0	8,0	9,0	4,5	RSD 0650 0730 080 Co
	65,0	75,0	12,0	13,0	5,0	RSD 0650 0750 120 Co
	65,0	77,0	9,0	10,0	6,0	RSD 0650 0770 090 Co
	65,0	80,0	10,5	11,5	6,0	RSD 0650 0800 105 Co
	68,0	76,0	8,0	9,0	4,5	RSD 0680 0760 080 Co
	70,0	78,0	8,0	9,0	4,5	RSD 0700 0780 080 Co
*	70,0	80,0	6,5	7,5	5,5	RSD 0700 0800 065 Co
	70,0	80,0	7,0	8,0	5,0	RSD 0700 0800 070 Co
	70,0	80,0	12,0	13,0	5,5	RSD 0700 0800 120 Co
	70,0	82,0	9,5	10,5	6,0	RSD 0700 0820 095 Co
*	70,0	85,0	11,5	12,5	6,5	RSD 0700 0850 115 Co
	75,0	83,0	6,3	7,0	4,5	RSD 0750 0830 063 Co
	75,0	83,0	8,0	9,0	4,5	RSD 0750 0830 080 Co
	75,0	85,0	7,0	8,0	5,5	RSD 0750 0850 070 Co
	75,0	85,0	12,0	13,0	5,5	RSD 0750 0850 120 Co
	76,0	84,0	8,0	9,0	4,5	RSD 0760 0840 080 Co
	76,0	86,0	8,0	9,0	5,0	RSD 0760 0860 080 Co
	78,0	86,0	8,0	9,0	4,5	RSD 0780 0860 080 Co

* in conformità alle norme ISO/DIN 5597 e ISO 5597/1 – in accordance with ISO/DIN 5597 and ISO 5597/1 norms



RSD

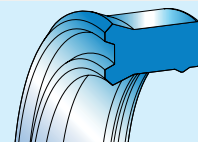

d _{h9}	D _{H10}	h	E _{+0,2}	C	ART / ITEM
78,0	86,0	13,0	14,0	4,5	RSD 0780 0860 130 Co
80,0	88,0	8,0	9,0	4,5	RSD 0800 0880 080 Co
80,0	90,0	12,0	13,0	5,0	RSD 0800 0900 120 Co
80,0	92,0	9,0	10,0	6,0	RSD 0800 0920 090 Co
* 80,0	95,0	11,5	12,5	6,5	RSD 0800 0950 115 Co
85,0	93,0	8,0	9,0	4,5	RSD 0850 0930 080 Co
85,0	95,0	12,0	13,0	5,5	RSD 0850 0950 120 Co
90,0	98,0	6,3	7,0	4,5	RSD 0900 0980 063 Co
90,0	98,0	8,0	9,0	4,5	RSD 0900 0980 080 Co
* 90,0	100,0	6,5	7,5	5,5	RSD 0900 1000 065 Co
* 90,0	105,0	11,5	12,5	6,5	RSD 0900 1050 115 Co
91,0	99,0	8,0	9,0	4,5	RSD 0910 0990 080 Co
95,0	103,0	8,0	9,0	4,5	RSD 0950 1030 080 Co
97,0	105,0	13,0	14,0	4,5	RSD 0970 1050 130 Co
100,0	108,0	6,5	7,5	4,5	RSD 1000 1080 065 Co
100,0	108,0	8,0	9,0	4,5	RSD 1000 1080 080 Co
105,0	113,0	8,0	9,0	4,5	RSD 1050 1130 080 Co
107,0	115,0	8,0	9,0	4,5	RSD 1070 1150 080 Co

d _{h9}	D _{H10}	h	E _{+0,2}	C	ART / ITEM
108,0	116,0	8,0	9,0	4,5	RSD 1080 1160 080 Co
* 110,0	125,0	9,5	10,5	6,5	RSD 1100 1250 095 Co
110,0	125,0	11,0	12,0	6,5	RSD 1100 1250 110 Co
115,0	123,0	8,0	9,0	4,5	RSD 1150 1230 080 Co
115,0	130,0	11,3	12,0	6,5	RSD 1150 1300 113 Co
120,0	128,0	11,5	12,5	4,5	RSD 1200 1280 115 Co
120,0	135,0	15,0	16,0	6,5	RSD 1200 1350 150 Co
125,0	133,0	7,5	8,5	4,5	RSD 1250 1330 075 Co
125,0	133,0	8,0	9,0	4,5	RSD 1250 1330 080 Co
126,0	134,0	8,0	9,0	4,5	RSD 1260 1340 080 Co
130,0	145,0	15,0	16,0	6,5	RSD 1300 1450 150 Co
135,0	143,0	8,0	9,0	4,5	RSD 1350 1430 080 Co
135,0	150,0	11,5	12,5	6,5	RSD 1350 1500 115 Co
140,0	150,0	11,5	12,5	5,0	RSD 1400 1500 115 Co
145,0	153,0	8,0	9,0	4,5	RSD 1450 1530 080 Co

* in conformità alle norme ISO/DIN 5597 e ISO 5597/1 – in accordance with ISO/DIN 5597 and ISO 5597/1 norms

Nota: altre dimensioni non a catalogo a richiesta. Consultare il nostro ufficio tecnico.

Remark: please contact our technical dept. for further dimensions not included in the catalogue.

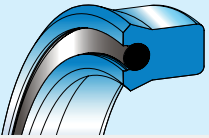

RPO

TENUTA STELO TIPO RPO

Descrizione

La tenuta stelo tipo RPO è caratterizzata dalla presenza di un o-ring, alloggiato nella gola interna tra il labbro dinamico e quello statico, che ha la funzione di energizzare i labbri per garantire la tenuta anche a basse pressioni. Questo profilo garantisce una tenuta perfetta anche in presenza di carichi laterali. L'o-ring può essere fornito in diverse mescole, in base alle temperature di utilizzo.

Dati tecnici

Pressione: < 400 bar a temperatura di 60° C

Velocità: < 0.5 m/s

Temperatura: da - 35° C a + 100° C con punte fino a 110° C

Fluidi: fluidi e oli minerali
(v. tabella 3 a p. 14)

Materiale

Il materiale proposto è il poliuretano tipo Co ad alto modulo elastico, basso compression-set, alta resistenza all'abrasione.

Ha una durezza di 93 Shore A ± 2.

O-Ring standard è proposto in materiale NBR 75 Shore A, in alternativa può essere fornito anche in materiali quali FKM o HNBR

Codice materiale: CN

Montaggio

Il montaggio avviene in cava anulare. Eliminare le bave e gli spigoli taglienti nella sede e sullo stelo per evitare che si danneggino le guarnizioni durante il montaggio. È consigliabile lubrificare la tenuta durante il montaggio per agevolare l'inserimento dello stelo. Per ulteriori informazioni leggere le istruzioni a p. 63.

RPO TYPE ROD SEAL

Description

The rod seal type RPO is characterized by the presence of an O-ring fit in the internal groove between the dynamic lip and the static one, which has the function to energize the sealing lips to ensure the seal even at low pressures. This profile ensures a perfect seal even in the presence of lateral loads. The O-ring can be provided in different compounds, depending on the temperature of use.

Technical data

Pressure: < 400 bar at a temperature of 60° C

Speed: < 0.5 m/s

Temperature: from - 35° C to + 100° C with peaks till 110° C

Fluids: mineral fluids and oils
(see table 3, page 14)

Material

The proposed material is a "Co" type polyurethane, with high elasticity modulus, low compression-set and high abrasion resistance.

The hardness is 93 Shore A ± 2.

Standard O-Ring proposed is in NBR 75 Shore A material, or could be equipped in alternative material like FKM or HNBR

Compound reference: CN

Assembling

To prevent any damage to the seal, remove any flash and cutting edges in the housing and on the rod.

The seal should always be lubricated before assembling in order to have easier insertion of the rod.

For further information please refer to the installation instructions on page 63.



RPO

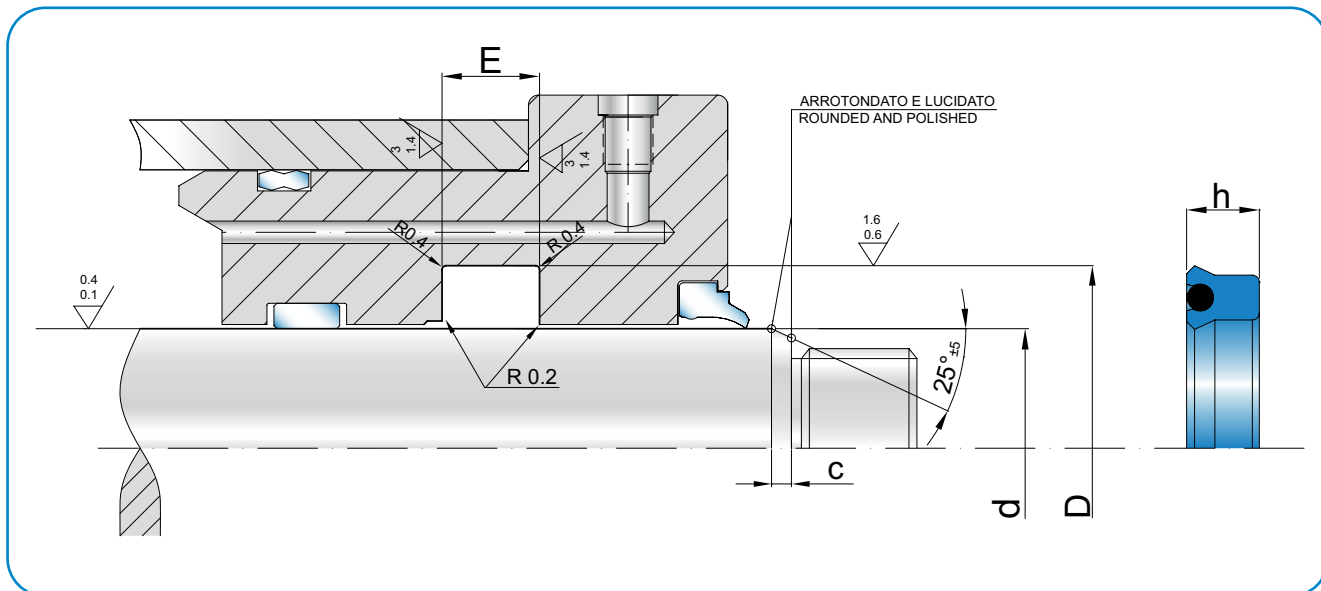
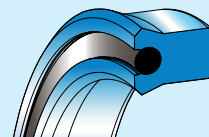

d _{h9}	D _{H10}	h	E _{+0,2}	C	ART / ITEM
9,0	16,0	5,5	6,0	3,5	RPO 0090 0160 055 CN
12,0	20,0	5,0	5,5	3,5	RPO 0120 0200 050 CN
16,0	24,0	5,0	5,5	3,5	RPO 0160 0240 050 CN
20,0	29,0	5,0	5,5	3,5	RPO 0200 0290 050 CN
20,0	30,0	8,0	9,0	3,5	RPO 0200 0300 080 CN
20,0	30,0	10,0	11,0	3,5	RPO 0200 0300 100 CN
22,0	32,0	8,0	9,0	3,5	RPO 0220 0320 080 CN
22,0	32,0	10,0	11,0	3,5	RPO 0220 0320 100 CN
25,0	33,0	6,0	7,0	4,5	RPO 0250 0330 060 CN
25,0	35,0	8,0	9,0	4,5	RPO 0250 0350 080 CN
25,0	35,0	10,0	11,0	4,0	RPO 0250 0350 100 CN
26,0	36,0	7,0	8,0	4,5	RPO 0260 0360 070 CN
28,0	38,0	8,0	9,0	4,5	RPO 0280 0380 080 CN
28,0	38,0	10,0	11,0	4,5	RPO 0280 0380 100 CN
28,0	43,0	11,5	12,0	3,5	RPO 0280 0430 115 CN
30,0	40,0	7,0	8,0	4,5	RPO 0300 0400 070 CN
30,0	40,0	10,0	11,0	3,0	RPO 0300 0400 100 CN
32,0	40,0	8,0	9,0	4,0	RPO 0320 0400 080 CN
32,0	42,0	10,0	11,0	4,5	RPO 0320 0420 100 CN
35,0	45,0	7,0	8,0	4,5	RPO 0350 0450 070 CN
35,0	45,0	8,0	9,0	3,5	RPO 0350 0450 080 CN
35,0	45,0	10,0	11,0	4,5	RPO 0350 0450 100 CN
36,0	46,0	7,2	8,0	4,5	RPO 0360 0450 100 CN
40,0	50,0	7,0	8,0	5,0	RPO 0400 0500 070 CN
40,0	50,0	8,0	9,0	3,5	RPO 0400 0500 080 CN
40,0	50,0	10,0	11,0	3,5	RPO 0400 0500 100 CN
42,0	50,0	6,0	7,0	4,0	RPO 0420 0500 060 CN

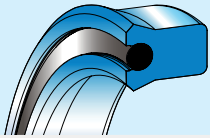

RPO

d_{H9}	D_{H10}	h	$E_{+0,2}$	C	ART / ITEM				
42,0	50,0	8,0	9,0	4,5	RPO	0420	0500	080	CN
45,0	55,0	6,0	7,0	4,5	RPO	0450	0550	060	CN
45,0	55,0	6,5	7,5	3,5	RPO	0450	0550	065	CN
45,0	55,0	8,0	9,0	4,5	RPO	0450	0550	080	CN
45,0	55,0	10,0	11,0	4,5	RPO	0450	0550	100	CN
45,0	60,0	10,0	11,0	4,5	RPO	0450	0600	100	CN
45,0	65,0	11,5	12,5	4,5	RPO	0450	0650	115	CN
50,0	60,0	7,2	8,0	5,0	RPO	0500	0600	072	CN
50,0	60,0	10,0	11,0	5,0	RPO	0500	0600	100	CN
50,0	60,0	11,0	12,0	4,5	RPO	0500	0600	110	CN
50,0	65,0	10,0	11,0	5,0	RPO	0500	0650	100	CN
50,0	65,0	11,5	12,5	5,0	RPO	0500	0650	115	CN
55,0	65,0	10,0	11,0	4,5	RPO	0550	0650	100	CN
55,0	65,0	12,0	13,0	4,5	RPO	0550	0650	120	CN
56,0	71,0	11,5	12,5	4,5	RPO	0560	0710	115	CN
60,0	70,0	8,0	9,0	5,0	RPO	0600	0700	080	CN
60,0	70,0	10,0	11,0	5,0	RPO	0600	0700	100	CN
60,0	70,0	12,0	13,0	4,5	RPO	0600	0700	120	CN
60,0	75,0	11,5	12,5	4,5	RPO	0600	0750	115	CN
63,0	73,0	6,0	7,0	5,0	RPO	0630	0730	060	CN
63,0	73,0	12,0	13,0	5,0	RPO	0630	0730	120	CN
63,0	75,0	10,0	11,0	5,0	RPO	0630	0750	100	CN
65,0	75,0	10,0	11,0	7,0	RPO	0650	0750	100	CN
65,0	75,0	12,0	13,0	4,5	RPO	0650	0750	120	CN
70,0	80,0	8,0	9,0	4,5	RPO	0700	0800	080	CN
70,0	80,0	10,0	11,0	4,5	RPO	0700	0800	100	CN
70,0	80,0	12,0	13,0	5,0	RPO	0700	0800	120	CN
70,0	85,0	11,5	12,5	4,5	RPO	0700	0850	115	CN
70,0	85,0	12,5	13,5	4,5	RPO	0700	0850	125	CN
75,0	85,0	7,0	8,0	4,5	RPO	0750	0850	070	CN
75,0	85,0	12,0	13,0	4,5	RPO	0750	0850	120	CN
75,0	90,0	11,5	12,5	5,0	RPO	0750	0900	115	CN
80,0	90,0	7,2	8,0	5,0	RPO	0800	0900	072	CN
80,0	90,0	8,0	9,0	5,0	RPO	0800	0900	080	CN
80,0	90,0	10,0	11,0	5,0	RPO	0800	0900	100	CN
80,0	90,0	12,0	13,0	5,0	RPO	0800	0900	120	CN
80,0	95,0	11,0	12,0	5,0	RPO	0800	0950	110	CN
80,0	95,0	11,0	12,0	5,0	RPO	0800	0950	110	CN
85,0	95,0	12,0	13,0	5,0	RPO	0850	0950	120	CN
85,0	100,0	9,0	10,0	5,5	RPO	0850	1000	090	CN
85,0	100,0	12,0	13,0	5,5	RPO	0850	1000	120	CN
90,0	100,0	8,0	9,0	5,0	RPO	0900	1000	080	CN



RPO

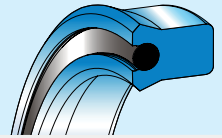

d_{h9}	D_{H10}	h	$E_{+0,2}$	C	ART / ITEM				
90,0	100,0	12,0	13,0	5,0	RPO	0900	1000	120	CN
90,0	105,0	11,5	12,5	5,0	RPO	0900	1050	115	CN
100,0	115,0	12,0	13,0	5,0	RPO	1000	1150	120	CN
105,0	120,0	15,0	16,0	5,5	RPO	1050	1200	150	CN
110,0	125,0	9,0	10,0	5,5	RPO	1100	1250	090	CN
110,0	125,0	12,0	13,0	5,5	RPO	1100	1250	120	CN
110,0	125,0	15,0	16,0	5,5	RPO	1100	1250	150	CN
115,0	126,0	15,0	16,0	5,5	RPO	1150	1260	150	CN

Nota: altre dimensioni non a catalogo a richiesta. Consultare il nostro ufficio tecnico.

Remark: please contact our technical dept. for further dimensions not included in the catalogue.

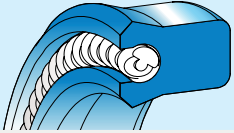

Alexander Spring®

MOLLA TIPO AS

Descrizione

Artic Alexander Spring® è il nuovo concetto innovativo di molla energizzante per tenute stelo idrauliche, in applicazioni molto gravose e in condizioni climatiche estreme:

Alexander Spring® sostituisce due concetti energizzanti principali attualmente sul mercato:

- O-ring o Q-ring, in diversi materiali elastomerici (soluzione più comune)
- Molle di metallo (che sono normalmente costose e difficili da produrre)

Grazie alla combinazione del giusto poliuretano e della Alexander Spring®, Artic Seals può garantire una tenuta ad alte prestazioni su un'ampia gamma di temperature.

Dati tecnici

Pressione: < 400 bar

Velocità: < 0.5 m/s

Temperatura:

- da - 50° C a + 90° C in combinazione con poliuretano BT (v. tabella 4 a p. 19)
- da - 30° C a + 135° C in combinazione con poliuretano GT (v. tabella 4 a p. 19)

Fluidi: fluidi e oli minerali
(v. tabella 3 a p. 14)

Materiale

Il materiale proposto è Tecnopolimero ad alta tecnologia e prestazioni, il quale garantisce resistenza ed elasticità in un intervallo veramente ampio di temperatura, da -50° a + 150°C.

Montaggio

Il montaggio avviene in cava anulare. Eliminare le bave e gli spigoli taglienti nella sede e sullo stelo per evitare che si danneggino le guarnizioni durante il montaggio. È consigliabile lubrificare la tenuta durante il montaggio per agevolare l'inserimento dello stelo. Per ulteriori informazioni leggere le istruzioni a p. 63.

AS TYPE SPRING

Description

Artic Alexander Spring® is the new innovative concept in energizing spring for hydraulic rod seals, in very heavy duty applications and extreme climatic conditions:

Alexander Spring® replace two energizing concepts normally the market has:

- O-Rings or Q-Rings, in different elastomeric material (most common solution)
- Metal springs (which are normally expensive and slow to produce)

Thanks to the combination of the correct polyurethane and the Alexander Spring®, Artic Seals can ensure a high performance seal over a wide range of temperature.

Technical data

Pressure: < 400 bar

Speed: < 0.5 m/s

Temperature:

- from - 50° C to + 90° C combined with polyurethane BT (see table 4, page 19)
- from - 30° C to + 135° C combined with polyurethane GT (see table 4, page 19)

Fluids: mineral fluids and oils
(see table 3, page 14)

Material

The proposed material is a very high performance and technologic Tecnopolimer, which ensures high elasticity and resistance in a very wide range of temperature from -50° up to 150°C.

Assembling

To prevent any damage to the seal, remove any flash and cutting edges in the housing and on the rod. The seal should always be lubricated before assembling in order to have easier insertion of the rod.

For further information please refer to the installation instructions on page 63.



Alexander Spring®

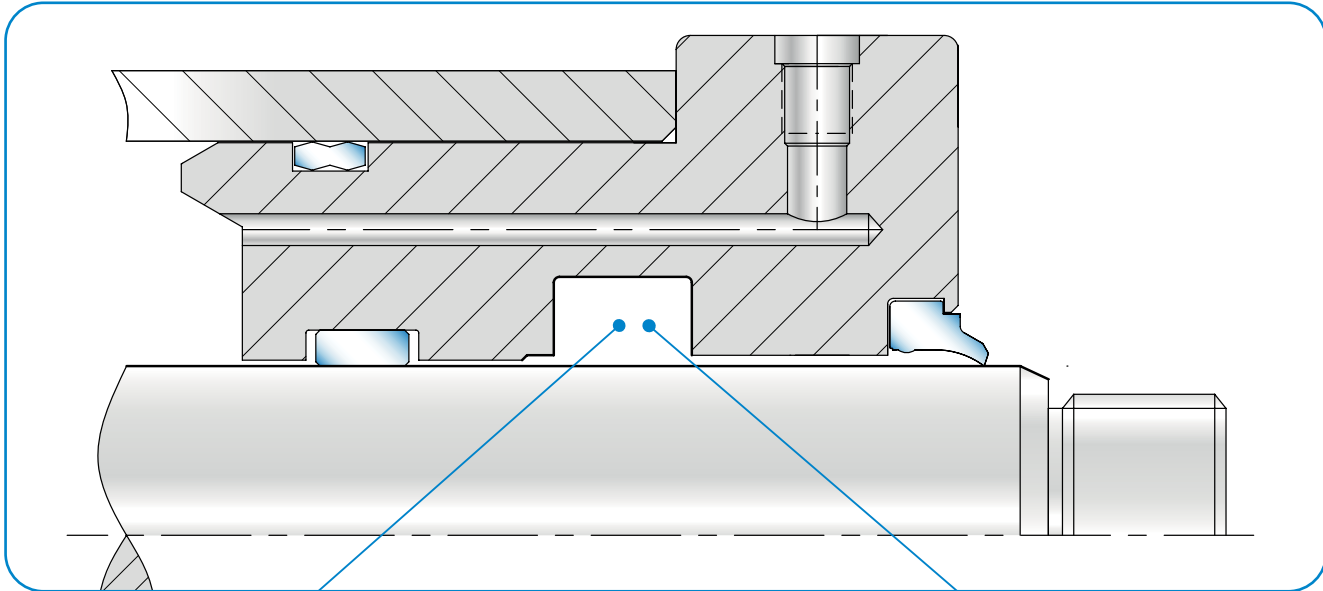
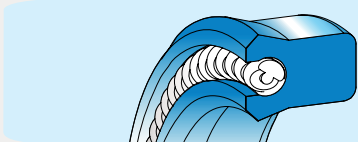

Oleodinamica
Hydraulic

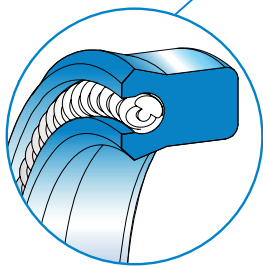

PATENT

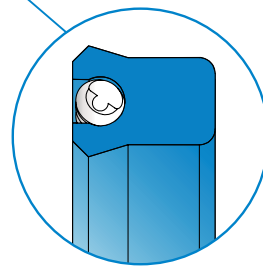
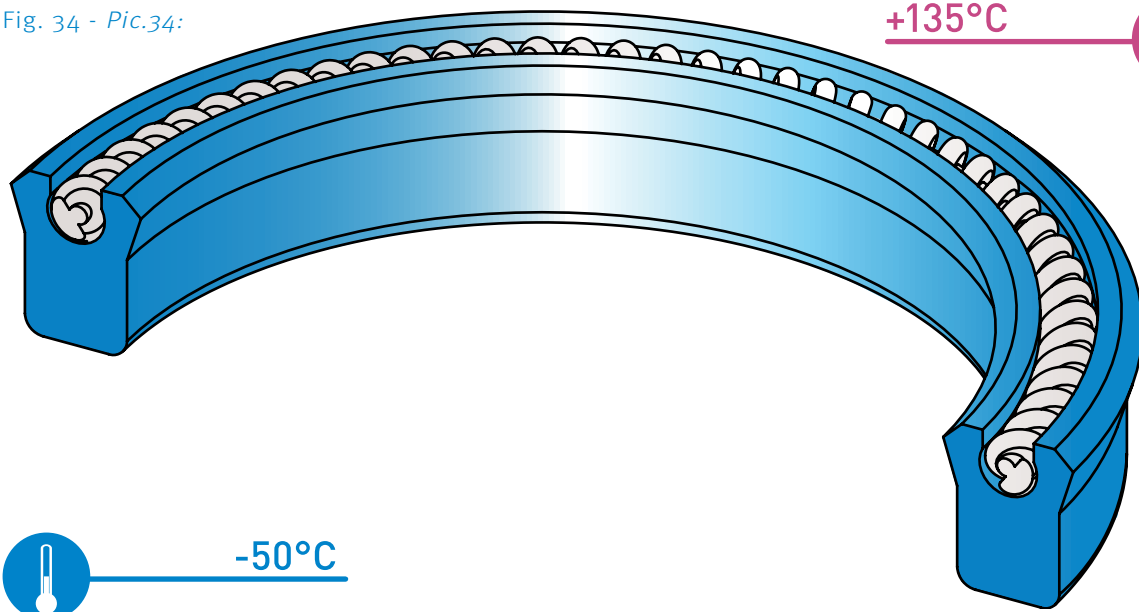

Fig. 34 - Pic.34:



+135°C



-50°C



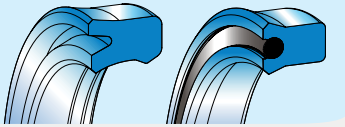

RSBI / RPOI

TENUTE STELO TIPO RSBI / RPOI

Descrizione

La gamma standard di Artic Seals riguardo le tenute stelo per idraulica in POLLICI presente le due famiglie tipo RSBI e RPOI

RSBI: progettata con labbro dinamico più corto rispetto a quello statico, ha impieghi dove risultano elevati i disallineamenti dello stelo e dove le pressioni possono raggiungere valori elevati, presenta sul lato dinamico un doppio labbro che ha più di una funzione:

- attenua eventuali fenomeni di stick-slip grazie al fluido trattenuto nell'intercapedine fra i due labbri;
- evita alle impurità di entrare dall'esterno;
- contrasta il ritiro del materiale alle basse temperature;
- funge da stabilizzatore.

RPOI: è caratterizzata dalla presenza di un O-Ring alloggiato nella gola interna tra il labbro dinamico e quello statico, il quale ha la funzione di energizzare i labbri per garantire la tenuta anche a basse pressioni. Questo profilo garantisce una tenuta perfetta anche in presenza di carichi laterali. L'O-Ring può essere fornito in diverse mescole, in base alle temperature di utilizzo.

Dati tecnici

Pressione: < 400 bar a temperatura di 60° C
 Velocità: < 0,5 m/s
 Temperatura: da - 35° C a + 100° C con punte fino a 110° C
 Fluidi: fluidi a base minerale

Materiale

Il materiale proposto è Co: TPU durezza 94Shore A.
 RPOI: L'o-ring in NBR 70 Shore A. (No).
 Codice materiale: CN.

Montaggio

Il montaggio avviene in cava anulare.
 Per evitare che si danneggino le guarnizioni durante il montaggio occorre eliminare le bave e gli spigoli taglienti nella sede e sullo stelo.
 E' consigliabile lubrificare la tenuta durante il montaggio per agevolare l'inserimento dello stelo.

RSBI / RPOI TYPE ROD SEAL

Description

Artic Seals standard range of hydraulic rod seals in INCH SIZES is represented by two sealing groups; RSBI and RPOI seal types.

RSBI: has a dynamic lip shorter than the static one and it is used in cases of high rod misalignments and possible high pressure, on the dynamic side, it presents a multifunctional double lip which:

- reduces stick slip effects because it retains oil between the secondary lip and primary lip;
- stops any external impurities;
- faces the material shrinkage at low temperatures;
- acts as a stabilizer.

RPOI is characterized by the installation of an O-Ring within the internal groove between both the static and dynamic sealing lips to ensure the seal is permanently energized even at low system pressure. This profile ensures a perfect seal even in the presence of lateral loads. The O-ring can be provided in different compounds, depending on the temperature of use.

Technical data

Pressure: < 400 bar at a temperature of 60° C
 Speed: < 0,5 m/s
 Temperature: from - 35° C to + 100° C, with peaks at 110° C
 Fluids: mineral-based fluids

Material

Material proposed is Co: TPU 94 Shore A hardness.
 RPOI: O-ring in NBR 70 Shore A (No).
 Compound reference: CN.

Assembling

To prevent any damage to the seal during assembly, remove all swarf and sharp edges within the housing and corresponding rod. The seal should always be lubricated before assembling in order to have easier insertion of the rod.



RSBI / RPOI

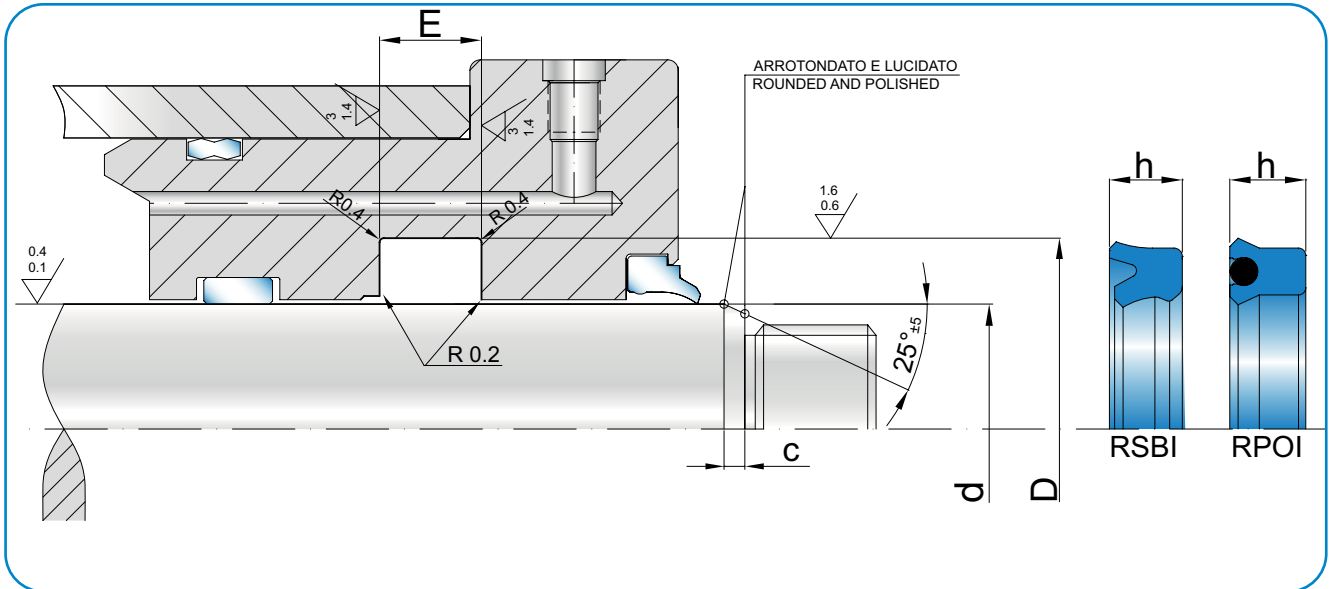
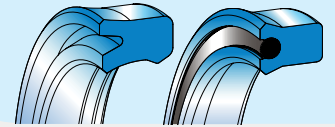

DH8		dh9		h		E+0,2		ART / ITEM					
inch	mm	inch	mm	inch	mm	inch	mm						
0,500	12,70	0,750	19,05	0,187	4,75	0,206	5,23	RSBI	RPOI	0500	0750	0187	Co/CN
0,500	12,70	0,750	19,05	0,250	6,35	0,275	6,98	RSBI	RPOI	0500	0750	0250	Co/CN
0,500	12,70	1,000	25,40	0,375	9,52	0,413	10,49	RSBI	RPOI	0500	1000	0375	Co/CN
0,750	19,05	1,000	25,40	0,250	6,35	0,275	6,98	RSBI	RPOI	0750	1000	0250	Co/CN
0,750	19,05	1,125	28,57	0,250	6,35	0,275	6,98	RSBI	RPOI	0750	1125	0250	Co/CN
1,000	25,40	1,250	31,75	0,187	4,75	0,206	5,23	RSBI	RPOI	1000	1250	0187	Co/CN
1,000	25,40	1,250	31,75	0,250	6,35	0,275	6,98	RSBI	RPOI	1000	1250	0250	Co/CN
1,000	25,40	1,375	34,92	0,250	6,35	0,275	6,98	RSBI	RPOI	1000	1375	0250	Co/CN
1,000	25,40	1,375	34,92	0,312	7,92	0,343	8,71	RSBI	RPOI	1000	1375	0312	Co/CN
1,000	25,40	1,500	38,10	0,250	6,35	0,275	6,98	RSBI	RPOI	1000	1500	0250	Co/CN
1,000	25,40	1,500	38,10	0,375	9,52	0,413	10,49	RSBI	RPOI	1000	1500	0375	Co/CN
1,125	28,57	1,375	34,92	0,187	4,75	0,206	5,23	RSBI	RPOI	1125	1375	0187	Co/CN
1,250	31,75	1,500	38,10	0,187	4,75	0,206	5,23	RSBI	RPOI	1250	1500	0187	Co/CN
1,250	31,75	1,500	38,10	0,250	6,35	0,275	6,98	RSBI	RPOI	1250	1500	0250	Co/CN
1,250	31,75	1,625	41,27	0,312	7,92	0,343	8,71	RSBI	RPOI	1250	1625	0312	Co/CN
1,250	31,75	1,750	44,45	0,375	9,52	0,413	10,49	RSBI	RPOI	1250	1750	0375	Co/CN
1,375	34,92	1,625	41,27	0,187	4,75	0,206	5,23	RSBI	RPOI	1375	1625	0187	Co/CN
1,375	34,92	1,750	44,45	0,312	7,92	0,343	8,71	RSBI	RPOI	1375	1750	0312	Co/CN
1,500	38,10	1,750	44,45	0,187	4,75	0,206	5,23	RSBI	RPOI	1500	1750	0187	Co/CN
1,500	38,10	1,750	44,45	0,250	6,35	0,275	6,98	RSBI	RPOI	1500	1750	0250	Co/CN
1,500	38,10	1,875	47,62	0,375	9,52	0,413	10,49	RSBI	RPOI	1500	1875	0375	Co/CN
1,500	38,10	2,000	50,80	0,312	7,92	0,343	8,71	RSBI	RPOI	1500	2000	0312	Co/CN
1,500	38,10	2,000	50,80	0,375	9,52	0,413	10,49	RSBI	RPOI	1500	2000	0375	Co/CN
1,750	44,45	2,125	53,97	0,250	6,35	0,275	6,98	RSBI	RPOI	1750	2125	0250	Co/CN
1,750	44,45	2,125	53,97	0,312	7,92	0,343	8,71	RSBI	RPOI	1750	2125	0312	Co/CN
1,750	44,45	2,125	53,97	0,375	9,52	0,413	10,49	RSBI	RPOI	1750	2125	0375	Co/CN
1,750	44,45	2,250	57,15	0,375	9,52	0,413	10,49	RSBI	RPOI	1750	2250	0375	Co/CN

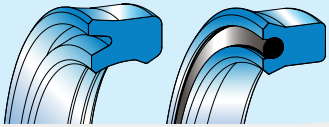

RSBI / RPOI

D _{H8}		d _{h9}		h		E _{+0,2}		ART / ITEM					
inch	mm	inch	mm	inch	mm	inch	mm						
2,000	50,80	2,250	57,15	0,187	4,75	0,206	5,23	RSBI	RPOI	2000	2250	0187	Co/CN
2,000	50,80	2,375	60,32	0,250	6,35	0,275	6,98	RSBI	RPOI	2000	2375	0250	Co/CN
2,000	50,80	2,375	60,32	0,312	7,92	0,343	8,71	RSBI	RPOI	2000	2375	0312	Co/CN
2,000	50,80	2,500	63,50	0,375	9,52	0,413	10,94	RSBI	RPOI	2000	2500	0375	Co/CN
2,250	57,15	2,625	66,67	0,312	7,92	0,343	8,71	RSBI	RPOI	2250	2625	0312	Co/CN
2,250	57,15	2,750	69,85	0,375	9,52	0,413	10,49	RSBI	RPOI	2250	2750	0375	Co/CN
2,500	63,50	2,875	73,02	0,375	9,52	0,413	10,49	RSBI	RPOI	2500	2875	0375	Co/CN
2,500	63,50	3,000	76,20	0,375	9,52	0,413	10,49	RSBI	RPOI	2500	3000	0375	Co/CN
2,500	63,50	3,125	79,37	0,500	12,70	0,550	13,97	RSBI	RPOI	2500	3125	0500	Co/CN
2,750	69,85	3,250	82,55	0,375	9,52	0,413	10,49	RSBI	RPOI	2750	3250	0375	Co/CN
2,750	69,85	3,375	85,72	0,500	12,70	0,550	13,97	RSBI	RPOI	2750	3375	0500	Co/CN
3,000	76,20	3,500	88,90	0,375	9,52	0,413	10,49	RSBI	RPOI	3000	3500	0375	Co/CN
3,000	76,20	3,750	95,25	0,500	12,70	0,550	13,97	RSBI	RPOI	3000	3750	0500	Co/CN
3,250	82,55	3,750	95,25	0,375	9,52	0,413	10,49	RSBI	RPOI	3250	3750	0375	Co/CN
3,500	88,90	4,000	101,60	0,312	7,92	0,343	8,71	RSBI	RPOI	3500	4000	0312	Co/CN
3,500	88,90	4,000	101,60	0,375	9,52	0,413	10,49	RSBI	RPOI	3500	4000	0375	Co/CN
3,500	88,90	4,125	104,77	0,500	12,70	0,550	13,97	RSBI	RPOI	3500	4125	0500	Co/CN
3,750	95,25	4,250	107,95	0,375	9,52	0,413	10,49	RSBI	RPOI	3750	4250	0375	Co/CN
3,750	95,25	4,375	111,12	0,500	12,70	0,550	13,97	RSBI	RPOI	3750	4375	0500	Co/CN
4,000	101,60	4,500	114,30	0,375	9,52	0,413	10,49	RSBI	RPOI	4000	4500	0375	Co/CN
4,000	101,60	4,500	114,30	0,562	14,27	0,618	15,69	RSBI	RPOI	4000	4500	0562	Co/CN
4,250	107,95	4,750	120,65	0,375	9,52	0,413	10,49	RSBI	RPOI	4250	4750	0375	Co/CN
4,250	107,95	4,750	120,65	0,562	14,27	0,618	15,69	RSBI	RPOI	4250	4750	0562	Co/CN
4,500	114,30	5,000	127,00	0,375	9,52	0,413	10,49	RSBI	RPOI	4500	5000	0375	Co/CN
4,500	114,30	5,250	133,35	0,625	15,87	0,688	17,47	RSBI	RPOI	4500	5250	0625	Co/CN
5,000	127,00	5,500	139,70	0,375	9,52	0,413	10,49	RSBI	RPOI	5000	5500	0375	Co/CN
5,000	127,00	5,750	146,05	0,625	15,87	0,688	17,47	RSBI	RPOI	5000	5750	0625	Co/CN

Nota: altre dimensioni non a catalogo a richiesta. Consultare il nostro ufficio tecnico.

Remark: please contact our technical dept. for further dimensions not included in the catalogue.



Index

Rod Seals

Piston Seals

Wipers

Wear Rings

Static Seals

Materials



ARTIC SEALS™

RSBI / RPOI

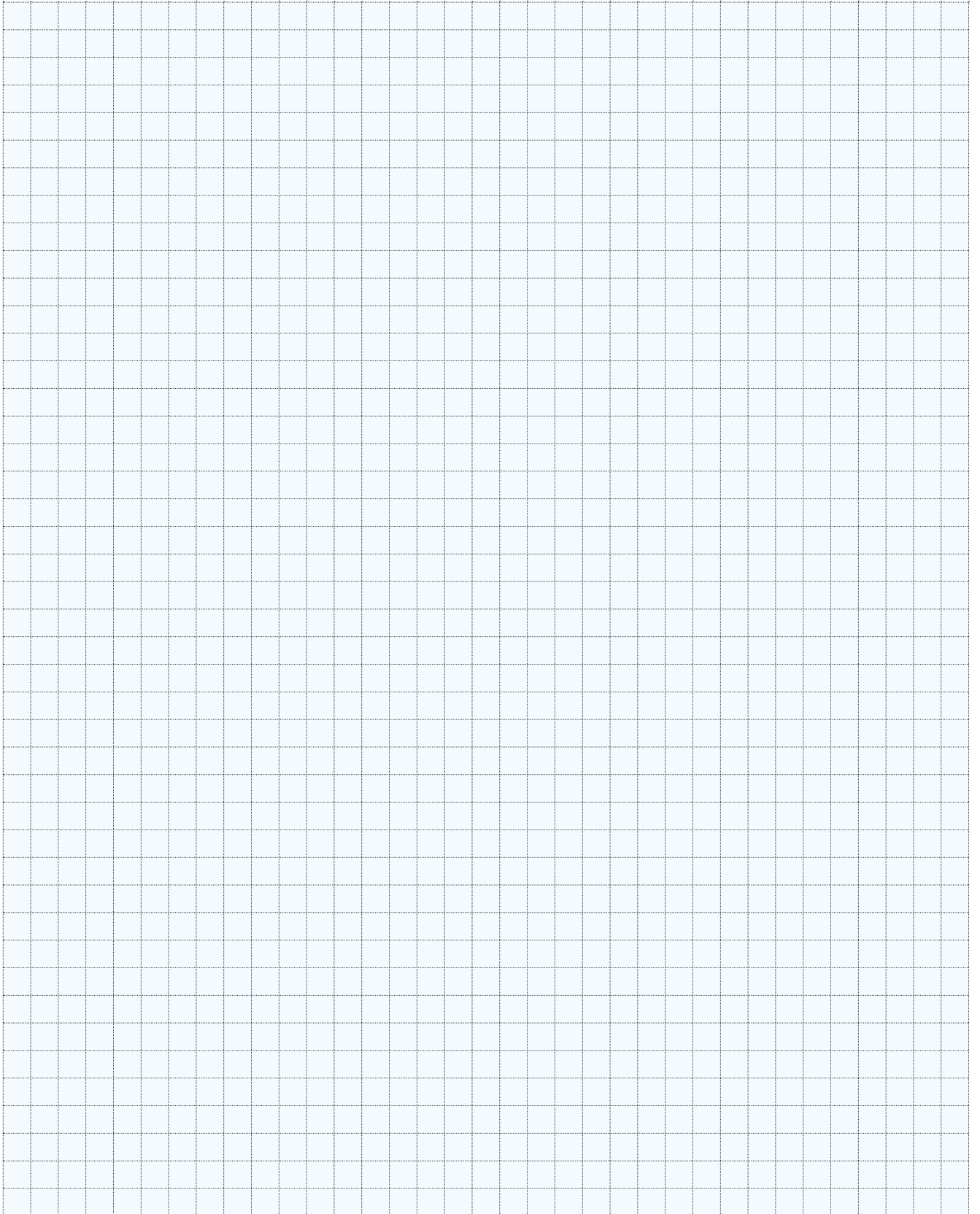
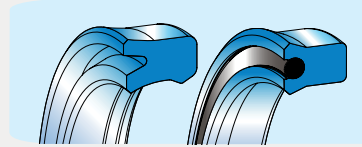

Oleodinamica
Hydraulic

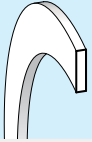

RAA

ANELLI ANTIETRUZIONE TIPO RAA

Descrizione

Gli anelli antiestrusione sono utilizzati a supporto della guarnizione, dove il gioco di accoppiamento tra la testata e lo stelo risulta ampio e le pressioni di esercizio molto elevate (superiore a 250 bar).

Dati Tecnici

Pressione: < 600 bar
 Velocità: < 1 m/s
 Temperatura: da - 30° C a + 100° C
 Fluidi: fluidi e oli minerali
 (v. tabella 3 a p. 14)

Materiale

Il materiale standard è resina acetlica POM
 Codice materiale: R2

Montaggio

Il montaggio può avvenire in sede anulare con anello tagliato o anello intero.

RAA TYPE ANTIEXTRUSION RING

Description

The anti-extrusion rings are used to support the gasket, where the coupling clearance between the cylinder head and the stem is wide and the operating pressures are very high (over 250 bar).

Technical data

Pressure: < 600 bar
 Speed: < 1 m/s
 Temperature: from - 30° C up to + 100° C
 Fluid: mineral fluids and oils
 (see table 3, page 14)

Material

Standard material is acetalic resin POM
 Compound reference: R2

Assembling

Assembling can be in the annular groove ring with cut or whole ring.



RAA

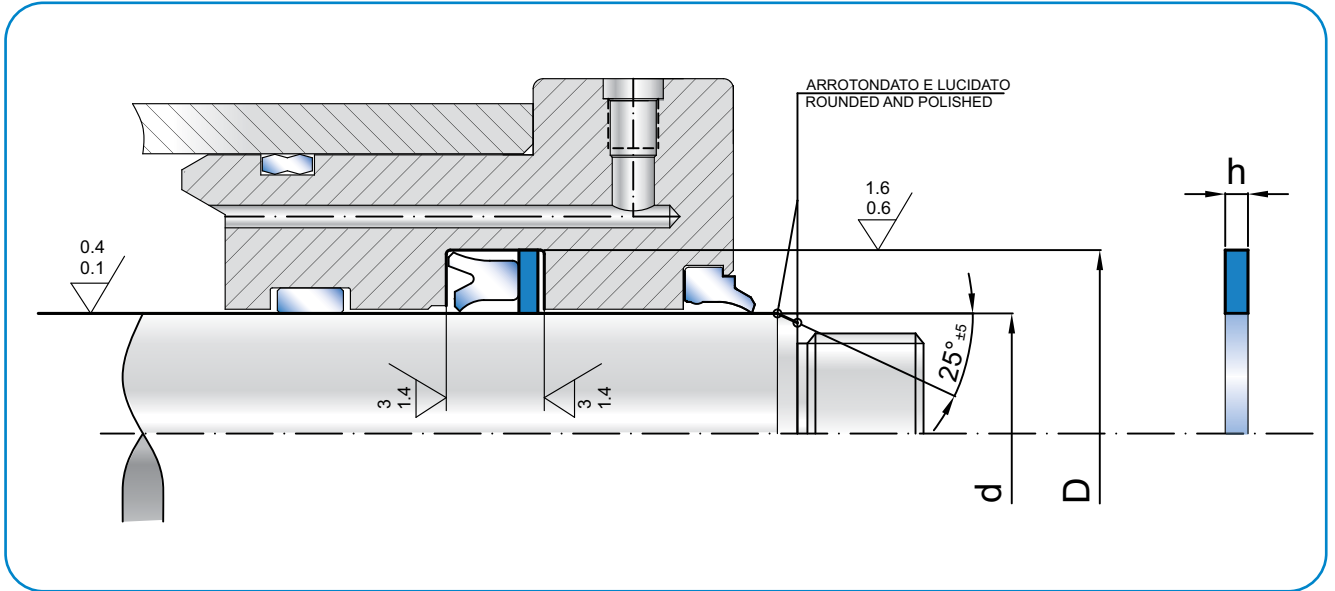
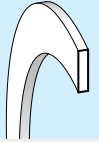

d _{H9}	D _{H10}	h	ART / ITEM
16,00	24,00	1,00	RAA 0160 0240 010 R2
28,00	36,00	1,50	RAA 0280 0360 015 R2
30,00	38,00	1,50	RAA 0300 0380 015 R2
30,0	40,0	2,00	RAA 0300 0400 020 R2
30,0	40,0	2,50	RAA 0300 0400 025 R2
30,80	37,00	1,40	RAA 0308 0370 014 R2
32,00	39,00	1,50	RAA 0320 0390 015 R2
32,00	40,00	1,50	RAA 0320 0400 015 R2
35,00	43,00	1,50	RAA 0350 0430 015 R2
35,00	44,00	1,50	RAA 0350 0440 015 R2
35,00	45,00	1,50	RAA 0350 0450 015 R2
36,00	47,30	1,50	RAA 0360 0473 015 R2
37,40	48,00	3,00	RAA 0374 0480 030 R2
38,00	46,00	1,50	RAA 0380 0460 015 R2
40,00	48,00	1,40	RAA 0400 0480 014 R2
40,00	50,00	2,00	RAA 0400 0500 020 R2
40,00	50,00	1,50	RAA 0400 0500 015 R2
42,00	52,00	1,50	RAA 0420 0520 015 R2
42,00	52,00	1,50	RAA 0420 0520 015 R2
45,00	53,00	1,50	RAA 0450 0530 015 R2
45,00	55,00	1,50	RAA 0450 0550 015 R2
45,00	55,00	2,00	RAA 0450 0550 020 R2
45,20	51,40	1,40	RAA 0452 0514 014 R2
50,00	58,00	1,50	RAA 0500 0580 015 R2

d _{H9}	D _{H10}	h	ART / ITEM
50,00	59,00	1,50	RAA 0500 0590 015 R2
50,00	60,00	1,20	RAA 0500 0600 012 R2
50,00	60,00	1,50	RAA 0500 0600 015 R2
53,00	63,00	2,00	RAA 0530 0630 020 R2
56,00	66,00	1,50	RAA 0560 0660 015 R2
60,00	70,00	1,50	RAA 0600 0700 015 R2
60,00	75,00	1,50	RAA 0600 0750 015 R2
63,00	67,80	3,00	RAA 0630 0678 030 R2
63,00	82,00	1,50	RAA 0630 0820 015 R2
65,00	75,00	1,50	RAA 0650 0750 015 R2
65,00	77,00	1,50	RAA 0650 0770 015 R2
70,00	80,00	1,50	RAA 0700 0800 015 R2
70,00	80,00	2,00	RAA 0700 0800 020 R2
75,00	85,00	1,50	RAA 0750 0850 015 R2
75,00	90,00	1,50	RAA 0750 0900 015 R2
80,00	90,00	1,50	RAA 0800 0900 015 R2
83,00	93,00	1,50	RAA 0830 0930 015 R2
90,00	100,0	3,00	RAA 0900 1000 030 R2
90,00	105,00	1,50	RAA 0900 1050 015 R2
100,00	110,00	3,00	RAA 1000 1100 030 R2
100,00	115,00	1,50	RAA 1000 1150 015 R2

Nota: altre dimensioni non a catalogo a richiesta. Consultare il nostro ufficio tecnico.

Remark: please contact our technical dept. for further dimensions not included in the catalogue.

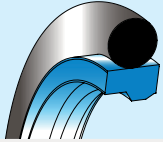

TSS / P

TENUTA STELO TIPO TSS/P

Descrizione

La TSS/P è una guarnizione in materiale poliuretano di durezza di 60 Sh D per stelo a semplice effetto, energizzata con o-ring in NBR. Le dimensioni delle sedi sono intercambiabili con le TSS. È utilizzata sia come guarnizione primaria sia come secondaria (tandem).

È consigliato montare la TSS/P con un raschiatore bidirezionale poiché il profilo permette il rientro nel cilindro dell'olio (blow-by).

L'utilizzo è su cilindri con pressioni elevate e frequenti colpi d'ariete.

Dati Tecnici

Pressione: < 600 bar

Velocità: < 5 m/s

Temperatura: da - 30°C a + 110°C, con punte per periodi brevi fino a 120°C.

Fluidi: fluidi e oli minerali
(v. tabella 3 a p. 14)

Materiale

Il materiale utilizzato è un poliuretano poliesteri di durezza 60 Sh D.

Codice materiale: EN

Montaggio

Il montaggio avviene in cava anulare chiusa. L'elasticità del materiale favorisce l'inserimento in sede. Togliere le bave di lavorazione meccanica per non rovinare la guarnizione.

Per ulteriori informazioni leggere le istruzioni a p. 63

TSS / P TYPE ROD SEAL

Description

The TSS / P is a Polyurethane 60 Shore D seal for a simple acting rod energized with an NBR O-Ring.

The dimensions of the groove are interchangeable with the TSS. This type of seal is used both as a primary that as a secondary seal (tandem).

Recommended use the TSS / P with a bidirectional wiper because the profile allows the return oil into the cylinder (blow-by).

The common use is on a cylinders that have high pressure and frequent water hammer.

Technical data

Pressure: < 600 bar

Speed: < 5 m/s

Temperature: from - 30°C up to + 110°C
with short peaks till 120°C

Fluid: mineral fluids and oils
(see table 3, page 14)

Material

The material is a polyurethane 60 Sh D hardness
Compound reference: EN

Assembling

Installation is in the annular recess closed.

The elasticity of the material favors the inclusion in the seat. Remove burrs from machining, to avoid damaging the seal.

For further information please refer to the installation instructions on page 63.



TSS/P

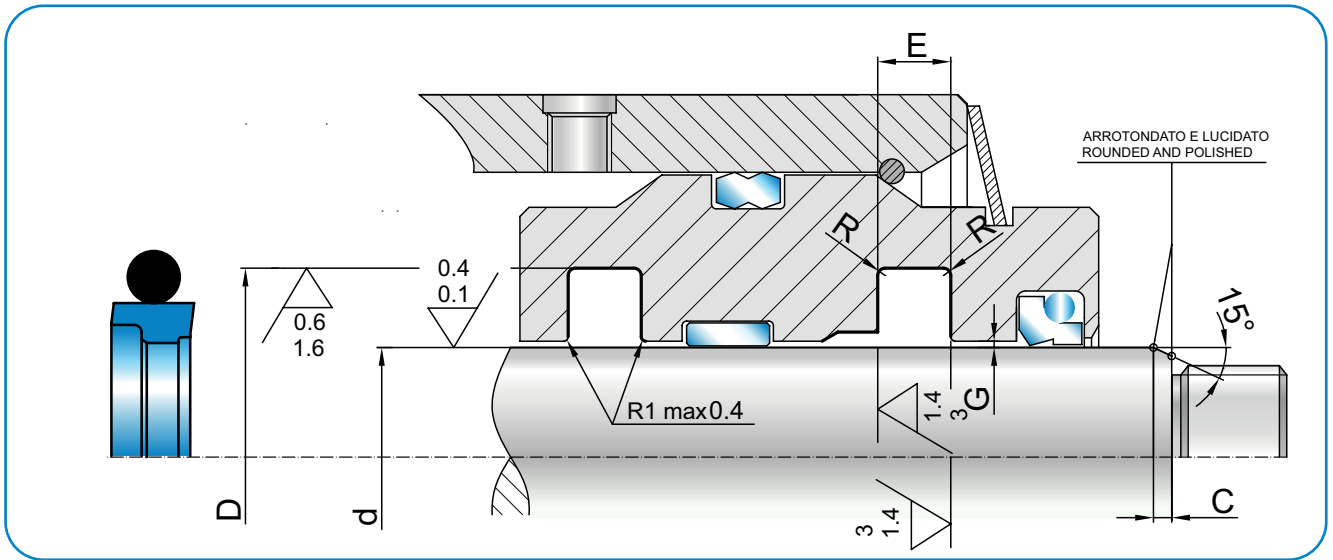
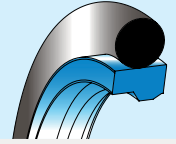

d_{H9}	D_{H9}	$E_{+0,2}$	O-R	C	ART / ITEM				
4,0	8,9	2,20	010	5,0	TSS	0040	0089	022	EN
5,0	9,9	2,20	010	5,0	TSS	0050	099	022	EN
7,0	11,9	2,20	012	5,0	TSS	0070	0119	022	EN
8,0	15,3	3,20	111	5,0	TSS	0080	0153	032	EN
10,0	17,3	3,20	112	5,0	TSS	0100	0173	032	EN
12,0	19,3	3,20	114	5,0	TSS	0120	0193	032	EN
14,0	21,3	3,20	115	5,0	TSS	0140	0213	032	EN
15,0	22,3	3,20	116	5,0	TSS	0150	0223	032	EN
16,0	23,3	3,20	116	5,0	TSS	0160	0233	032	EN
18,0	25,3	3,20	117	5,0	TSS	0180	0253	032	EN
20,0	30,7	4,20	214	5,0	TSS	0200	0307	042	EN
22,0	32,7	4,20	215	5,0	TSS	0220	0327	042	EN
24,0	34,7	4,20	216	5,0	TSS	0240	0347	042	EN
25,0	32,3	3,20	122	5,0	TSS	0250	0323	032	EN
25,0	35,7	4,20	217	5,0	TSS	0250	0357	042	EN
26,0	36,7	4,20	218	5,0	TSS	0260	0367	042	EN
28,0	38,7	4,20	219	5,0	TSS	0280	0387	042	EN
30,0	40,7	4,20	220	5,0	TSS	0300	0407	042	EN
32,0	42,7	4,20	221	5,0	TSS	0320	0427	042	EN
35,0	45,7	4,20	222	5,0	TSS	0350	0457	042	EN
37,0	47,7	4,20	223	5,0	TSS	0370	0477	042	EN
38,0	53,1	6,30	327	5,0	TSS	0380	0531	063	EN
40,0	47,3	3,20	130	5,0	TSS	0400	0473	032	EN
40,0	55,1	6,30	328	5,0	TSS	0400	0551	063	EN
42,0	52,7	4,20	225	5,0	TSS	0420	0527	042	EN
42,0	57,1	6,30	328	5,0	TSS	0420	0571	063	EN
45,0	55,7	4,20	226	5,0	TSS	0450	0557	042	EN
45,0	60,1	6,30	329	5,0	TSS	0450	0601	063	EN
48,0	63,1	6,30	330	5,0	TSS	0480	0631	063	EN
50,0	65,1	6,30	331	5,0	TSS	0500	0651	063	EN

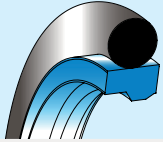

TSS/P

d _{H9}	D _{H9}	E _{+0,2}	O-R	C	ART / ITEM				
52,0	67,1	6,30	331	5,0	TSS	0520	0671	063	EN
55,0	70,1	6,30	332	5,0	TSS	0550	0701	063	EN
58,0	73,1	6,30	333	5,0	TSS	0580	0731	063	EN
60,0	75,1	6,30	334	5,0	TSS	0600	0751	063	EN
65,0	80,1	6,30	335	5,0	TSS	0650	0801	063	EN
70,0	85,1	6,30	337	5,0	TSS	0700	0851	063	EN
75,0	90,1	6,30	339	5,0	TSS	0750	0901	063	EN
80,0	95,1	6,30	340	5,0	TSS	0800	0951	063	EN
85,0	100,1	6,30	342	5,0	TSS	0850	1001	063	EN
90,0	105,1	6,30	343	5,0	TSS	0900	1051	063	EN
95,0	110,1	6,30	345	7,0	TSS	0950	1101	063	EN
100,0	115,1	6,30	346	7,0	TSS	1000	1151	063	EN
110,0	125,1	6,30	350	7,0	TSS	1100	1251	063	EN
120,0	135,1	6,30	353	7,0	TSS	1200	1351	063	EN
125,0	140,1	6,30	354	7,0	TSS	1250	1401	063	EN
130,0	145,1	6,30	356	7,0	TSS	1300	1451	063	EN
140,0	155,1	6,30	359	7,0	TSS	1400	1551	063	EN
150,0	165,1	6,30	361	7,0	TSS	1500	1651	063	EN
155,0	170,1	6,30	362	7,0	TSS	1550	1701	063	EN
160,0	175,1	6,30	363	7,0	TSS	1600	1751	063	EN
170,0	185,1	6,30	365	7,0	TSS	1700	1851	063	EN
175,0	190,1	6,30	366	7,0	TSS	1750	1901	063	EN
180,0	195,1	6,30	366	7,0	TSS	1800	1951	063	EN
185,0	200,1	6,30	367	7,0	TSS	1850	2001	063	EN
190,0	205,1	6,30	368	7,0	TSS	1900	2051	063	EN
195,0	210,1	6,30	368	7,0	TSS	1950	2101	063	EN
200,0	220,5	8,10	445	10,0	TSS	2000	2205	081	EN
210,0	230,5	8,10	446	10,0	TSS	2100	2305	081	EN
220,0	240,5	8,10	447	10,0	TSS	2200	2405	081	EN
225,0	245,5	8,10	447	10,0	TSS	2250	2455	081	EN
230,0	250,5	8,10	448	10,0	TSS	2300	2505	081	EN
240,0	260,5	8,10	448	10,0	TSS	2400	2605	081	EN
250,0	270,5	8,10	449	10,0	TSS	2500	2705	081	EN

Nota: altre dimensioni non a catalogo a richiesta. Consultare il nostro ufficio tecnico.

Remark: please contact our technical dept. for further dimensions not included in the catalogue.



Index

Rod Seals

Piston Seals

Wipers

Wear Rings

Static Seals

Materials



ARTIC SEALS™

TSS/P

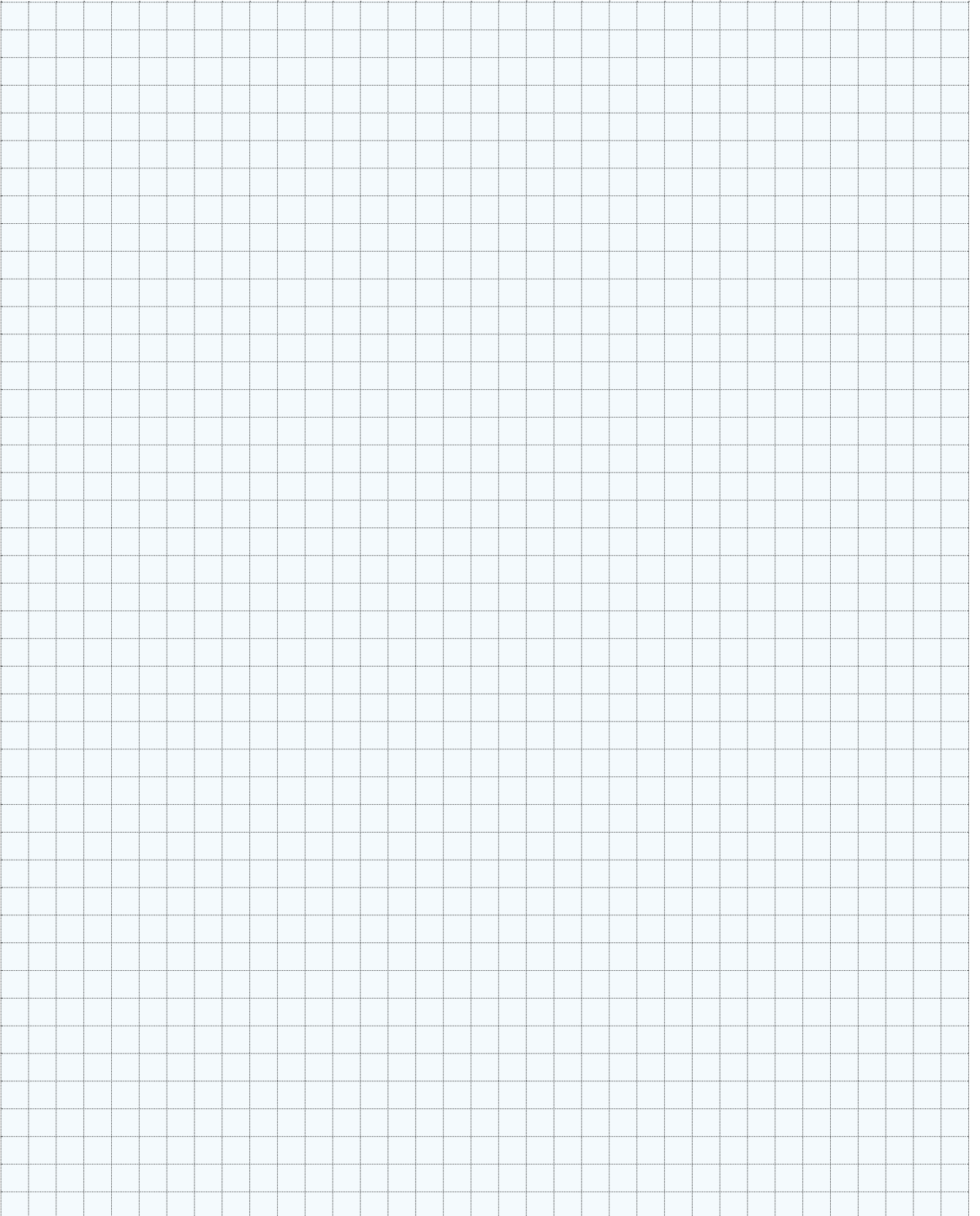
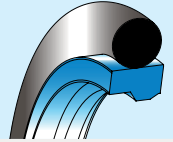

Oleodinamica
Hydraulic

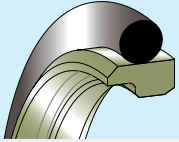

TSS

TENUTA STELO TIPO TSS

Descrizione

La tenuta stelo tipo TSS consta di un anello in PTFE opportunamente sagomato e caricato bronzo, avente funzione di tenuta dinamica, e di un anello o-ring che effettua la tenuta statica e contemporaneamente svolge un effetto energizzante.

Dati Tecnici

Pressione: < 600 bar

Velocità: < 15 m/s

Temperatura: per il tipo standard con OR in nitrile da - 30°C a + 100°C, con punte per periodi brevi fino a 120°C.

Per range di temperature differente occorre sostituire l'o-ring con un altro tipo più idoneo.

Materiale

Per il tipo standard PTFE isostatico caricato bronzo e o-ring in nitrile.

Codice materiale: TN

Per applicazioni fino a <250 bar è possibile utilizzare materiale alternativo PTFE estruso caricato bronzo

Codice materiale : TM2

Montaggio

- Le guarnizioni in PTFE necessitano di precauzioni estremamente rigorose, maggiori che per tutte le altre tipologie di tenuta. È fondamentale eliminare gli spigoli vivi e le bave nelle sedi. Il montaggio delle guarnizioni per lo stelo segue normalmente questa sequenza:
- installare l'o-ring nella sede
- deformare l'anello in PTFE con l'ausilio di un mandrino e una bussola a espansione
- calibrare con una bussola opportunamente dimensionata (p. 64).

TSS TYPE ROD SEAL

Description

The TSS rod seal is composed of two rings. The dynamic seal is a ring in bronze filled PTFE while the static seal is an O-Ring also acting as energizer.

Technical data

Pressure: < 600 bar

Speed: < 15 m/s

Temperature: from - 30°C up to + 100°C for the standard type with nitrile OR. Short peaks till 120°C. For a different temperature range, the O-Ring should be replaced by a more suitable model.

Material

Bronze-filled isostatic PTFE for the standard type, and is NBR (Nitrile butadiene rubber) O-Ring.

Compound reference: TN

For applications until <250 bar is possible to use alternative material Bronze-filled extruded PTFE

Compound reference: TM2

Assembling

PTFE seals require careful assembling operations in comparison to other types of seals. It is necessary to remove flashes and/or cutting edges in the grooves. The rod seal is usually assembled in the following sequence:

- fit the O-Ring into the groove
- twist the PTFE ring using a mandrel and a expansion bush
- calibrate with a plastic conical tool (Page 64).



TSS

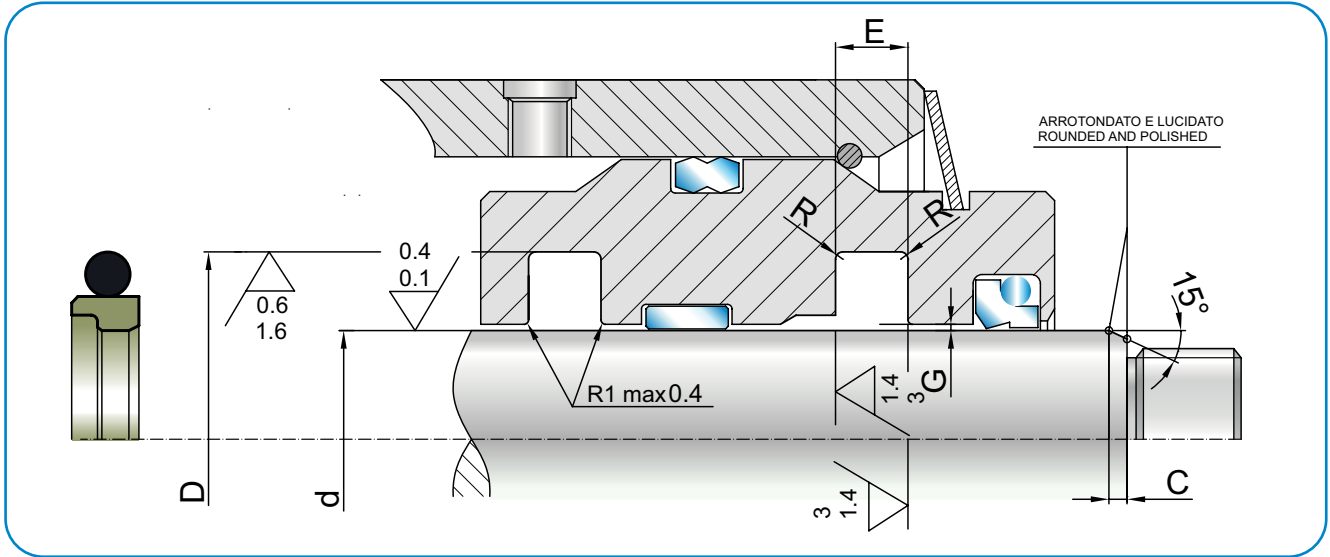
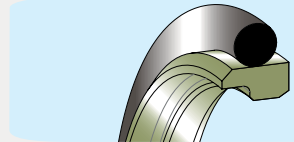

d _{h9}	D _{H9}	E _{+0,2}	O-R	C	ART / ITEM
4,0	8,9	2,20	010	5,0	TSS 0040 0089 022 TN
5,0	9,9	2,20	010	5,0	TSS 0050 099 022 TN
7,0	11,9	2,20	012	5,0	TSS 0070 0119 022 TN
8,0	15,3	3,20	111	5,0	TSS 0080 0153 032 TN
10,0	17,3	3,20	112	5,0	TSS 0100 0173 032 TN
12,0	19,3	3,20	114	5,0	TSS 0120 0193 032 TN
14,0	21,3	3,20	115	5,0	TSS 0140 0213 032 TN
15,0	22,3	3,20	116	5,0	TSS 0150 0223 032 TN
16,0	23,3	3,20	116	5,0	TSS 0160 0233 032 TN
18,0	25,3	3,20	117	5,0	TSS 0180 0253 032 TN
20,0	30,7	4,20	214	5,0	TSS 0200 0307 042 TN
22,0	32,7	4,20	215	5,0	TSS 0220 0327 042 TN
24,0	34,7	4,20	216	5,0	TSS 0240 0347 042 TN
25,0	35,7	4,20	217	5,0	TSS 0250 0357 042 TN
26,0	36,7	4,20	218	5,0	TSS 0260 0367 042 TN
28,0	38,7	4,20	219	5,0	TSS 0280 0387 042 TN
30,0	40,7	4,20	220	5,0	TSS 0300 0407 042 TN
32,0	42,7	4,20	221	5,0	TSS 0320 0427 042 TN
35,0	45,7	4,20	222	5,0	TSS 0350 0457 042 TN
37,0	47,7	4,20	223	5,0	TSS 0370 0477 042 TN
38,0	53,1	6,30	327	5,0	TSS 0380 0531 063 TN
40,0	55,1	6,30	328	5,0	TSS 0400 0551 063 TN
42,0	57,1	6,30	328	5,0	TSS 0420 0571 063 TN
45,0	60,1	6,30	329	5,0	TSS 0450 0601 063 TN
48,0	63,1	6,30	330	5,0	TSS 0480 0631 063 TN
50,0	65,1	6,30	331	5,0	TSS 0500 0651 063 TN
52,0	67,1	6,30	331	5,0	TSS 0520 0671 063 TN
55,0	70,1	6,30	332	5,0	TSS 0550 0701 063 TN
58,0	73,1	6,30	333	5,0	TSS 0580 0731 063 TN
60,0	75,1	6,30	334	5,0	TSS 0600 0751 063 TN

d _{h9}	D _{H9}	E _{+0,2}	O-R	C	ART / ITEM
65,0	80,1	6,30	335	5,0	TSS 0650 0801 063 TN
70,0	85,1	6,30	337	5,0	TSS 0700 0851 063 TN
75,0	90,1	6,30	339	5,0	TSS 0750 0901 063 TN
80,0	95,1	6,30	340	5,0	TSS 0800 0951 063 TN
85,0	100,1	6,30	342	5,0	TSS 0850 1001 063 TN
90,0	105,1	6,30	343	5,0	TSS 0900 1051 063 TN
95,0	110,1	6,30	345	7,0	TSS 0950 1101 063 TN
100,0	115,1	6,30	346	7,0	TSS 1000 1151 063 TN
110,0	125,1	6,30	350	7,0	TSS 1100 1251 063 TN
120,0	135,1	6,30	353	7,0	TSS 1200 1351 063 TN
125,0	140,1	6,30	354	7,0	TSS 1250 1401 063 TN
130,0	145,1	6,30	356	7,0	TSS 1300 1451 063 TN
140,0	155,1	6,30	359	7,0	TSS 1400 1551 063 TN
150,0	165,1	6,30	361	7,0	TSS 1500 1651 063 TN
155,0	170,1	6,30	362	7,0	TSS 1550 1701 063 TN
160,0	175,1	6,30	363	7,0	TSS 1600 1751 063 TN
170,0	185,1	6,30	365	7,0	TSS 1700 1851 063 TN
175,0	190,1	6,30	366	7,0	TSS 1750 1901 063 TN
180,0	195,1	6,30	366	7,0	TSS 1800 1951 063 TN
185,0	200,1	6,30	367	7,0	TSS 1850 2001 063 TN
190,0	205,1	6,30	368	7,0	TSS 1900 2051 063 TN
195,0	210,1	6,30	368	7,0	TSS 1950 2101 063 TN
200,0	220,5	8,10	445	10,0	TSS 2000 2205 081 TN
210,0	230,5	8,10	446	10,0	TSS 2100 2305 081 TN
220,0	240,5	8,10	447	10,0	TSS 2200 2405 081 TN
225,0	245,5	8,10	447	10,0	TSS 2250 2455 081 TN
230,0	250,5	8,10	448	10,0	TSS 2300 2505 081 TN
240,0	260,5	8,10	448	10,0	TSS 2400 2605 081 TN
250,0	270,5	8,10	449	10,0	TSS 2500 2705 081 TN

Oleodinamica
Hydraulic

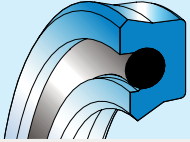

RSO

TENUTA STELO TIPO RSO

Descrizione

La tenuta tipo RSO è stata sviluppata per sostituire e/o lavorare in tandem con guarnizioni a gradino in PTFE, viste le identiche dimensioni di sede, ed è dotata di una gola arrotondata interna dove si può alloggiare un o-ring per energizzare il labbro di tenuta dinamico e quello statico anche in assenza di pressione.

Questo profilo può essere utilizzato anche a bassissime velocità e pressioni con risultati eccellenti per il basso attrito sviluppato. Presenta ridotti ingombri assiali e quindi lavorazioni di sede estremamente semplici.

Dati tecnici

Pressione: < 250 bar a temperatura di 60° C
 Velocità: < 0.5 m/s
 Temperatura: da - 35° C a + 100° C con punte fino a 110° C
 Fluidi: oli a base minerale
 (v. tabella 3 a p. 14)

Materiale

Il materiale proposto per la tenuta è il poliuretano tipo Co ad alto modulo elastico (standard 93 Sh A), basso compression-set ed elevata resistenza all'abrasione energizzato da un o-ring in NBR 70 (No).

Codice materiale: CN

Montaggio

Eliminare le bave e gli spigoli taglienti come per tutte le sedi dove alloggia la guarnizione.
 Per ulteriori informazioni leggere le istruzioni a p. 63.

RSO TYPE ROD SEAL

Description

The RSO seal type has been developed to replace or work jointly with stepseals in PTFE, because of the same groove dimension.

Internally it has a round groove where an O-ring can be housed. The O-Ring acts as energizer for the static and dynamic sealing lips even without pressure.

This profile has also excellent results at very low speed and pressure, because of the low friction. The machining of the groove is easier thanks to the reduced axial dimension.

Technical data

Pressure: < 250 bar at a temperature of 60° C
 Speed: < 0.5 m/s
 Temperature: from - 35° C to + 100° C, with peaks till 110° C
 Fluids: mineral oils (see TABLE I, pages 12-13)
 (see table 3, page 14)

Material

The proposed material is a "Co" type polyurethane, with high elasticity modulus, low compression-set and high abrasion resistance.

The hardness is 93 Shore A \pm 2, energized with O-ring in NBR 70 (No).

Compound reference: CN

Assembling

As for all seal housings, remove any flash or cutting edges.

For further information please refer to the installation instructions on page 63.

* in conformità alle norme ISO/DIN 5597 e ISO 5597/1 – in accordance with ISO/DIN 5597 and ISO 5597/1 norms



RSO

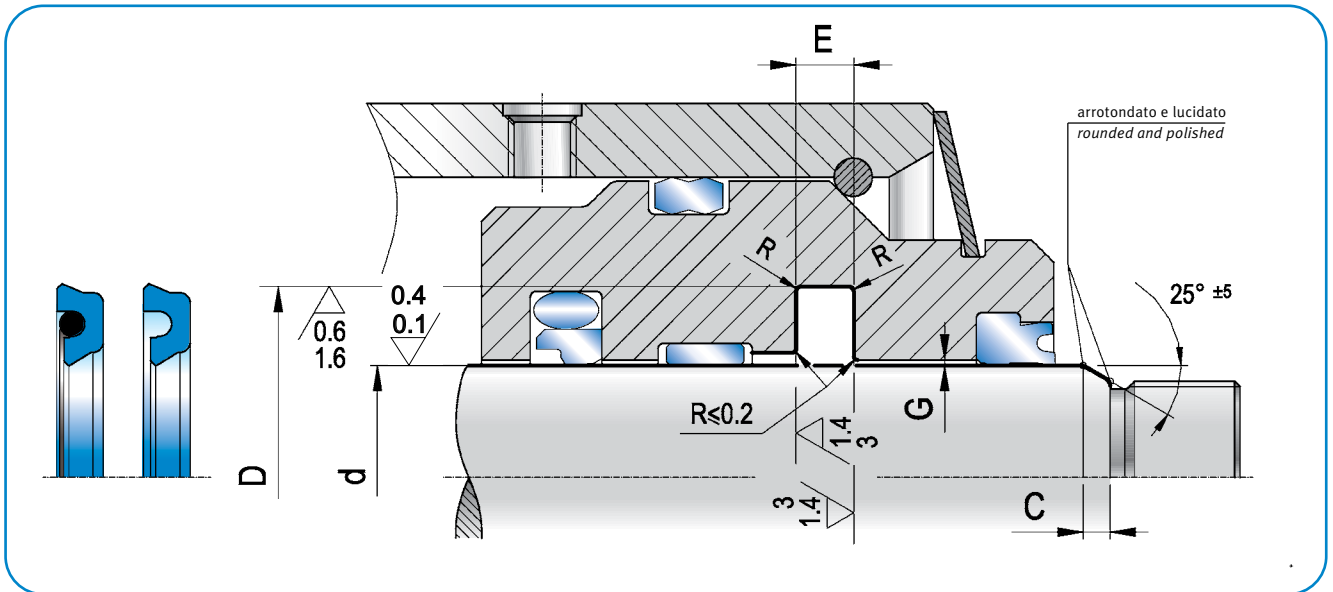
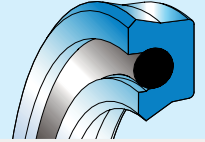

dh ₉	DH ₁₀	E _{+0,2}	R	C	o-ring	ART / ITEM
8,0	15,5	3,0	0,5	3,0	-	RSO 0080 0155 030 Co
* 12,0 ⁽¹⁾	19,5	3,2	0,5	3,0	-	RSO 0120 0195 032 Co
* 14,0 ⁽¹⁾	21,5	3,2	0,5	3,0	-	RSO 0140 0215 032 Co
* 16,0 ⁽¹⁾	23,5	3,2	0,5	3,0	-	RSO 0160 0235 032 Co
* 18,0 ⁽¹⁾	25,5	3,2	0,5	3,0	-	RSO 0180 0255 032 Co
* 20,0 ⁽¹⁾	27,5	3,2	0,5	3,0	-	RSO 0200 0275 032 Co
* 20,0 ⁽²⁾	31,0	4,2	0,5	4,0	OR 119	RSO 0200 0310 042 CN
* 22,0 ⁽¹⁾	29,5	3,2	0,5	3,0	-	RSO 0220 0295 032 Co
* 22,0 ⁽²⁾	33,0	4,2	0,5	4,0	OR 120	RSO 0220 0330 042 CN
* 25,0 ⁽¹⁾	32,5	3,2	0,5	3,0	-	RSO 0250 0325 032 Co
* 25,0 ⁽²⁾	36,0	4,2	0,5	4,0	OR 122	RSO 0250 0360 042 CN
* 26,5 ⁽¹⁾	34,0	3,2	0,5	3,0	-	RSO 0265 0340 032 Co
* 28,0 ⁽²⁾	39,0	4,2	0,5	4,0	OR 124	RSO 0280 0390 042 CN
* 32,0 ⁽²⁾	43,0	4,2	0,5	4,0	OR 127	RSO 0320 0430 042 CN
* 36,0 ⁽²⁾	47,0	4,2	0,5	4,0	OR 129	RSO 0360 0470 042 CN
* 40,0 ⁽²⁾	51,0	4,2	0,5	4,0	OR 132	RSO 0400 0510 042 CN
* 40,0	55,5	6,3	0,9	5,0	OR 224	RSO 0400 0555 063 CN
* 45,0	56,0	4,2	0,5	4,0	OR 135	RSO 0450 0560 042 CN
45,0	60,5	6,3	0,9	5,0	OR 226	RSO 0450 0605 063 CN
* 50,0	61,0	4,2	0,5	4,0	OR 138	RSO 0500 0610 042 CN
50,0	65,5	6,3	0,9	5,0	OR 227	RSO 0500 0655 063 CN
55,0	66,0	4,2	0,5	4,0	OR 141	RSO 0550 0660 042 CN
55,0	70,5	6,3	0,5	4,0	OR 229	RSO 0550 0705 063 CN
* 56,0	67,0	4,2	0,5	4,0	OR 142	RSO 0560 0670 042 CN
* 56,0	71,5	6,3	0,9	5,0	OR 229	RSO 0560 0715 063 CN
* 63,0	74,0	4,2	0,5	4,0	OR 146	RSO 0630 0740 042 CN
* 63,0	78,5	6,3	0,9	5,0	OR 231	RSO 0630 0785 063 CN

dh ₉	DH ₁₀	E _{+0,2}	R	C	o-ring	ART / ITEM
65,0	80,5	6,3	0,9	5,0	OR 232	RSO 0650 0805 063 CN
* 70,0	85,5	6,3	0,9	5,0	OR 234	RSO 0700 0855 063 CN
75,0	86,0	4,2	0,5	4,0	OR 152	RSO 0750 0860 042 CN
75,0	90,5	6,3	0,9	5,0	OR 236	RSO 0750 0905 063 CN
* 80,0	95,5	6,3	0,9	5,0	OR 237	RSO 0800 0955 063 CN
* 90,0	105,5	6,3	0,9	5,0	OR 240	RSO 0900 1055 063 CN
95,0	110,5	6,3	0,9	5,0	OR 242	RSO 0950 1105 063 CN
* 100,0	115,5	6,3	0,9	5,0	OR 243	RSO 1000 1155 063 CN
105,0	120,5	6,3	0,9	5,0	OR 245	RSO 1050 1205 063 CN
110,0	125,5	6,3	0,9	5,0	OR 246	RSO 1100 1255 063 CN
115,0	130,5	6,3	0,9	5,0	OR 248	RSO 1150 1305 063 CN
120,0	135,5	6,3	0,9	5,0	OR 250	RSO 1200 1355 063 CN
130,0	145,5	6,3	0,9	5,0	OR 253	RSO 1300 1455 063 CN
135,0	150,5	6,3	0,9	5,0	OR 255	RSO 1350 1505 063 CN
* 140,0	155,5	6,3	0,9	5,0	OR 256	RSO 1400 1555 063 CN
145,0	160,5	6,3	0,9	5,0	OR 258	RSO 1450 1605 063 CN
150,0	165,5	6,3	0,9	5,0	OR 259	RSO 1500 1655 063 CN
* 160,0	175,5	6,3	0,9	5,0	OR 260	RSO 1600 1755 063 CN
* 160,0	181,0	8,1	0,9	7,0	OR 363	RSO 1600 1810 081 CN
* 180,0	195,5	6,3	0,9	5,0	OR 263	RSO 1800 1955 063 CN
190,0	205,5	6,3	0,9	5,0	OR 265	RSO 1900 2055 063 CN
200,0	215,5	6,3	0,9	5,0	OR 267	RSO 2000 2155 063 CN
* 200,0	221,0	8,1	0,9	7,0	OR 370	RSO 2000 2210 081 CN

Nota: altre dimensioni non a catalogo a richiesta. Consultare il nostro ufficio tecnico.

Remark: please contact our technical dept. for further dimensions not included in the catalogue.

(1) = per RSO con sezione 3,75 mm non viene fornito con o-ring – for cross section 3.75mm RSO is supplied without o-ring

(2) = si consiglia la sede aperta per facilitare montaggio – open groove housing is recommended for easier installation



RBR

BUFFER RING TIPO RBR

Descrizione

L'anello RBR, avente funzione di buffer ring, è stato appositamente progettato come guarnizione primaria per lavorare esclusivamente in tandem con tenute a labbri asimmetrici (v. RSA p. 30).

La sua funzione è quella di permettere alla tenuta secondaria di lavorare comunque in pressione. Non effettuando una tenuta assoluta tra le due guarnizioni si crea una camera d'olio con pressione crescente che si libera, raggiunto un certo valore, all'interno del cilindro grazie al particolare profilo dell'anello RBR. L'insieme funziona come una valvola di massima e ha il compito di contrastare i picchi di pressione.

Dati tecnici

Pressione: < 400 bar a temperature di 60° C
 Velocità: < 0.8 m/s
 Temperatura: da - 35° C a + 100° C con punte fino a 110° C
 Fluidi: oli minerali HL e HLP
 (v. tabella 3 a p.14)

Materiale

Il materiale proposto è il poliuretano tipo Co a 93 Shore A con buona resistenza all'abrasione, ottimo compression-set, elevato modulo elastico necessario per la tenuta.

Per l'anello antiestrusione è proposta una resina termoplastica (L7) con elevata resistenza al carico di rottura.

Codice materiale: CL

Montaggio

Il montaggio avviene in cava chiusa.

Montare prima la guarnizione in poliuretano e poi l'anello antiestrusione.

Per ulteriori informazioni leggere le istruzioni a p. 63.

RBR TYPE BUFFER RING

Description

The RBR ring, working as buffer ring, has been specially designed to work as main seal, to be used in combination with asymmetrical lip seals (see RSA, page 30).

Its function is to maintain working pressure for the second seal. It does not provide full sealing effect so an oil chamber will thus form between the two seals. Thanks to the special profile of the RBR ring, the growing pressure in the space will be released into the cylinder once a certain value is achieved. It works as a valve.

It has been also designed to compensate pressure peaks.

Technical data

Pressure: < 400 bar at a temperature of 60° C
 Speed: < 0.8 m/s
 Temperature: from - 35° C to + 100° C with peaks till 110° C
 Fluids: HL and HLP mineral oil
 (see table 3, page 14)

Material

The proposed material is a "Co" type polyurethane, with high elasticity modulus, fundamental for the sealing, low compression-set and high abrasion resistance.

The hardness is 93 Shore A \pm 2. The material proposed for the anti-extrusion ring is a thermoplastic resin (L7) with high tensile strength.

Compound reference: CL

Assembling

The assembling is done in closed groove. The polyurethane seal must therefore be fitted before the anti-extrusion ring.

For further information please refer to the installation instructions on page 63.



RBR

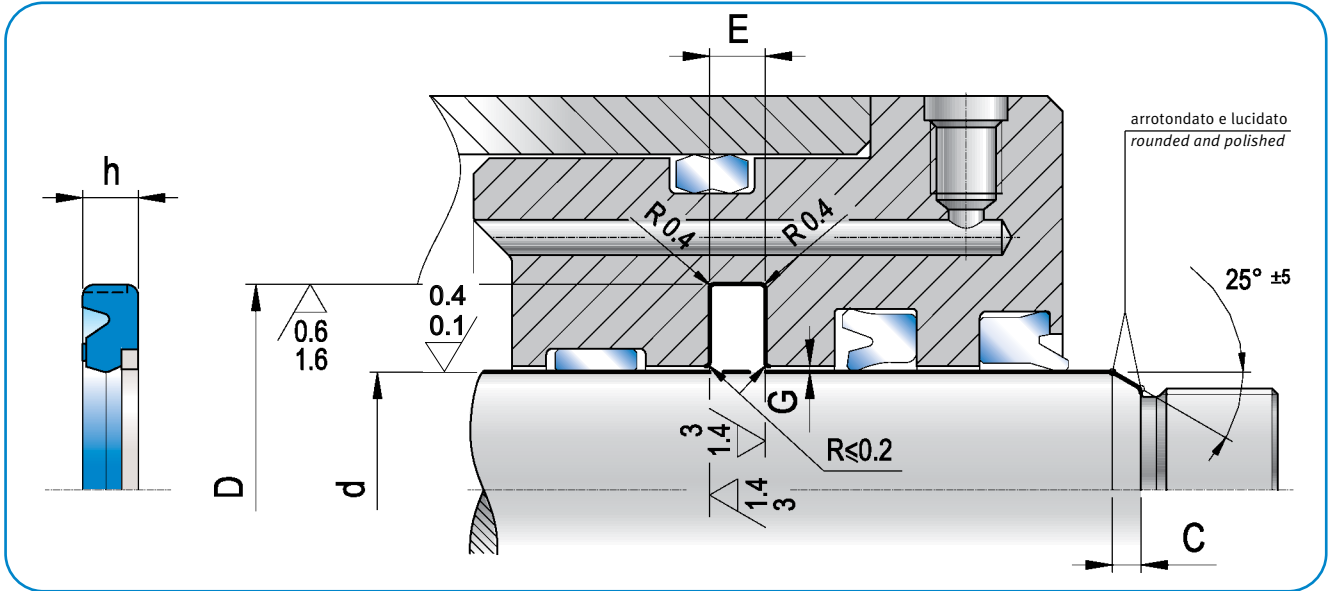
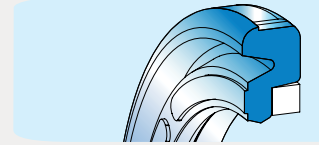

d _{H9}	D _{H10}	h	E _{+0,2}	C	ART / ITEM
45,0	60,5	5,9	6,3	5,5	RBR 0450 0605 063 CL
50,0	65,5	5,9	6,3	5,5	RBR 0500 0655 063 CL
55,0	70,5	5,9	6,3	5,5	RBR 0550 0705 063 CL
56,0	71,5	5,9	6,3	5,5	RBR 0560 0715 063 CL
60,0	75,5	5,9	6,3	5,5	RBR 0600 0755 063 CL
65,0	80,5	5,9	6,3	5,5	RBR 0650 0805 063 CL
63,0	78,5	5,9	6,3	5,5	RBR 0630 0785 063 CL
70,0	85,5	5,9	6,3	6,0	RBR 0700 0855 063 CL
75,0	90,5	5,9	6,3	6,0	RBR 0750 0905 063 CL
80,0	95,5	5,9	6,3	6,0	RBR 0800 0955 063 CL
85,0	100,5	5,9	6,3	6,0	RBR 0850 1005 063 CL
90,0	105,5	5,9	6,3	6,0	RBR 0900 1055 063 CL

d _{H9}	D _{H10}	h	E _{+0,2}	C	ART / ITEM
95,0	110,5	5,9	6,3	6,0	RBR 0950 1105 063 CL
100,0	115,5	5,9	6,3	6,0	RBR 1000 1155 063 CL
105,0	120,5	5,9	6,3	6,0	RBR 1050 1205 063 CL
110,0	125,5	5,9	6,3	6,0	RBR 1100 1255 063 CL
115,0	130,5	5,9	6,3	6,0	RBR 1150 1305 063 CL
120,0	135,5	5,9	6,3	6,0	RBR 1200 1355 063 CL
125,0	140,5	5,9	6,3	6,0	RBR 1250 1405 063 CL
130,0	145,5	5,9	6,3	6,0	RBR 1300 1455 063 CL
150,0	165,5	5,9	6,3	6,0	RBR 1500 1655 063 CL
170,0	185,5	5,9	6,3	6,0	RBR 1700 1855 063 CL
180,0	195,5	5,9	6,3	6,0	RBR 1800 1955 063 CL
200,0	220,5	7,6	8,1	7,5	RBR 2000 2205 081 CL

CL = CO (TPU 93 shore A) + L7 (TPE 72 Shore D)

Nota: altre dimensioni non a catalogo a richiesta. Consultare il nostro ufficio tecnico.

Remark: please contact our technical dept. for further dimensions not included in the catalogue.

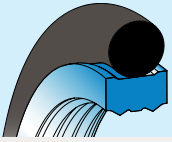

RSS

TENUTA STELO TIPO RSS

Descrizione

La tenuta stelo tipo RSS è stata progettata come guarnizione primaria, a semplice effetto o a doppio effetto.

L'O-ring effettua tenuta statica, allo stesso tempo energizza il pattino in poliuretano, il quale svolge la tenuta dinamica.

Il profilo a doppia cresta, grazie anche all'energizzazione dell'OR, permette la tenuta anche a basse pressioni, mentre il piano centrale del profilo aiuta a mantenere allineato il sistema fornendo un ulteriore punto di appoggio alle guide. Questa tipologia di profilo non consente l'effetto Blow-by, di conseguenza è consigliato esclusivamente l'utilizzo di un raschiatore a unidirezionale.

Dati Tecnici

Pressione:	< 250 bar con materiale standard 93 Shore A a 60°C (Co)
Pressione:	< 400 bar con materiale alternativo 98 Shore A a 60°C (Do)
Pressione:	< 500 bar con materiale alternativo 60 Shore D a 60°C (Eo)
Velocità:	< 0,8 m/s
Temperatura:	da - 30°C a + 110°C, con punte per periodi brevi fino a 120°C.
Fluidi:	fluidi e oli minerali (v. tabella 3 a p. 14)

Materiale

I materiali proposti sono TPU di diverse durezza seconda delle pressioni di esercizio (Co/Do/Eo) O-ring in NBR 70 (No).

Codice materiale: CN (o in alternativa DN/ EN)

Montaggio

Il montaggio avviene in cava anulare chiusa. L'elasticità del materiale favorisce l'inserimento in sede. Togliere le bave di lavorazione per non rovinare la guarnizione. Per ulteriori informazioni leggere le istruzioni a pag. 63

RSS TYPE ROD SEAL

Description

The RSS-type rod seal has been designed as a primary seal, single or double-acting seal.

The O-ring performs a static seal, at the same time energizing the polyurethane slipper, which performs the dynamic seal.

The double peaks profile, thanks also to the energization of the OR, allows the sealing even at low pressures, while the central plane of the profile helps to keep the system aligned, providing an additional support point to the wear rings.

This type of profile doesn't allow the Blow-by effect, therefore it is only recommended to use a unidirectional scraper.

Technical data

Pressure:	< 250 bar with standard material 93 Shore A a 60°C (Co)
Pressure:	< 400 bar with alternative material 98 Shore A a 60°C (Do)
Pressure:	< 500 bar with alternative material 60 Shore D a 60°C (Eo)
Speed:	< 0,8 m/s
Temperature:	from - 30°C up to + 110°C with short peaks till 120°C
Fluid:	mineral fluids and oils (see table 3, page 14)

Material

Material proposed are TPUs with different hardness according to the working pressure O-ring in NBR 70 (No).

Compound reference: CN (or in alternative DN/EN)

Assembling

Installation is in the annular recess closed.

The elasticity of the material favors the inclusion in the seat. Remove burrs from machining, to avoid damaging the seal. For further information please refer to the installation instruction on page 63



RSS

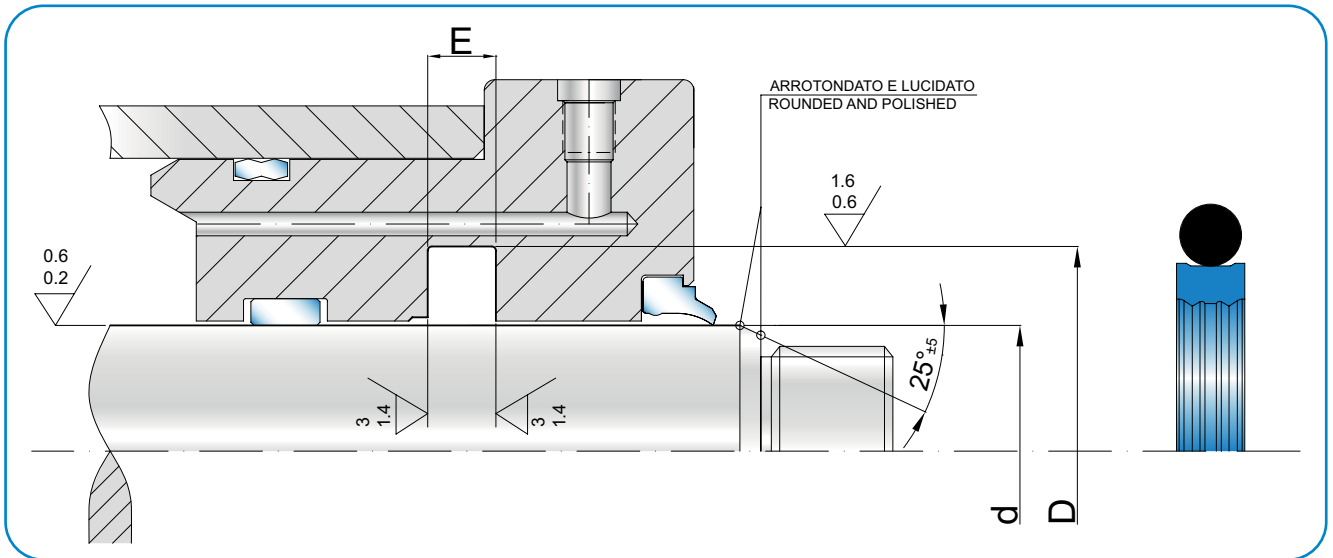
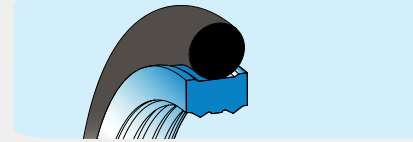

d _{H9}	D _{H9}	E _{+0,2}	O-R	C	ART / ITEM
20,0	30,7	4,20	214	5,0	RSS 0200 0307 042 CN
22,0	32,7	4,20	215	5,0	RSS 0220 0327 042 CN
24,0	34,7	4,20	216	5,0	RSS 0240 0347 042 CN
25,0	32,3	3,20	122	5,0	RSS 0250 0323 032 CN
25,0	35,7	4,20	217	5,0	RSS 0250 0357 042 CN
26,0	36,7	4,20	218	5,0	RSS 0260 0367 042 CN
28,0	38,7	4,20	219	5,0	RSS 0280 0387 042 CN
30,0	40,7	4,20	220	5,0	RSS 0300 0407 042 CN
32,0	42,7	4,20	221	5,0	RSS 0320 0427 042 CN
35,0	45,7	4,20	222	5,0	RSS 0350 0457 042 CN
37,0	47,7	4,20	223	5,0	RSS 0370 0477 042 CN
38,0	53,1	6,30	327	5,0	RSS 0380 0531 063 CN
40,0	50,7	4,20	224	5,0	RSS 0400 0507 042 CN
40,0	55,1	6,30	328	5,0	RSS 0400 0551 063 CN
42,0	52,7	4,20	225	5,0	RSS 0420 0527 042 CN
42,0	57,1	6,30	328	5,0	RSS 0420 0571 063 CN
45,0	55,7	4,20	226	5,0	RSS 0450 0557 042 CN
45,0	60,1	6,30	329	5,0	RSS 0450 0601 063 CN

d _{H9}	D _{H9}	E _{+0,2}	O-R	C	ART / ITEM
48,0	63,1	6,30	330	5,0	RSS 0480 0631 063 CN
50,0	65,1	6,30	331	5,0	RSS 0500 0651 063 CN
52,0	67,1	6,30	331	5,0	RSS 0520 0671 063 CN
52,0	67,1	6,30	331	5,0	RSS 0520 0671 063 CN
55,0	70,1	6,30	332	5,0	RSS 0550 0701 063 CN
58,0	73,1	6,30	333	5,0	RSS 0580 0731 063 CN
60,0	75,1	6,30	334	5,0	RSS 0600 0751 063 CN
65,0	80,1	6,30	335	5,0	RSS 0650 0801 063 CN
70,0	85,1	6,30	337	5,0	RSS 0700 0851 063 CN
75,0	90,1	6,30	339	5,0	RSS 0750 0901 063 CN
80,0	95,1	6,30	340	5,0	RSS 0800 0951 063 CN
85,0	100,1	6,30	342	5,0	RSS 0850 1001 063 CN
90,0	105,1	6,30	343	5,0	RSS 0900 1051 063 CN
95,0	110,1	6,30	345	7,0	RSS 0950 1101 063 CN
100,0	115,1	6,30	346	7,0	RSS 1000 1151 063 CN

Nota: altre dimensioni non a catalogo a richiesta. Consultare il nostro ufficio tecnico.

Remark: please contact our technical dept. for further dimensions not included in the catalogue.

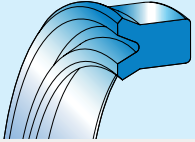

RPS

TENUTA STELO / PISTONE TIPO RPS

Descrizione

La guarnizione tipo RPS, grazie al profilo simmetrico, può essere utilizzata per tenuta su stelo, su pistone e per cilindri che lavorano a semplice o a doppio effetto. Il profilo a labbri uguali e la profondità della gola garantiscono una frizione ridotta e un movimento lineare anche a bassa pressione.

Dati tecnici

Pressione: < 400 bar a temperatura di 60° C
 Velocità: < 0,5 m/s
 Temperatura: da - 35° C a + 100° C con punte fino a 110° C
 Fluidi: oli idraulici minerali
 (v. tabella 3 a p. 14)

Materiali

Il materiale proposto è il poliuretano tipo Co ad alto modulo elastico, basso compression-set e buona resistenza all'abrasione.
 Ha una durezza di 93 Shore A ± 2.
 Codice materiale: Co

Montaggio

Il montaggio è facilitato dall'alto modulo elastico del poliuretano.

- Ingrassare la guarnizione
- togliere spigoli e bave che danneggerebbero la tenuta.

Per ulteriori informazioni leggere le istruzioni a p. 63.

RPS TYPE ROD/PISTON SEAL

Description

The RPS seal type, due to its symmetrical profile, it can be used both for rod and piston sealing applications and for cylinders working with simple or double effect. The profile with equal lips and the deep groove ensures low friction and a linear movement even at low pressure.

Technical data

Pressure: < 400 bar at a temperature of 60° C
 Speed: < 0,5 m/s
 Temperature: from - 35° C to + 100° C, with peaks till + 110° C
 Fluids: mineral hydraulic oils
 (see table 3, page 14)

Material

The proposed material is a "Co" type polyurethane, with high elasticity modulus, fundamental for the sealing, low compression-set and high abrasion resistance. The hardness is 93 Shore A ± 2. Compound reference: Co

Assembling

The high modulus of elasticity of the polyurethane helps the assembling.

- *It is recommended to lubricate the seals before installation*
- *eliminate any edges or flash which could damage the seal.*

For further information please refer to the installation instructions on page 63.

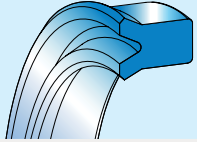

RPS

d_{h11} d_{1h9}	D_{H9} D_{1H10}	h	$E_{+0,2}$	d_2^{**}	C	ART / ITEM
17,0	25,0	10,0	11,0	21,0	3,0	RPS 0170 0250 100 Co
18,0	25,0	5,0	5,5	21,5	3,5	RPS 0180 0250 050 Co
18,0	26,0	6,5	7,5	22,0	3,5	RPS 0180 0260 065 Co
18,0	28,0	6,0	7,0	23,0	4,0	RPS 0180 0280 060 Co
18,0	28,0	8,0	9,0	23,0	4,0	RPS 0180 0280 080 Co
18,0	30,0	8,0	9,0	24,0	5,0	RPS 0180 0300 080 Co
19,0	25,0	6,0	7,0	22,0	3,0	RPS 0190 0250 060 Co
20,0	28,0	4,0	5,0	24,0	3,5	RPS 0200 0280 040 Co
20,0	28,0	4,5	5,0	24,0	3,5	RPS 0200 0280 045 Co
20,0	28,0	5,7	6,0	24,0	3,5	RPS 0200 0280 057 Co
20,0	30,0	8,0	9,0	25,0	4,0	RPS 0200 0300 080 Co
20,0	30,0	10,0	11,0	25,0	4,0	RPS 0200 0300 100 Co
20,0	32,0	7,5	8,5	26,0	5,0	RPS 0200 0320 075 Co
20,0	35,0	12,0	13,0	27,5	5,0	RPS 0200 0350 120 Co
20,0	40,0	10,0	11,0	30,0	7,0	RPS 0200 0400 100 Co
20,0	40,0	12,0	13,0	30,0	7,0	RPS 0200 0400 120 Co
22,0	28,0	4,5	5,5	25,0	3,0	RPS 0220 0280 045 Co
22,0	28,0	8,0	9,0	25,0	3,0	RPS 0220 0280 080 Co
22,0	30,0	6,0	7,0	26,0	3,5	RPS 0220 0300 060 Co
22,0	30,0	10,0	11,0	26,0	3,5	RPS 0220 0300 100 Co
22,0	32,0	8,0	9,0	27,0	4,0	RPS 0220 0320 080 Co
22,0	32,0	10,0	11,0	27,0	4,0	RPS 0220 0320 100 Co
22,0	35,0	10,0	11,0	28,5	5,0	RPS 0220 0350 100 Co
22,0	40,0	10,0	11,0	31,0	6,0	RPS 0220 0400 100 Co
24,0	32,0	4,0	5,0	28,0	3,5	RPS 0240 0320 040 Co
24,0	32,0	7,0	8,0	28,0	3,5	RPS 0240 0320 070 Co
25,0	35,0	5,0	6,0	30,0	4,0	RPS 0250 0350 050 Co
25,0	35,0	8,0	9,0	30,0	4,0	RPS 0250 0350 080 Co
25,0	35,0	10,0	11,0	30,0	4,0	RPS 0250 0350 100 Co
25,0	38,0	10,0	11,0	31,5	5,0	RPS 0250 0380 100 Co
25,0	40,0	10,0	11,0	32,5	5,0	RPS 0250 0400 100 Co
28,0	32,8	3,0	4,0	30,4	3,0	RPS 0280 0328 030 Co
28,0	35,0	5,0	5,5	31,5	3,0	RPS 0280 0350 050 Co
28,0	36,0	5,7	6,3	33,0	4,0	RPS 0280 0360 057 Co
28,0	36,0	6,5	7,5	32,0	3,5	RPS 0280 0360 065 Co
28,0	38,0	5,7	6,3	33,0	4,0	RPS 0280 0380 057 Co
28,0	38,0	8,0	9,0	33,0	4,0	RPS 0280 0380 080 Co
28,0	40,0	10,0	11,0	34,0	5,0	RPS 0280 0400 100 Co
30,0	38,0	6,0	6,5	34,0	4,0	RPS 0300 0380 060 Co
30,0	38,0	7,2	8,0	34,0	4,0	RPS 0300 0380 072 Co
30,0	40,0	5,0	5,5	35,0	5,0	RPS 0300 0400 050 Co
30,0	40,0	7,0	8,0	35,0	5,0	RPS 0300 0400 070 Co
30,0	40,0	10,0	11,0	35,0	5,0	RPS 0300 0400 100 Co
30,0	42,0	9,0	10,0	36,0	5,5	RPS 0300 0420 090 Co
30,0	42,0	10,0	11,0	36,0	5,5	RPS 0300 0420 100 Co

d_{h11} d_{1h9}	D_{H9} D_{1H10}	h	$E_{+0,2}$	d_2^{**}	C	ART / ITEM
30,0	45,0	10,0	11,0	37,5	6,0	RPS 0300 0450 100 Co
30,0	50,0	10,0	11,0	40,0	7,0	RPS 0300 0500 100 Co
30,0	50,0	12,0	13,0	40,0	7,0	RPS 0300 0500 120 Co
32,0	40,0	5,5	6,0	36,0	4,0	RPS 0320 0400 055 Co
32,0	40,0	5,7	6,3	36,0	4,0	RPS 0320 0400 057 Co
32,0	40,0	8,0	9,0	36,0	4,0	RPS 0320 0400 080 Co
32,0	42,0	7,0	8,0	37,0	5,0	RPS 0320 0420 070 Co
32,0	42,0	10,0	11,0	37,0	5,0	RPS 0320 0420 100 Co
32,0	45,0	10,0	11,0	38,5	5,5	RPS 0320 0450 100 Co
32,0	50,0	12,0	13,0	41,0	6,5	RPS 0320 0500 120 Co
35,0	45,0	8,0	9,0	40,0	5,0	RPS 0350 0450 080 Co
35,0	45,0	10,0	11,0	40,0	5,0	RPS 0350 0450 100 Co
35,0	48,0	10,0	11,0	41,5	5,5	RPS 0350 0480 100 Co
35,0	50,0	10,0	11,0	42,5	6,0	RPS 0350 0500 100 Co
35,0	55,0	10,0	11,0	45,0	7,0	RPS 0350 0550 100 Co
36,0	46,0	7,0	8,0	41,0	5,0	RPS 0360 0460 070 Co
38,0	45,0	5,0	5,5	41,5	3,5	RPS 0380 0450 050 Co
38,0	50,0	9,0	10,0	44,0	5,5	RPS 0380 0500 090 Co
38,0	55,0	10,0	11,0	46,5	6,5	RPS 0380 0550 100 Co
40,0	50,0	6,0	7,0	45,0	5,0	RPS 0400 0500 060 Co
40,0	50,0	6,5	7,5	45,0	5,0	RPS 0400 0500 065 Co
40,0	50,0	7,0	8,0	45,0	5,0	RPS 0400 0500 070 Co
40,0	50,0	8,0	9,0	45,0	5,0	RPS 0400 0500 080 Co
40,0	50,0	10,0	11,0	45,0	5,0	RPS 0400 0500 100 Co
40,0	55,0	10,0	11,0	47,5	6,0	RPS 0400 0550 100 Co
40,0	56,0	10,0	11,0	48,0	6,0	RPS 0400 0560 100 Co
40,0	60,0	10,0	11,0	50,0	7,0	RPS 0400 0600 100 Co
40,0	60,0	13,0	14,0	50,0	7,0	RPS 0400 0600 130 Co
42,0	52,0	9,0	10,0	47,0	5,0	RPS 0420 0520 090 Co
45,0	55,0	6,0	7,0	50,0	5,0	RSP 0450 0550 060 Co
45,0	55,0	6,5	7,5	50,0	5,0	RSP 0450 0550 065 Co
45,0	55,0	10,0	11,0	50,0	5,0	RPS 0450 0550 100 Co
45,0	60,0	10,0	11,0	52,5	6,0	RPS 0450 0600 100 Co
45,0	63,0	10,0	11,0	54,0	6,5	RPS 0450 0630 100 Co
45,0	65,0	10,0	11,0	55,0	7,0	RPS 0450 0650 100 Co
45,0	65,0	12,0	13,0	55,0	7,0	RPS 0450 0650 120 Co
48,0	58,0	10,0	11,0	53,0	5,0	RPS 0480 0580 100 Co
50,0	60,0	10,0	11,0	55,0	5,0	RPS 0500 0600 100 Co
50,0	60,0	11,0	12,0	55,0	5,0	RPS 0500 0600 110 Co
50,0	63,0	6,0	7,0	56,5	5,5	RPS 0500 0630 060 Co
50,0	65,0	10,0	11,0	57,5	6,0	RPS 0500 0650 100 Co
50,0	70,0	10,0	11,0	60,0	7,0	RPS 0500 0700 100 Co
50,0	70,0	12,0	13,0	60,0	7,0	RPS 0500 0700 120 Co
52,0	57,0	2,5	3,0	54,5	5,0	RPS 0520 0570 025 Co
53,0	63,0	6,5	7,5	58,0	5,0	RPS 0530 0630 065 Co



RPS

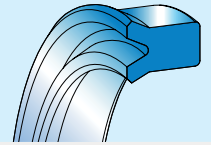

d_{h11} d_{1h9}	D_{H9} D_{1H10}	h	$E_{+0,2}$	d_2^{**}	C	ART / ITEM
55,0	65,0	10,0	11,0	60,0	5,0	RPS 0550 0650 100 Co
55,0	65,0	12,0	13,0	60,0	5,0	RPS 0550 0650 120 Co
55,0	70,0	12,0	13,0	62,5	6,0	RPS 0550 0700 120 Co
55,0	75,0	12,0	13,0	65,0	7,0	RPS 0550 0750 120 Co
56,0	66,0	10,0	11,0	61,0	5,0	RPS 0560 0660 100 Co
56,0	68,0	7,0	8,0	62,0	5,0	RPS 0560 0680 070 Co
56,0	71,0	10,0	11,0	63,5	6,0	RPS 0560 0710 100 Co
60,0	68,0	8,0	9,0	64,0	5,0	RPS 0600 0680 080 Co
60,0	70,0	6,0	7,0	65,0	5,0	RPS 0600 0700 060 Co
60,0	70,0	8,0	9,0	65,0	5,0	RPS 0600 0700 080 Co
60,0	70,0	10,0	11,0	65,0	5,0	RPS 0600 0700 100 Co
60,0	70,0	12,0	13,0	65,0	5,0	RPS 0600 0700 120 Co
60,0	75,0	10,0	11,0	67,5	6,0	RPS 0600 0750 100 Co
60,0	75,0	12,0	13,0	67,5	6,0	RPS 0600 0750 120 Co
60,0	80,0	10,0	11,0	70,0	7,0	RPS 0600 0800 100 Co
60,0	80,0	12,0	13,0	70,0	7,0	RPS 0600 0800 120 Co
63,0	75,0	10,0	11,0	69,0	5,5	RPS 0630 0750 100 Co
63,0	78,0	10,0	11,0	70,5	6,0	RPS 0630 0780 100 Co
63,0	80,0	10,0	11,0	71,5	6,5	RPS 0630 0800 100 Co
65,0	75,0	12,0	13,0	70,0	5,0	RPS 0650 0750 120 Co
65,0	80,0	10,0	11,0	72,5	6,0	RPS 0650 0800 100 Co
65,0	80,0	11,0	12,0	72,5	6,0	RPS 0650 0800 110 Co
65,0	80,0	12,0	13,0	72,5	6,0	RPS 0650 0800 120 Co
65,0	85,0	10,0	11,0	75,0	7,0	RPS 0650 0850 100 Co
65,0	85,0	12,0	13,0	75,0	7,0	RPS 0650 0850 120 Co
66,0	76,0	8,0	9,0	71,0	5,0	RPS 0660 0760 080 Co
67,0	77,0	12,0	13,0	72,0	5,0	RPS 0670 0770 120 Co
70,0	80,0	7,0	8,0	75,0	5,0	RPS 0700 0800 070 Co
70,0	80,0	8,0	9,0	75,0	5,0	RPS 0700 0800 080 Co
70,0	80,0	10,0	11,0	75,0	5,0	RPS 0700 0800 100 Co
70,0	80,0	12,0	13,0	75,0	5,0	RPS 0700 0800 120 Co
70,0	85,0	10,0	11,0	77,5	6,0	RPS 0700 0850 100 Co
70,0	85,0	12,0	13,0	77,5	6,0	RPS 0700 0850 120 Co
70,0	90,0	10,0	11,0	80,0	7,0	RPS 0700 0900 100 Co
70,0	90,0	12,0	13,0	80,0	7,0	RPS 0700 0900 120 Co
75,0	85,0	10,0	11,0	80,0	5,0	RPS 0750 0850 100 Co
75,0	85,0	12,0	13,0	80,0	5,0	RPS 0750 0850 120 Co
75,0	90,0	10,0	11,0	82,5	6,0	RPS 0750 0900 100 Co
75,0	90,0	12,0	13,0	82,5	6,0	RPS 0750 0900 120 Co
75,0	95,0	12,0	13,0	85,0	7,0	RPS 0750 0950 120 Co
75,0	95,0	13,5	14,5	85,0	7,0	RPS 0750 0950 135 Co
80,0	90,0	7,0	8,0	85,0	5,0	RPS 0800 0900 070 Co

d_{h11} d_{1h9}	D_{H9} D_{1H10}	h	$E_{+0,2}$	d_2^{**}	C	ART / ITEM
80,0	90,0	10,0	11,0	85,0	5,0	RPS 0800 0900 100 Co
80,0	90,0	12,0	13,0	85,0	5,0	RPS 0800 0900 120 Co
80,0	95,0	12,0	13,0	87,5	6,0	RPS 0800 0950 120 Co
80,0	100,0	10,0	11,0	90,0	7,0	RPS 0800 1000 100 Co
80,0	100,0	12,0	13,0	90,0	7,0	RPS 0800 1000 120 Co
85,0	95,0	8,5	9,5	90,0	5,0	RPS 0850 0950 085 Co
85,0	95,0	12,0	13,0	90,0	5,0	RPS 0850 0950 120 Co
85,0	100,0	9,0	10,0	92,5	6,0	RPS 0850 1000 090 Co
85,0	100,0	12,0	13,0	92,5	6,0	RPS 0850 1000 120 Co
85,0	105,0	12,0	13,0	95,0	7,0	RPS 0850 1050 120 Co
90,0	100,0	7,0	8,0	95,0	5,0	RPS 0900 1000 070 Co
90,0	100,0	8,0	9,0	95,0	5,0	RPS 0900 1000 080 Co
90,0	100,0	10,5	11,5	95,0	5,0	RPS 0900 1000 105 Co
90,0	100,0	12,0	13,0	95,0	5,0	RPS 0900 1000 120 Co
90,0	105,0	12,0	13,0	97,5	6,0	RPS 0900 1050 120 Co
90,0	110,0	12,0	13,0	100,0	7,0	RPS 0900 1100 120 Co
90,0	110,0	18,0	19,0	100,0	7,0	RPS 0900 1100 180 Co
95,0	105,0	12,0	13,0	100,0	5,0	RPS 0950 1050 120 Co
95,0	110,0	12,0	13,0	102,5	6,0	RPS 0950 1100 120 Co
95,0	110,0	12,5	13,5	102,5	6,0	RPS 0950 1100 125 Co
95,0	110,0	15,0	16,0	102,5	6,0	RPS 0950 1100 150 Co
95,0	112,0	11,0	12,0	103,5	6,5	RPS 0950 1120 110 Co
95,0	115,0	12,0	13,0	105,0	7,0	RPS 0950 1150 120 Co
95,0	115,0	18,0	19,0	105,0	7,0	RPS 0950 1150 180 Co
100,0	115,0	12,0	13,0	107,5	6,0	RPS 1000 1150 120 Co
100,0	120,0	12,0	13,0	110,0	7,0	RPS 1000 1200 120 Co
100,0	120,0	15,0	14,0	110,0	7,0	RPS 1000 1200 150 Co
100,0	125,0	15,0	16,0	112,5	8,0	RPS 1000 1250 150 Co
105,0	125,0	12,0	13,0	115,0	7,0	RPS 1050 1250 120 Co
105,0	125,0	15,0	16,0	115,0	7,0	RPS 1050 1250 150 Co
110,0	130,0	15,0	16,0	120,0	7,0	RPS 1100 1300 150 Co
120,0	140,0	12,0	13,0	130,0	7,0	RPS 1200 1400 120 Co
120,0	140,0	15,0	16,0	130,0	7,0	RPS 1200 1400 150 Co
125,0	140,0	15,0	16,0	132,5	6,0	RPS 1250 1400 150 Co
130,0	150,0	15,0	16,0	140,0	7,0	RPS 1300 1500 150 Co
170,0	190,0	15,0	16,0	180,0	7,0	RPS 1700 1900 150 Co
200,0	220,0	12,0	13,0	210,0	7,0	RPS 2000 2200 120 Co

Per diametri superiori a 200mm sono disponibili le tenute tipo MAD e tipo CSC della Macma, programma dimensioni a pag. 328.
Seals type MAD and type CSC, produced by Macma, are available for diameters bigger than 200 mm, program range at page 328

* in conformità alle norme ISO/DIN 5597 e ISO 5597/1 – in accordance with ISO/DIN 5597 and ISO 5597/1 norms

** diametro di aggancio consigliato ma modificabile in funzione delle esigenze di montaggio – hook diameter which could be modified according to mounting demand

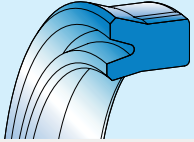

PSA

TENUTA PISTONE TIPO PSA

Descrizione

La guarnizione tipo PSA è stata realizzata per impieghi su pistone e può essere utilizzata sia per il semplice sia per il doppio effetto. Ha labbri asimmetrici che assicurano sempre il contatto con la camicia anche in presenza di disallineamenti elevati. Grazie all'alto modulo elastico del materiale, il montaggio avviene in cava semiaperta.

Dati tecnici

Pressione: < 400 bar a temperatura di 60° C
 Velocità: < 0.5 m/s
 Temperatura: da - 35° C a + 100° C con punte fino a 110° C
 Fluidi: oli a base minerale
 (v. tabella 3 a p. 14)

Materiale

Il materiale proposto è il poliuretano tipo Co ad alto modulo elastico, basso compression-set ed alta resistenza all'usura.
 Ha una durezza di 93 Shore A ± 2.
 Codice materiale: Co

Montaggio

- Lubrificare la tenuta prima del montaggio
- eliminare tutti gli spigoli vivi e le bave sul pistone dove alloggia la guarnizione
- eseguire uno smusso di invito sulla camicia per facilitare l'inserimento del pistone.

Per ulteriori informazioni leggere le istruzioni a p. 63.

PSA TYPE PISTON SEAL

Description

The PSA seal type has been conceived to work on the piston and it can be used for simple or double effect. Its has asymmetrical lips which ensure a continuous contact with the bore, even in case of high misalignments.
 Elastic installation in semi-open groove thanks to the high elastic modulus of the material.

Technical data

Pressure: < 400 bar at a temperature of 60° C
 Speed: < 0.5 m/s
 Temperature: from - 35° C to + 100° C, with peaks till 110° C
 Fluids: mineral-based oils and fuels
 (see table 3, page 14)

Material

The material used is a polyurethane with a high modulus of elasticity, low compression set and high wear resistance.
 Its hardness is 93 Shore A ± 2.
 Compound reference: Co

Assembling

Remove any flash or cutting edges on the piston where the seal is housed.
 Provide a lead-in chamfer in the bore to have an easier piston insertion.
 Lubricate the packing before installation.
 For further information please refer to the installation instructions on page 63.



PSA

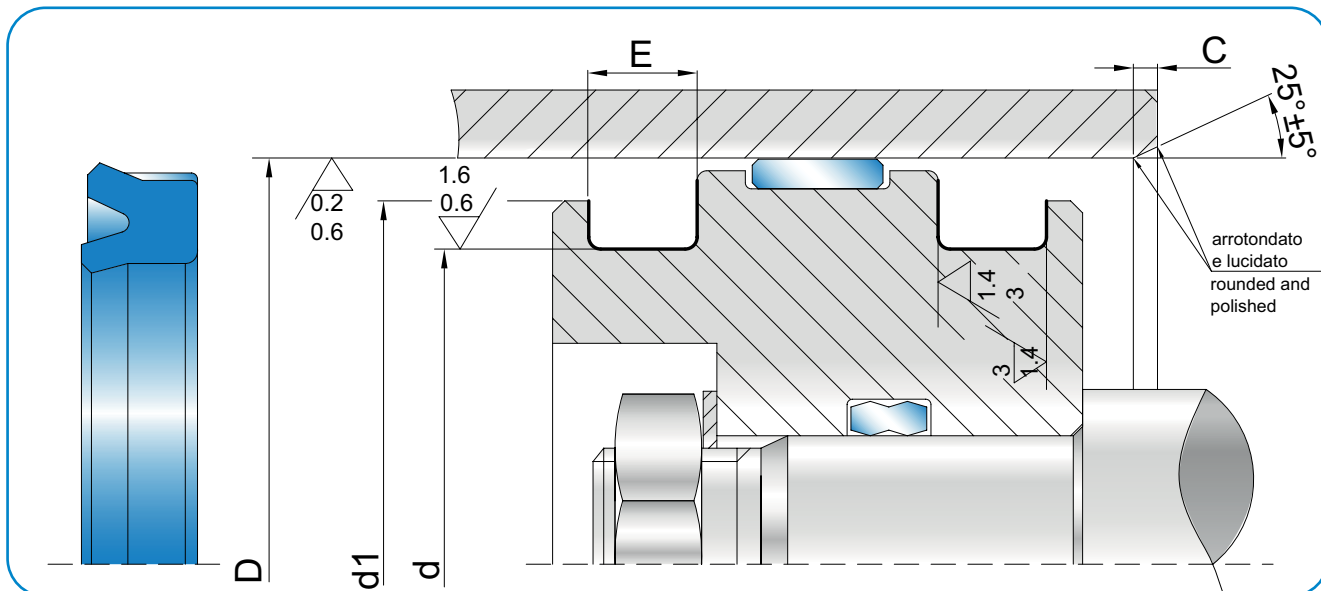
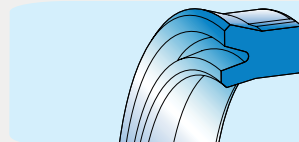

Oleodinamica
Hydraulic

D _{H9}	dh ₉	h	E _{+0,2}	d ₁ *	C	ART / ITEM
20,0	12,0	6,5	7,5	15,0	4,0	PSA 0200 0120 065 Co
20,0	14,0	5,5	6,0	17,0	3,5	PSA 0200 0140 055 Co
22,0	12,0	8,0	9,0	16,0	5,0	PSA 0220 0120 080 Co
22,0	14,0	5,0	5,5	16,0	5,0	PSA 0220 0140 050 Co
25,0	15,0	8,0	9,0	19,0	5,0	PSA 0250 0150 080 Co
25,0	18,0	5,0	6,0	22,0	5,0	PSA 0250 0180 050 Co
28,0	20,0	7,0	8,0	24,0	5,0	PSA 0280 0200 070 Co
30,0	20,0	8,0	9,0	24,0	5,0	PSA 0300 0200 080 Co
30,0	22,0	6,5	7,0	26,0	5,0	PSA 0300 0220 065 Co
32,0	19,3	7,0	8,0	21,3	5,0	PSA 0320 0193 070 Co
32,0	22,0	10,0	11,0	26,0	5,0	PSA 0320 0220 100 Co
32,0	24,0	5,7	6,3	28,0	4,0	PSA 0320 0240 057 Co
32,0	26,0	5,0	6,0	28,0	3,5	PSA 0320 0260 050 Co
34,0	28,0	5,0	6,0	32,0	3,5	PSA 0340 0280 050 Co
35,0	20,0	10,0	11,0	25,0	5,5	PSA 0350 0200 100 Co
35,0	25,0	8,0	9,0	29,0	5,0	PSA 0350 0250 080 Co
37,0	21,0	12,0	13,0	25,0	6,0	PSA 0370 0210 120 Co
40,0	25,0	10,0	11,0	30,0	6,0	PSA 0400 0250 100 Co
40,0	27,3	7,0	8,0	29,3	5,0	PSA 0400 0273 070 Co
40,0	30,0	6,5	7,5	34,0	5,0	PSA 0400 0300 065 Co
40,0	30,0	10,0	11,0	34,0	5,0	PSA 0400 0300 100 Co
40,0	32,0	5,5	6,5	36,0	4,0	PSA 0400 0320 055 Co
40,0	32,0	4,0	5,0	36,0	4,0	PSA 0400 0320 040 Co
40,0	32,0	8,0	9,0	36,0	4,0	PSA 0400 0320 080 Co
42,0	32,0	10,0	11,0	36,0	5,0	PSA 0420 0320 100 Co
45,0	30,0	10,0	11,0	35,0	6,0	PSA 0450 0300 100 Co
45,0	30,0	12,0	13,0	35,0	6,0	PSA 0450 0300 120 Co

* diametro di aggancio consigliato ma modificabile in funzione delle esigenze di montaggio

* recommended hook diameter which could be modified according to mounting demand

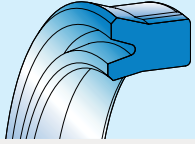

PSA

D _{H9}	d _{h9}	h	E _{+0,2}	d ₁ *	C	ART / ITEM				
50,0	30,0	12,0	13,0	35,0	7,0	PSA	0500	0300	120	Co
50,0	32,0	10,0	11,0	37,0	6,5	PSA	0500	0320	100	Co
50,0	35,0	8,5	9,5	40,0	6,0	PSA	0500	0350	085	Co
50,0	35,0	10,0	11,0	40,0	6,0	PSA	0500	0350	100	Co
50,0	35,0	12,0	13,0	40,0	6,0	PSA	0500	0350	120	Co
50,0	40,0	5,0	5,5	44,0	5,0	PSA	0500	0400	050	Co
50,0	40,0	7,3	8,0	44,0	5,0	PSA	0500	0400	073	Co
50,0	40,0	10,0	11,0	44,0	5,0	PSA	0500	0400	100	Co
50,0	42,0	5,5	6,0	45,0	4,0	PSA	0500	0420	055	Co
50,0	42,0	8,0	9,0	45,0	4,0	PSA	0500	0420	080	Co
55,0	40,0	10,0	11,0	45,0	6,0	PSA	0550	0400	100	Co
56,0	45,0	7,0	8,0	50,0	6,0	PSA	0560	0450	040	Co
60,0	40,0	12,0	13,0	45,0	7,0	PSA	0600	0400	120	Co
60,0	45,0	10,0	11,0	50,0	6,0	PSA	0600	0450	100	Co
60,0	45,0	12,0	13,0	50,0	6,0	PSA	0600	0450	120	Co
60,0	50,0	7,0	8,0	54,0	5,0	PSA	0600	0500	070	Co
60,0	50,0	10,0	11,0	54,0	5,0	PSA	0600	0500	100	Co
63,0	43,0	12,0	13,0	47,0	7,0	PSA	0630	0430	120	Co
63,0	45,0	12,0	13,0	50,0	6,0	PSA	0630	0450	120	Co
63,0	48,0	6,5	7,5	53,0	6,5	PSA	0630	0480	065	Co
63,0	48,0	10,0	11,0	53,0	6,0	PSA	0630	0480	100	Co
63,0	48,0	12,0	13,0	53,0	6,0	PSA	0630	0480	120	Co
63,0	53,0	6,0	7,0	57,0	5,0	PSA	0630	0530	060	Co
63,0	53,0	7,0	8,0	57,0	5,0	PSA	0630	0530	070	Co
63,0	53,0	12,0	13,0	57,0	5,0	PSA	0630	0530	120	Co
65,0	45,0	12,0	13,0	50,0	7,0	PSA	0650	0450	120	Co
65,0	50,0	10,0	11,0	55,0	6,0	PSA	0650	0500	100	Co
65,0	50,0	12,0	13,0	55,0	6,0	PSA	0650	0500	120	Co
70,0	40,0	11,0	12,0	45,0	7,0	PSA	0700	0400	110	Co
70,0	50,0	12,0	13,0	55,0	7,0	PSA	0700	0500	120	Co
70,0	55,0	9,5	10,5	60,0	6,0	PSA	0700	0550	095	Co
70,0	55,0	12,0	13,0	60,0	6,0	PSA	0700	0550	120	Co
70,0	60,0	6,0	7,0	64,0	5,0	PSA	0700	0600	060	Co
70,0	60,0	7,0	8,0	64,0	5,0	PSA	0700	0600	070	Co
70,0	60,0	12,0	13,0	64,0	5,0	PSA	0700	0600	120	Co
70,0	62,0	7,5	8,5	65,0	4,5	PSA	0700	0620	075	Co
75,0	55,0	13,5	14,5	60,0	7,0	PSA	0750	0550	135	Co
75,0	65,0	7,0	8,0	69,0	5,0	PSA	0750	0650	070	Co
75,0	65,0	10,0	11,0	69,0	5,0	PSA	0750	0650	100	Co
80,0	60,0	12,0	13,0	65,0	7,0	PSA	0800	0600	120	Co
80,0	64,0	12,0	13,0	69,0	6,0	PSA	0800	0640	120	Co
80,0	65,0	12,0	13,0	70,0	6,0	PSA	0800	0650	120	Co
80,0	68,0	8,5	9,5	72,0	5,5	PSA	0800	0680	085	Co
80,0	70,0	6,0	7,0	74,0	5,0	PSA	0800	0700	060	Co
80,0	70,0	7,0	8,0	74,0	5,0	PSA	0800	0700	070	Co



PSA

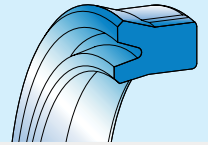

D _{H9}	d _{H9}	h	E _{+0,2}	d ₁ *	C	ART / ITEM				
80,0	70,0	12,0	13,0	74,0	5,0	PSA	0800	0700	120	Co
85,0	65,0	12,0	13,0	70,0	7,0	PSA	0850	0650	120	Co
85,0	65,0	13,5	14,5	70,0	7,0	PSA	0850	0650	135	Co
85,0	70,0	12,0	13,0	75,0	6,0	PSA	0850	0700	120	Co
85,0	75,0	10,0	11,0	79,0	5,0	PSA	0850	0750	100	Co
90,0	70,0	12,0	13,0	75,0	7,0	PSA	0900	0700	120	Co
90,0	70,0	13,5	14,5	75,0	7,0	PSA	0900	0700	135	Co
90,0	75,0	12,0	13,0	80,0	6,0	PSA	0900	0750	120	Co
90,0	80,0	10,0	11,0	84,0	5,0	PSA	0900	0800	100	Co
95,0	80,0	12,0	13,0	85,0	6,0	PSA	0950	0800	120	Co
95,0	85,0	7,0	8,0	89,0	5,0	PSA	0950	0850	070	Co
100,0	80,0	10,0	11,0	85,0	7,0	PSA	1000	0800	100	Co
100,0	80,0	12,0	13,0	85,0	7,0	PSA	1000	0800	120	Co
100,0	85,0	12,0	13,0	90,0	6,0	PSA	1000	0850	120	Co
100,0	88,0	8,5	9,5	93,0	5,5	PSA	1000	0880	085	Co
100,0	90,0	7,0	8,0	94,0	5,0	PSA	1000	0900	070	Co
100,0	90,0	8,0	9,0	94,0	5,0	PSA	1000	0900	080	Co
105,0	90,0	12,0	13,0	95,0	6,0	PSA	1050	0900	120	Co
110,0	90,0	12,0	13,0	95,0	7,0	PSA	1100	0900	120	Co
110,0	95,0	12,0	13,0	100,0	6,0	PSA	1100	0950	120	Co
110,0	100,0	8,0	9,0	105,0	6,0	PSA	1100	1000	080	Co
115,0	95,0	15,0	16,0	105,0	7,0	PSA	1150	0950	150	Co
115,0	100,0	12,0	13,0	105,0	6,0	PSA	1150	1000	120	Co
120,0	100,0	12,0	13,0	105,0	7,0	PSA	1200	1000	120	Co
120,0	105,0	12,0	13,0	110,0	6,0	PSA	1200	1050	120	Co
125,0	100,0	15,0	16,0	105,0	8,0	PSA	1250	1000	150	Co
125,0	105,0	12,0	13,0	110,0	7,0	PSA	1250	1050	120	Co
125,0	105,0	15,0	16,0	110,0	7,0	PSA	1250	1050	150	Co
125,0	110,0	10,0	11,0	115,0	6,0	PSA	1250	1100	100	Co
130,0	110,0	15,0	16,0	115,0	7,0	PSA	1300	1100	150	Co
140,0	120,0	12,0	13,0	125,0	7,0	PSA	1400	1200	120	Co
140,0	120,0	15,0	16,0	125,0	7,0	PSA	1400	1200	150	Co
150,0	130,0	15,0	16,0	135,0	7,0	PSA	1500	1300	150	Co
160,0	140,0	11,5	12,5	145,0	7,0	PSA	1600	1400	115	Co
160,0	140,0	15,0	16,0	145,0	7,0	PSA	1600	1400	150	Co
180,0	160,0	11,5	12,5	165,0	7,0	PSA	1800	1600	115	Co
180,0	160,0	15,0	16,0	165,0	7,0	PSA	1800	1600	150	Co
200,0	170,0	19,0	20,0	175,0	8,0	PSA	2000	1700	190	Co
200,0	180,0	12,0	13,0	185,0	8,0	PSA	2000	1800	120	Co
220,0	200,0	15,0	16,0	205,0	8,0	PSA	2200	2000	150	Co
250,0	220,0	19,0	20,0	225,0	8,0	PSA	2500	2200	190	Co

* diametro di aggancio consigliato ma modificabile in funzione delle esigenze di montaggio

* recommended hook diameter which could be modified according to mounting demand

Nota: altre dimensioni non a catalogo a richiesta. Consultare il nostro ufficio tecnico.

Remark: please contact our technical dept. for further dimensions not included in the catalogue.

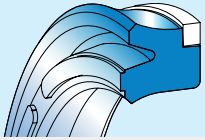

PAE

TENUTA PISTONE CON ANELLO ANTIESTRUSIONE TIPO PAE

Descrizione

La guarnizione tipo PAE è stata realizzata specificatamente per operare in condizioni di esercizio molto gravose.

Quando i giochi di accoppiamento tra camicia e pistone non possono essere ridotti e la pressione è molto elevata, superiore a 250 bar, la tenuta tipo PAE, grazie ad un robusto anello antiestrusione, risulta tra le più appropriate.

Dati tecnici

Pressione: < 400 bar a temperatura di 60° C

Velocità: < 0.5 m/s

Temperatura: da - 35° C a +100° C con punte fino a 110° C

Fluidi: oli a base minerale (v. tabella 3 a p. 14)

Materiale

I materiali utilizzati sono un poliuretano tipo Co a 93 Shore A ad alto modulo elastico per la guarnizione e una resina acetica, tipo Ro rinforzata con fibre di vetro con elevata resistenza al carico di rottura, per l'anello antiestrusione.

Codice materiale: CR

Montaggio

- Lubrificare la tenuta prima del montaggio che avviene in cava semiaperta
- montare la tenuta e poi l'anello antiestrusione
- togliere le bave e gli spigoli vivi sul pistone per non danneggiare la guarnizione durante il montaggio nella fase di accavallamento.

Per ulteriori informazioni leggere le istruzioni a p. 63

PAE TYPE PISTON SEAL WITH ANTIEXTRUSION RING

Description

The PAE seal type is specially designed for heavy duty applications.

When the coupling clearance between bore and piston cannot be reduced and the pressure is very high - above 250 bar - the PAE seal type, thanks to a strong anti-extrusion ring, is among the most appropriate of seal types.

Technical data

Pressure: < 400 bar at a temperature of 60° C

Speed: < 0.5 m/s

Temperature: from - 35° C till +100° C

Fluids: mineral oils
(see table 3, page 14)

Material

The material used for the seal is polyurethane Co-type at 93 Shore A with high elasticity module. The anti-extrusion ring is made of acetal resin Ro-type reinforced with fibreglass and with high tensile strength.

Compound reference: CR

Assembling

- The assembling of this seal is done in semi-open groove
- the anti-extrusion ring should be installed after the seal
- It is important to remove any flash or cutting edge on the piston not to damage the seal during the overlapping.
- Lubricate the packing before installation.

For further information please refer to the installation instructions on page 63.



PAE

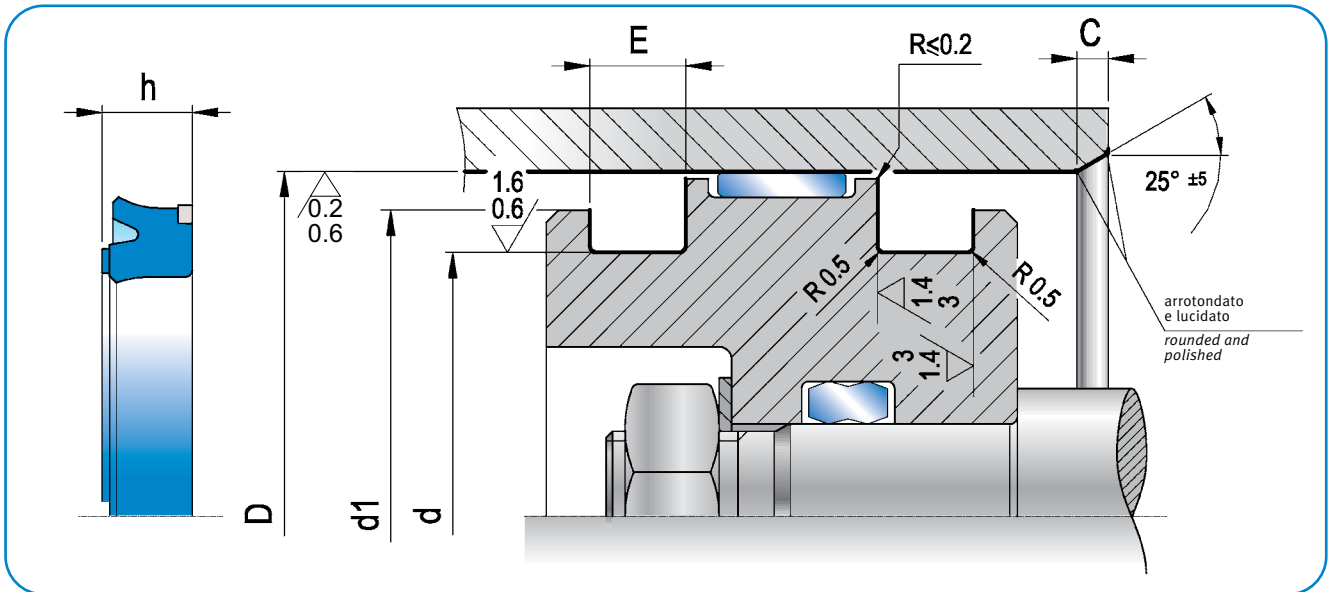
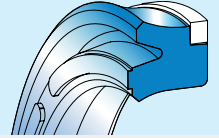

D _{H9}	d _{H9}	d ₁ *	h	E _{+0,2}	C	ART / ITEM
40,0	25,0	35,0	9,3	9,5	4,0	PAE 0400 0250 093 CR
45,0	30,0	40,0	9,3	9,5	4,0	PAE 0450 0300 093 CR
50,0	35,0	45,0	9,3	9,5	4,0	PAE 0500 0350 093 CR
55,0	40,0	50,0	9,3	9,5	4,0	PAE 0550 0400 093 CR
60,0	45,0	55,0	9,3	9,5	4,0	PAE 0600 0450 093 CR
63,0	48,0	58,0	9,3	9,5	4,0	PAE 0630 0480 093 CR
65,0	50,0	60,0	9,3	9,5	4,0	PAE 0650 0500 093 CR
70,0	50,0	64,0	12,2	12,5	5,0	PAE 0700 0500 122 CR
75,0	55,0	69,0	12,2	12,5	5,0	PAE 0750 0550 122 CR
80,0	60,0	74,0	12,2	12,5	5,0	PAE 0800 0600 122 CR
85,0	70,0	80,0	9,3	9,5	4,0	PAE 0850 0700 093 CR
90,0	70,0	84,0	12,2	12,5	5,0	PAE 0900 0700 122 CR

D _{H9}	d _{H9}	d ₁ *	h	E _{+0,2}	C	ART / ITEM
100,0	80,0	94,0	12,2	12,5	5,0	PAE 1000 0800 122 CR
105,0	85,0	99,0	12,2	12,5	5,0	PAE 1050 0850 122 CR
110,0	90,0	104,0	12,2	12,5	5,0	PAE 1100 0900 122 CR
115,0	95,0	109,0	12,2	12,5	5,0	PAE 1150 0950 122 CR
125,0	100,0	117,0	15,2	16,2	6,5	PAE 1250 1000 152 CR
125,0	105,0	119,0	12,2	12,5	5,0	PAE 1250 1050 122 CR
130,0	110,0	124,0	12,2	12,5	5,0	PAE 1300 1100 122 CR
140,0	115,0	132,0	15,2	16,2	6,5	PAE 1400 1150 152 CR
140,0	120,0	134,0	12,2	12,5	5,0	PAE 1400 1200 122 CR

* diametro di aggancio consigliato ma modificabile in funzione delle esigenze di montaggio

* recommended hook diameter which could be modified according to mounting demand

Nota: altre dimensioni non a catalogo a richiesta. Consultare il nostro ufficio tecnico.

Remark: please contact our technical dept. for further dimensions not included in the catalogue.

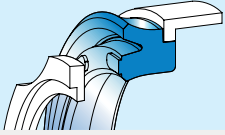

PSH + RR

TENUTA PISTONE CON ANELLO GUIDA E RITEGNO TIPO PSH + RR

Descrizione

La guarnizione per pistone tipo PSH è simile al tipo PSA ma è provvista di un anello di guida in resina acetale che attenua eventuali disallineamenti e funge da antiestrusione. Un anello di ritegno tipo RR in resina termoplastica previene l'espulsione della tenuta durante l'inversione del ciclo.

Dati tecnici

Pressione: < 400 bar a temperatura di 60° C
 Velocità: < 0.5 m/s
 Temperatura: da - 35° C a + 100° C con punte fino a +110° C
 Fluidi: fluidi e oli a base minerale
 (v. tabella 3 a p. 14)

Materiale

Il materiale proposto è il poliuretano tipo Co ad alto modulo elastico, a basso compression-set ed elevata resistenza all'abrasione; l'anello di guida è in resina acetale tipo Ro rinforzata con fibre di vetro.

Codice materiale PSH: CR

L'anello di ritegno è costruito in resina termoplastica tipo R2.

Codice materiale RR: R2

Montaggio

- Lubrificare la tenuta prima del montaggio
- eliminare tutti gli spigoli vivi e le bave sul pistone dove alloggia la guarnizione
- eseguire uno smusso di invito sulla camicia per facilitare l'inserimento del pistone.

Per ulteriori informazioni leggere le istruzioni a p. 63

PSH+RR TYPE PISTON SEAL WITH WEAR AND RETAINING RING

Description

The PSH piston seal type is similar to the PSA type, but it has an acetal resin wear ring to mitigate possible misalignments and avoid extrusion. A RR retaining ring made of thermoplastic resin prevents seal ejection during the cycle inversion.

Technical data

Pressure: < 400 bar at a temperature of 60° C
 Speed: < 0.5 m/s
 Temperature: from - 35° C to + 100° C with peaks till +110° C
 Fluids: mineral fluids and oils
 (see table 3, page 14)

Material

The proposed material is a Co-type polyurethane with high modulus of elasticity, low compression set and high abrasion resistance. The wear ring is made of a Ro-type acetal resin reinforced with fibreglass.

Compound reference PSH: CR

The retaining seal is made of thermoplastic resin, R2 type.

Compound reference RR: R2

Assembling

- Avoid all cutting edges and flash on the piston where the seal is housed
- a lead-in chamfer in the groove will facilitate the piston insertion
- lubricate the seal before installation.

For further information please refer to the installation instructions on page 63.



PSH+RR

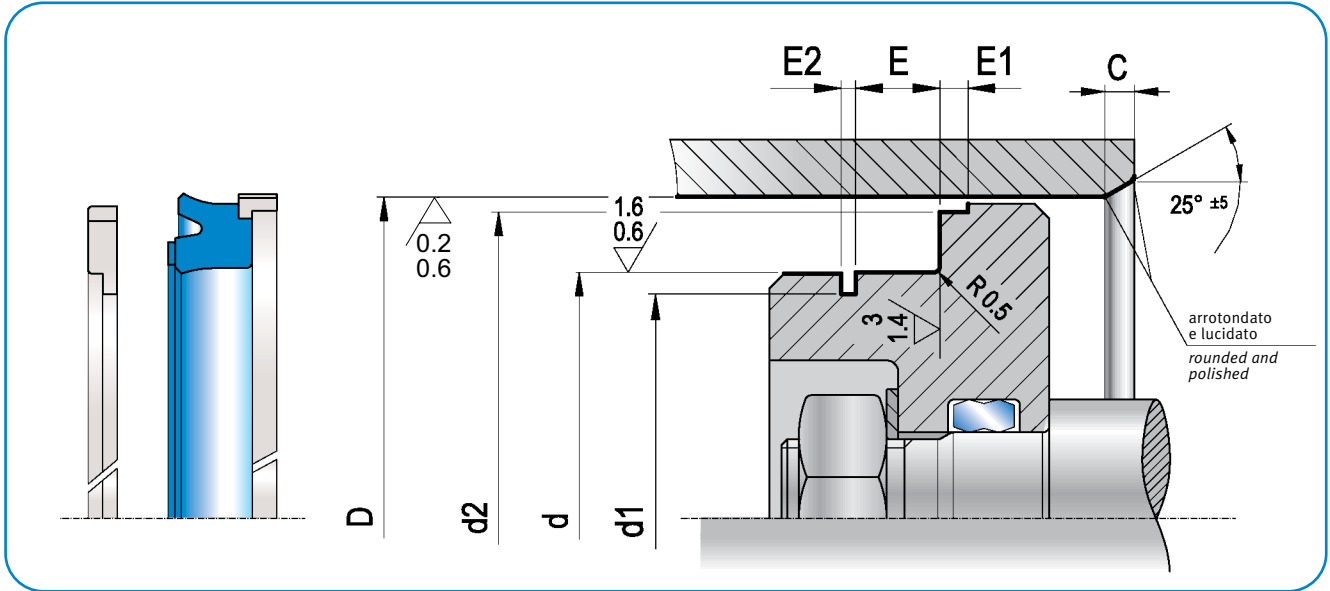
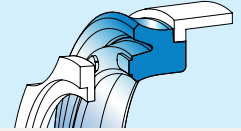

D _{H9}	d _{h9}	E +0,2	E ₂ +0,1 +0,2	d ₂ 0/-0,05	E ₁ ±0,1	C	d ₁ ±0,1	ART / ITEM	ART / ITEM
32,0	20,0	10,0	3,10	28,50	6,35	4,0	15,80	PSH 0320 0200 100 CR	RR 0320 0200 R2
35,0	22,0	10,0	3,10	31,40	6,35	4,0	17,80	PSH 0350 0220 100 CR	RR 0350 0220 R2
40,0	26,0	9,4	3,10	35,40	6,35	4,0	21,60	PSH 0400 0260 094 CR	RR 0400 0260 R2
45,0	30,0	9,5	3,10	40,40	6,35	4,0	25,80	PSH 0450 0300 095 CR	RR 0450 0300 R2
50,0	30,0	14,5	3,35	44,30	6,35	4,0	25,80	PSH 0500 0300 145 CR	RR 0500 0300 R2
50,0	35,0	11,0	3,10	45,35	6,35	4,0	30,60	PSH 0500 0350 110 CR	RR 0500 0350 R2
55,0	40,0	11,0	3,10	50,36	6,35	4,0	35,80	PSH 0550 0400 110 CR	RR 0550 0400 R2
60,0	40,0	14,5	3,35	55,40	6,35	4,0	36,10	PSH1 0600 0400 145 CR	RR 0600 0400 R2
60,0	40,0	14,5	3,35	54,20	6,35	4,0	36,10	PSH 0600 0400 145 CR	RR 0600 0400 R2
60,0	45,0	11,0	3,10	54,20	6,35	4,0	40,60	PSH 0600 0450 110 CR	RR 0600 0450 R2
63,0	45,0	10,5	3,10	58,40	6,35	4,0	40,84	PSH 0630 0450 105 CR	RR 0630 0450 R2
70,0	50,0	14,5	3,35	64,20	6,35	5,0	45,84	PSH 0700 0500 145 CR	RR 0700 0500 R2
75,0	55,0	14,5	3,35	69,20	6,35	5,0	51,10	PSH 0750 0550 145 CR	RR 0750 0550 R2
90,0	70,0	14,5	3,35	84,15	6,35	5,0	66,10	PSH 0900 0700 145 CR	RR 0900 0700 R2
95,0	75,0	14,5	3,35	89,15	6,35	5,0	71,10	PSH 0950 0750 145 CR	RR 0950 0750 R2

Nota: altre dimensioni non a catalogo a richiesta. Consultare il nostro ufficio tecnico.

Remark: please contact our technical dept. for further dimensions not included in the catalogue.

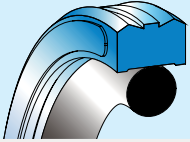

PSO

TENUTA PISTONE TIPO PSO

Descrizione

La guarnizione tipo PSO ha uno speciale profilo con doppie punte sulla parte dinamica e un piano con due piccoli gradini di contenimento sulla parte statica dove alloggia l'o-ring, che energizza la guarnizione e garantisce la perfetta tenuta a basse e alte pressioni. Il peculiare profilo evita pressioni idrodinamiche sulla tenuta e di conseguenza l'effetto blow-by.

Dati tecnici

Pressione: < 250 bar con materiale standard
93 Sh A a 60° C (Co)

Pressione: < 400 bar con materiale alternativo
98 Sh A a 60° C (Do)

Pressione: < 500 bar con materiale alternativo
60 Sh D a 60° C (Eo)

Velocità: < 0.5 m/s

Temperatura: da - 35° C a + 100° C con punte fino a
110° C

Fluidi: fluidi a base minerale
(v. tabella 3 a p. 14)

Materiale

I materiali proposti sono TPU in differenti durezza a seconda delle pressioni di esercizio (Co/Do / Eo).
O-ring in NBR 70 Shore A. (No).
Codice materiale: CN (o in alternativa DN/EN)

Montaggio

- Eliminare spigoli taglienti e bave nella sede dove alloggia la guarnizione
- eseguire lo smusso di invito sulla camicia per facilitare il montaggio del pistone.

Per ulteriori informazioni leggere le istruzioni a p. 63.

Nota: in caso di finitura da lucido di trafilatura si consiglia l'utilizzo di tenuta pistone in PTFE.

PSO TYPE PISTON SEAL

Description

The PSO seal type shows a double profile on the dynamic side and a surface with two small steps on the static side, where the o-ring is housed. The presence of the o-ring, which energizes the seal, ensures a perfect seal performance at low and high pressure. The special double profile avoids any hydro-dynamic pressure on the sealing part and the consequent blow-by effect.

Technical data

Pressure: < 250 bar with standard material 93 Sh A at 60° C (Co)

Pressure: < 400 bar with alternative material 98 Sh A at 60° C (Do)

Pressure: < 500 bar with alternative material 60 Sh D at 60° C (Eo)

Speed: < 0.5 m/s

Temperature: from - 35° C to + 100° C, with peaks at 110° C

Fluids: mineral-based fluids
(see table 3, page 14)

Material

Material proposed are TPUs with different hardness according to the working pressure (Co / Do / Eo).
O-ring in NBR 70 Shore A (No).
Compound reference: CN (or, in alternative, DN / EN).

Assembling

- Remove any cutting edges and flash in the housing of the seal
- ensure a lead-in chamfer in the bore to facilitate the piston installation.

For further information please refer to the installation instructions page 63.

Note: in case of Bright drawn surface machining it is recommended to use PTFE piston seals.



PSO

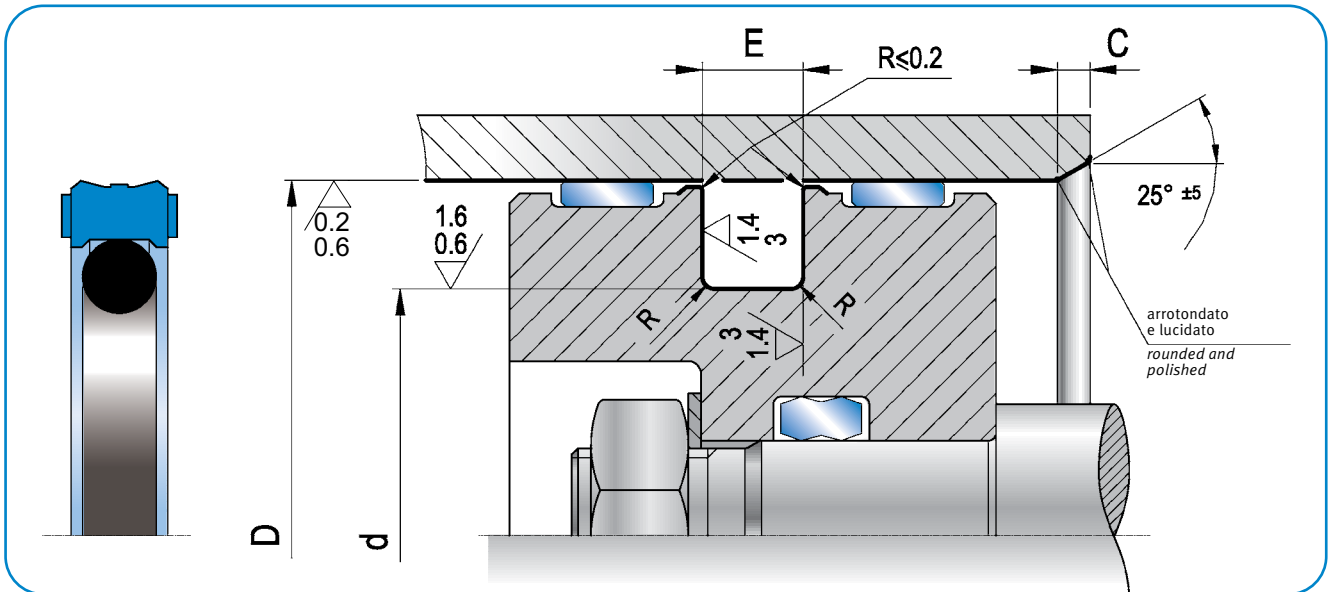
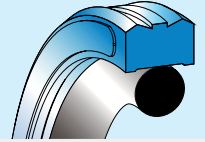

D _{H9}	d _{h9}	E _{+0,2}	C	R	o-ring (no)	ART / ITEM				
12,00	7,10	2,2	2,0	0,2	OR 610	PSO	0120	0071	022	CN
15,00	10,10	2,2	2,0	0,2	OR 012	PSO	0150	0101	022	CN
18,00	10,50	3,2	3,0	0,2	OR 613	PSO	0180	0105	032	CN
* 20,00	12,50	3,2	3,0	0,2	OR 112	PSO	0200	0125	032	CN
22,00	14,50	3,2	3,0	0,2	OR 113	PSO	0220	0145	032	CN
22,50	15,00	3,2	3,0	0,2	OR 113	PSO	0225	0150	032	CN
24,00	16,50	3,2	3,0	0,2	OR 114	PSO	0240	0165	032	CN
* 25,00	14,00	4,2	4,0	0,4	OR 207	PSO	0250	0140	042	CN
* 25,00	17,50	3,2	3,0	0,2	OR 115	PSO	0250	0175	032	CN
28,00	20,50	3,2	3,0	0,4	OR 117	PSO	0280	0205	032	CN
30,00	22,50	3,2	3,0	0,4	OR 118	PSO	0300	0225	032	CN
32,00	21,00	4,2	4,0	0,4	OR 211	PSO	0320	0210	042	CN
* 32,00	24,50	3,2	3,0	0,4	OR 119	PSO	0320	0245	032	CN
35,00	24,00	4,2	4,0	0,4	OR 213	PSO	0350	0240	042	CN
35,00	27,50	3,2	3,0	0,4	OR 121	PSO	0350	0275	032	CN
36,00	25,00	4,2	4,0	0,4	OR 213	PSO	0360	0250	042	CN
36,00	28,50	3,2	3,0	0,4	OR 122	PSO	0360	0285	032	CN
38,00	30,50	3,2	3,0	0,4	OR 123	PSO	0380	0305	032	CN
40,00	24,50	6,3	5,0	0,5	OR 318	PSO	0400	0245	063	CN
* 40,00	29,00	4,2	4,0	0,4	OR 216	PSO	0400	0290	042	CN
42,00	31,00	4,2	4,0	0,5	OR 217	PSO	0420	0310	042	CN
45,00	29,50	6,3	5,0	0,5	OR 320	PSO	0450	0295	063	CN
45,00	34,00	4,2	4,0	0,5	OR 219	PSO	0450	0340	042	CN
48,00	37,00	4,2	4,0	0,5	OR 221	PSO	0480	0370	042	CN
49,00	38,00	4,2	4,0	0,5	OR 222	PSO	0490	0380	042	CN
50,00	34,50	6,3	5,0	0,5	OR 324	PSO	0500	0345	063	CN
* 50,00	39,00	4,2	4,0	0,5	OR 222	PSO	0500	0390	042	CN

* in conformità alle norme ISO/DIN 5597 e ISO 5597/1 – in accordance with ISO/DIN 5597 and ISO 5597/1 norms

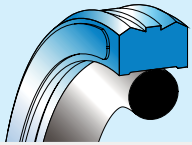

PSO

D _{H9}	d _{h9}	E _{+0,2}	C	R	o-ring (no)	ART / ITEM				
50,00	42,00	4,2	4,0	0,5	OR 223	PSO	0500	0420	042	CN
50,80	39,80	4,2	4,0	0,5	OR 222	PSO	0508	0398	042	CN
52,00	36,50	6,3	5,0	0,5	OR 324	PSO	0520	0365	063	CN
55,00	39,50	6,3	5,0	0,5	OR 325	PSO	0550	0395	063	CN
55,00	44,00	4,2	4,0	0,5	OR 224	PSO	0550	0440	042	CN
57,00	46,00	4,2	4,0	0,5	OR 224	PSO	0570	0460	042	CN
60,00	44,50	6,3	5,0	0,5	OR 327	PSO	0600	0445	063	CN
60,00	49,00	4,2	4,0	0,5	OR 225	PSO	0600	0490	042	CN
* 63,00	47,50	6,3	5,0	0,5	OR 328	PSO	0630	0475	063	CN
* 63,00	52,00	4,2	4,0	0,5	OR 226	PSO	0630	0520	042	CN
63,50	52,50	4,2	4,0	0,5	OR 226	PSO	0635	0525	042	CN
65,00	49,50	6,3	5,0	0,5	OR 328	PSO	0650	0495	063	CN
65,00	54,00	4,2	4,0	0,5	OR 227	PSO	0650	0540	042	CN
70,00	54,50	6,3	5,0	0,5	OR 330	PSO	0700	0545	063	CN
70,00	59,00	4,2	4,0	0,5	OR 228	PSO	0700	0590	042	CN
72,00	61,00	4,2	4,0	0,5	OR 229	PSO	0720	0610	042	CN
75,00	59,50	6,3	5,0	0,5	OR 331	PSO	0750	0595	063	CN
75,00	64,00	4,2	4,0	0,5	OR 230	PSO	0750	0640	042	CN
* 80,00	64,50	6,3	5,0	0,5	OR 333	PSO	0800	0645	063	CN
* 80,00	69,00	4,2	4,0	0,5	OR 842	PSO	0800	0690	042	CN
85,00	69,50	6,3	5,0	0,5	OR 335	PSO	0850	0695	063	CN
88,90	73,40	6,3	5,0	0,5	OR 336	PSO	0889	0734	063	CN
90,00	74,50	6,3	5,0	0,5	OR 336	PSO	0900	0745	063	CN
95,00	79,50	6,3	5,0	0,5	OR 338	PSO	0950	0795	063	CN
* 100,00	84,50	6,3	5,0	0,5	OR 339	PSO	1000	0845	063	CN
105,00	89,50	6,3	5,0	0,5	OR 341	PSO	1050	0895	063	CN
110,00	94,50	6,3	5,0	0,5	OR 343	PSO	1100	0945	063	CN
115,00	94,00	8,1	6,0	0,5	OR 94X7	PSO	1150	0940	081	CN
115,00	99,50	6,3	5,0	0,5	OR 344	PSO	1150	0995	063	CN
118,00	102,50	6,3	5,0	0,5	OR 345	PSO	1180	1025	063	CN
120,00	104,50	6,3	5,0	0,5	OR 346	PSO	1200	1045	063	CN
* 125,00	104,00	8,1	6,0	0,5	OR 100X7	PSO	1250	1040	081	CN
* 125,00	109,50	6,3	5,0	0,5	OR 347	PSO	1250	1095	063	CN
130,00	109,00	8,1	6,0	0,6	OR 106X7	PSO	1300	1090	081	CN
130,00	114,50	6,3	5,0	0,6	OR 349	PSO	1300	1145	063	CN
135,00	114,00	8,1	6,0	0,6	OR 425	PSO	1350	1140	081	CN
135,00	119,50	6,3	5,0	0,6	OR 350	PSO	1350	1195	063	CN
140,00	119,00	8,1	6,0	0,6	OR 426	PSO	1400	1190	081	CN
145,00	124,00	8,1	6,0	0,6	OR 428	PSO	1450	1240	081	CN



PSO

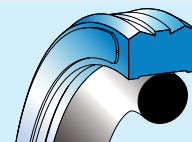

	D _{H9}	d _{h9}	E _{+0,2}	C	R	o-ring (no)	ART / ITEM				
*	150,00	129,00	8,1	6,0	0,6	OR 430	PSO	1500	1290	081	CN
	160,00	139,00	8,1	6,0	0,6	OR 433	PSO	1600	1390	081	CN
	170,00	149,00	8,1	6,0	0,6	OR 436	PSO	1700	1490	081	CN
	177,80	156,80	8,1	6,0	0,6	OR 437	PSO	1778	1568	081	CN
	180,00	159,00	8,1	6,0	0,6	OR 438	PSO	1800	1590	081	CN
	185,00	164,00	8,1	6,0	0,6	OR 874	PSO	1850	1640	081	CN
*	190,00	169,00	8,1	6,0	0,6	OR 439	PSO	1900	1690	081	CN
	200,00	179,00	8,1	6,0	0,6	OR 441	PSO	2000	1790	081	CN
	210,00	189,00	8,1	6,0	0,6	OR 443	PSO	2100	1890	081	CN
	220,00	199,00	8,1	6,0	0,6	OR 444	PSO	2200	1990	081	CN
	230,00	209,00	8,1	6,0	0,6	OR 445	PSO	2300	2090	081	CN
	240,00	219,00	8,1	6,0	0,6	OR 446	PSO	2400	2190	081	CN
*	250,00	229,00	8,1	6,0	0,6	OR 447	PSO	2500	2290	081	CN

* in conformità alle norme ISO/DIN 5597 e ISO 5597/1 – in accordance with ISO/DIN 5597 and ISO 5597/1 norms

Materiali alternativi: DN (98 Sh A); EN (55 Sh D) – Alternative compounds: DN (98 Sh A); EN (55 Sh D)

Nota: altre dimensioni non a catalogo a richiesta. Consultare il nostro ufficio tecnico.

Remark: please contact our technical dept. for further dimensions not included in the catalogue.

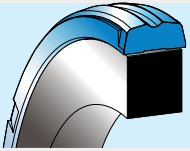

PSQ

TENUTA PISTONE TIPO PSQ

Descrizione

La guarnizione PSQ ha uno speciale profilo con doppie punte centrali nella parte dinamica e un piano di due piccoli gradini nella parte statica dove alloggia il q-ring, che energizza la guarnizione e garantisce la perfetta tenuta a bassa e alta pressione. La geometria del profilo evita pressioni idrodinamiche sulla tenuta e di conseguenza l'effetto blow-by.

Dati tecnici

Pressione: < 250 Bar con materiale tipo Co a 93 Shore A a temperatura di 60° C.
< 400 Bar con materiale tipo Do a 98 Shore A a temperatura di 60° C.

Velocità: < 0,8 m/s

Temperatura: da - 35° C a + 100 ° C con punte fino a 110° C.

Fluidi: oli a base minerale (v. tabella 3 a p. 14)

Materiale

I materiali proposti sono TPU di diverse durezza a seconda delle pressioni di esercizio.
Codice materiale: CN (93 Shore A con Q-Ring) o, in alternativa, DN (98 Shore A con Q-Ring)

Montaggio

- Eliminare gli spigoli taglienti e le bave nella sede dove alloggia la guarnizione
- eseguire lo smusso d'invito sulla camicia per facilitare il montaggio del pistone.

Per ulteriori informazioni leggere le istruzioni a p. 63.

Nota: in caso di finitura da lucido di trafilatura si consiglia l'utilizzo di tenuta pistone in PTFE.

PSQ TYPE PISTON SEAL

Description

The PSQ seal has a double point profile in the in the dynamic part, and two small steps in the static part where the Q-ring is housed. The Q-ring energizes the seal and provides a perfect sealing performance at low and high pressure. The shape of the central double profile prevents hydrodynamic pressures on the seal and the resulting blow-out effect.

Technical data

Pressure: < 250 Bar with a Co-type material at 93 Shore A, at a temperature of 60°C.
< 400 Bar a Do-type material, at 98 Shore A, at a temperature of 60° C.

Speed: < 0.8 m/s

Temperature: from - 35° C to + 100 ° C with peaks up to 110° C.

Fluids: mineral oils (see table 3, page 14)

Material

Material proposed are TPUs with different hardness according to the working pressure.
Compound reference: CN (93 Shore A with Q-ring) or, alternatively, DN (98 Shore A with Q-ring)

Assembling

- Cutting edges or flash must be removed in the housing of the seal
- ensure a lead-in chamfer in the bore to facilitate the piston installation.

For further information please refer to the assembly instructions on page 63.

Note: in case of bright drawn surface machining it is recommended to use PTFE piston seals.



PSQ

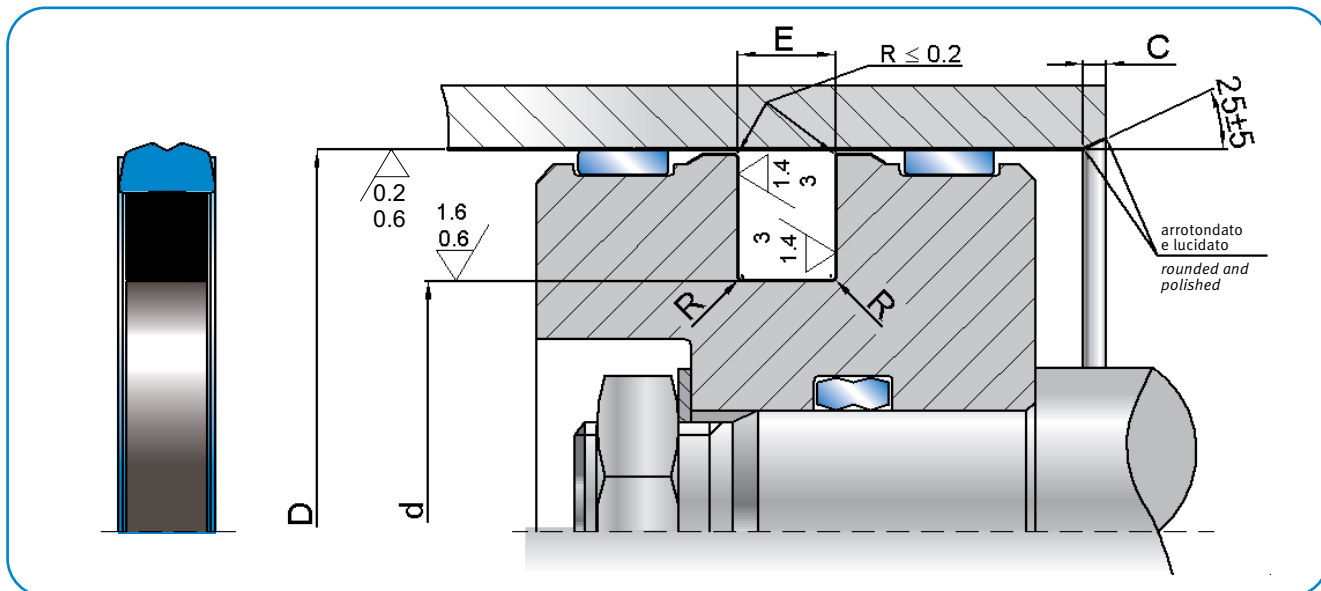
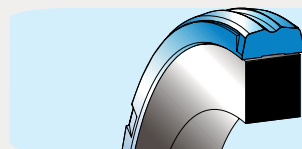

Oleodinamica
Hydraulic

D _{H9}	d _{h9}	E _{+0.2}	C	R	ART / ITEM	
40,0	24,5	6,3	5,0	0,4	PSQ 0400 0245 063 CN	
*	40,0	29,0	4,2	4,0	0,3	PSQ 0400 0290 042 CN
45,0	29,5	6,3	4,0	0,3	PSQ 0450 0295 063 CN	
45,0	34,0	4,2	4,0	0,3	PSQ 0450 0340 042 CN	
*	50,0	34,5	6,3	5,0	0,4	PSQ 0500 0345 063 CN
*	50,0	39,0	4,2	4,0	0,3	PSQ 0500 0390 042 CN
55,0	39,5	6,3	5,0	0,4	PSQ 0550 0395 063 CN	
55,0	44,0	4,2	5,0	0,4	PSQ 0550 0440 042 CN	
60,0	44,5	6,3	5,0	0,4	PSQ 0600 0445 063 CN	
60,0	49,0	4,2	4,0	0,3	PSQ 0600 0490 042 CN	
*	63,0	47,5	6,3	5,0	0,4	PSQ 0630 0475 063 CN
*	63,0	52,0	4,2	5,0	0,3	PSQ 0630 0520 042 CN
65,0	49,5	6,3	4,0	0,4	PSQ 0650 0495 063 CN	
70,0	54,5	6,3	5,0	0,4	PSQ 0700 0545 063 CN	
70,0	59,0	4,2	4,0	0,3	PSQ 0700 0590 042 CN	
75,0	59,5	6,3	5,0	0,4	PSQ 0750 0595 063 CN	
75,0	64,0	4,2	5,0	0,4	PSQ 0750 0640 042 CN	
80,0	59,0	8,1	6,0	0,4	PSQ 0800 0590 081 CN	
*	80,0	64,5	6,3	5,0	0,4	PSQ 0800 0645 063 CN
85,0	69,5	6,3	5,0	0,4	PSQ 0850 0695 063 CN	
90,0	69,0	8,1	6,0	0,4	PSQ 0900 0690 081 CN	
90,0	74,5	6,3	5,0	0,4	PSQ 0900 0745 063 CN	
95,0	74,0	8,1	5,0	0,4	PSQ 0950 0740 081 CN	
95,0	79,5	6,3	5,0	0,4	PSQ 0950 0795 063 CN	

D _{H9}	d _{h9}	E _{+0.2}	C	R	ART / ITEM	
100,0	79,0	8,1	6,0	0,4	PSQ 1000 0790 081 CN	
*	100,0	84,5	6,3	5,0	0,4	PSQ 1000 0845 063 CN
105,0	89,5	6,3	5,0	0,4	PSQ 1050 0895 063 CN	
110,0	89,0	8,1	6,0	0,4	PSQ 1100 0890 081 CN	
110,0	94,5	6,3	5,0	0,4	PSQ 1100 0945 063 CN	
115,0	94,0	8,1	6,0	0,4	PSQ 1150 0940 081 CN	
115,0	99,5	6,3	6,0	0,4	PSQ 1150 0995 063 CN	
120,0	99,0	8,1	6,0	0,4	PSQ 1200 0990 081 CN	
*	125,0	104,0	8,1	6,0	0,4	PSQ 1250 1040 081 CN
*	125,0	109,5	6,3	5,0	0,4	PSQ 1250 1095 063 CN
130,0	109,0	8,1	6,0	0,4	PSQ 1300 1090 081 CN	
135,0	114,0	8,1	6,0	0,4	PSQ 1350 1140 081 CN	
140,0	119,0	8,1	6,0	0,4	PSQ 1400 1190 081 CN	
145,0	124,0	8,1	6,0	0,4	PSQ 1450 1240 081 CN	
150,0	129,0	8,1	6,0	0,4	PSQ 1500 1290 081 CN	
155,0	134,0	8,1	6,0	0,4	PSQ 1550 1340 081 CN	
165,0	144,0	8,1	6,0	0,4	PSQ 1650 1440 081 CN	
175,0	149,0	8,1	6,0	0,4	PSQ 1750 1490 081 CN	
180,0	159,0	8,1	6,0	0,4	PSQ 1800 1590 081 CN	
190,0	169,0	8,1	6,0	0,4	PSQ 1900 1690 081 CN	

* ISO 7425

Nota: altre dimensioni non a catalogo a richiesta. Consultare il nostro ufficio tecnico.

Remark: please contact our technical dept. for further dimensions not included in the catalogue.

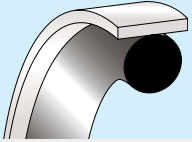

PSN

TENUTA PISTONE TIPO PSN

Descrizione

La tenuta pistone tipo PSN è stata studiata per impieghi oleodinamici e pneumatici. Grazie alla sua elasticità è montabile anche su pistone di tipo monoblocco. La sua caratteristica principale è l'eccezionale scorrevolezza che consente l'utilizzo anche con fluidi a basso potere lubrificante come aria e acqua. Innumerevoli test hanno dato esiti positivi sull'assenza di estrusione del profilo anche con passaggio della tenuta sui fori di drenaggio.

Dati Tecnici

Pressione: < 250 bar
 Velocità: < 4 m/s
 Temperatura: - 30° C a + 120° C,
 Fluidi: oli a base minerale
 (v. tabella 3 a p. 14)

Materiale

Il materiale utilizzato per l'elemento di tenuta è un tecnopolimero ad alta elasticità, mentre per l'elemento energizzante si utilizza un o-ring in NBR 70 Shore A. In alternativa, per la tenuta è utilizzabile PTFE rinforzato bronzo e un o-ring in materiali quali HNBR o FKM per l'elemento energizzante.

Montaggio

Il montaggio avviene in sede anulare in modo elastico.
 Eliminare le bave di lavorazione meccanica.
 Per ulteriori informazioni leggere le istruzioni a p. 63.

PSN TYPE PISTON SEAL

Description

The PSN type piston seal has been designed for both hydraulic and pneumatic applications. Due to its elasticity can also be assembled on monoblock piston type. Its main characteristic is an exceptional smoothness that allows to use this seal even with low lubricity fluids such as air and water. Many tests have given positive results as regards the absence of extrusion of the profile even with the passage of the seal on the drainage holes of the system.

Technical data

Pressure: < 250 bar
 Speed: < 4 m/s
 Temperature: from - 30° C up to + 120° C
 Fluids: mineral oils
 (see table 3, page 14)

Material

The sealing element's material is a technopolymer with high elasticity, whereas, for the energizing element, it is proposed O-ring in NBR 70 Shore A. Alternative material is bronze filled PTFE for the sealing element and, for the energizing element, O-ring in HNBR or FKM.

Assembling

Elastic installation in annular groove. Remove any machining burrs and lubricate the seal before installation. For further information please refer to the installation instructions on page 63.



PSN

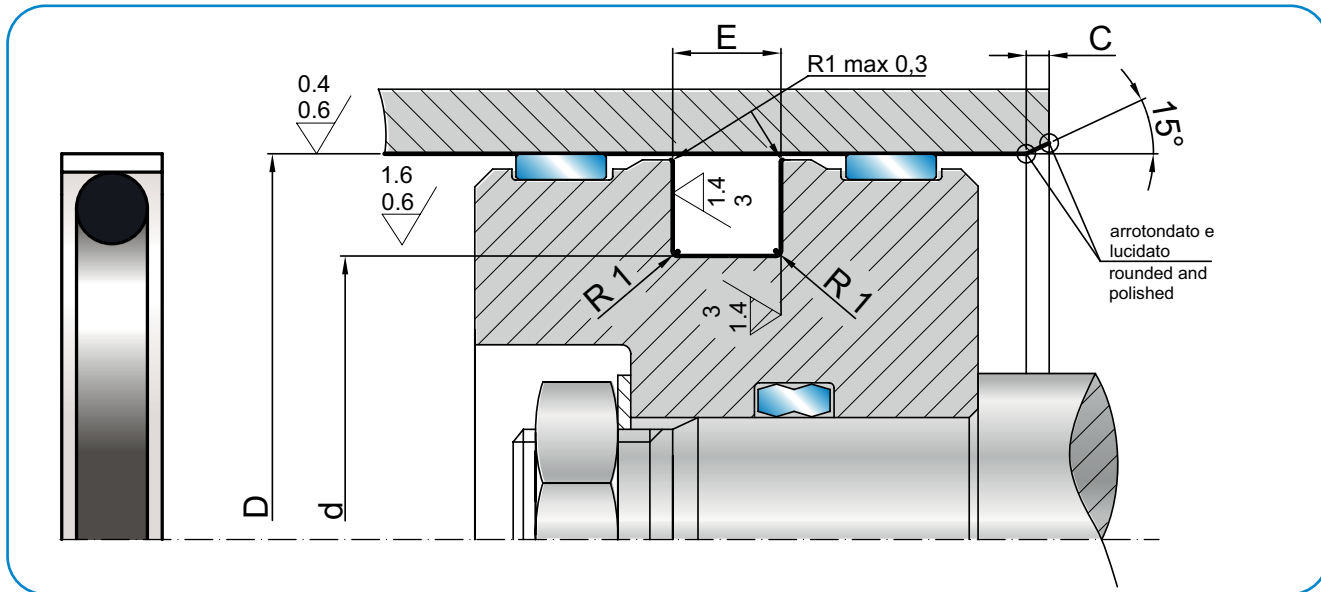
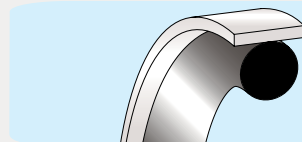

Oleodinamica
Hydraulic

D _{H9}	d _{h9}	E _{+0,2}	O-Ring	C	ART / ITEM
20,00	13,80	3,0	615	5,0	PSN 0200 0138 030 RN
22,00	15,80	3,0	616	5,0	PSN 0220 0158 030 RN
25,00	18,80	3,0	617	5,0	PSN 0250 0188 030 RN
28,00	20,00	4,0	210	5,0	PSN 0280 0200 040 RN
30,00	22,00	4,0	211	5,0	PSN 0300 0220 040 RN
32,00	24,00	4,0	213	5,0	PSN 0320 0240 040 RN
35,00	27,00	4,0	215	5,0	PSN 0350 0270 040 RN
36,00	28,00	4,0	215	5,0	PSN 0360 0280 040 RN
38,00	30,00	4,0	216	5,0	PSN 0380 0300 040 RN
40,00	32,00	4,0	218	5,0	PSN 0400 0320 040 RN
42,00	34,00	4,0	218	5,0	PSN 0420 0340 040 RN
45,00	37,00	4,0	221	5,0	PSN 0450 0370 040 RN
48,00	40,00	4,0	222	5,0	PSN 0480 0400 040 RN
50,00	38,30	6,0	325	5,0	PSN 0500 0383 060 RN
55,00	43,50	6,0	326	5,0	PSN 0550 0435 060 RN
56,00	44,30	6,0	327	5,0	PSN 0560 0443 060 RN
60,00	48,30	6,0	328	5,0	PSN 060 0483 060 RN
63,00	51,30	6,0	329	5,0	PSN 0630 0513 060 RN

D _{H9}	d _{h9}	E _{+0,2}	O-Ring	C	ART / ITEM
65,00	53,30	6,0	329	5,0	PSN 0650 0533 060 RN
70,00	58,40	6,0	331	5,0	PSN 0700 0584 060 RN
75,00	62,90	6,0	332	5,0	PSN 0750 0629 060 RN
80,00	68,00	6,0	334	5,0	PSN 0800 0680 060 RN
85,00	72,90	6,0	336	5,0	PSN 0850 0729 050 RN
90,00	78,00	6,0	337	5,0	PSN 0900 0780 060 RN
95,00	82,90	6,0	339	5,0	PSN 0950 0829 060 RN
100,00	88,00	6,0	340	5,0	PSN 1000 0880 060 RN
110,00	97,90	6,0	343	7,0	PSN 1100 0979 060 RN
120,00	107,90	6,0	346	7,0	PSN 1200 1079 060 RN
125,00	112,50	6,0	348	7,0	PSN 1250 1125 060 RN
130,00	117,50	6,0	349	7,0	PSN 1300 1175 060 RN
140,00	124,50	8,0	428	7,0	PSN 1400 1245 080 RN
160,00	144,20	8,0	434	7,0	PSN 1600 1442 080 RN
180,00	163,70	8,0	874	7,0	PSN 1800 1637 080 RN
200,00	183,70	8,0	880	7,0	PSN 2000 1837 080 RN
250,00	233,70	8,0	447	10,0	PSN 2500 2337 080 RN

Nota: altre dimensioni non a catalogo a richiesta. Consultare il nostro ufficio tecnico.

Remark: please contact our technical dept. for further dimensions not included in the catalogue.

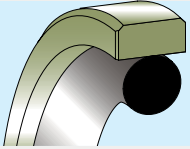

TPD

TENUTA PISTONE TIPO TPD

Descrizione

La tenuta pistone tipo TPD è composta da un anello sagomato in PTFE caricato bronzo a basso coefficiente di attrito, che funge da tenuta dinamica, e di un anello o-ring che effettua la tenuta statica e contemporaneamente svolge un effetto energizzante.

Dati Tecnici

Pressione: < 600 bar

Velocità: < 15 m/s

Temperatura: per il tipo standard con o-ring in nitrile da - 30° C a + 100° C, con punte per periodi brevi fino a 120° C.
Per range di temperature differenti occorre sostituire l'o-ring in NBR con materiali più idonei.

Materiale

Per il tipo standard PTFE isostatico caricato bronzo e o-ring in nitrile.

Codice materiale: TN

Per applicazioni fino a <250 bar è possibile utilizzare materiale alternativo PTFE estruso caricato bronzo

Codice materiale : TM2

Montaggio

Le guarnizioni in PTFE necessitano di precauzioni estremamente rigorose, maggiori che per tutte le altre tipologie di tenuta. È fondamentale eliminare gli spigoli vivi e le bave nelle sedi. Il montaggio delle guarnizioni per stelo segue normalmente questa sequenza:

- installare l'o-ring nella sede
- spingere dilatando l'anello in PTFE con l'ausilio di un mandrino e una bussola a espansione
- calibrare con una bussola opportunamente dimensionata (p.64).

TPD TYPE PISTON SEAL

Description

The TPD piston seal is composed of two rings. The dynamic seal is a shaped in bronze filled PTFE with very low friction coefficient. The static seal is an O-Ring also working as energizer.

Technical data

Pressure: < 600 bar

Speed: < 15 m/s

Temperature: from - 30° C up to + 100° C for the standard type with nitrile OR. Short peaks till 120° C. For a different temperature range, the O-Ring in NBR should be replaced by a more suitable material.

Material

Bronze-filled PTFE for the standard type, and NBR for the O-Ring.

Compound reference: TN

For applications until <250 bar is possible to use alternative material Bronze-filled extruded PTFE

Compound reference: TM2

Assembling

PTFE seals require careful assembling operations in comparison to other types of seals It is necessary to remove flashes and/or cutting edges in the grooves. The rod seal is usually assembled in the following Sequence:

- fit the O-Ring into the groove
- twist the PTFE ring using a mandrel and a expansion bush
- calibrate with a bush with right dimension (Pag.64).



TPD

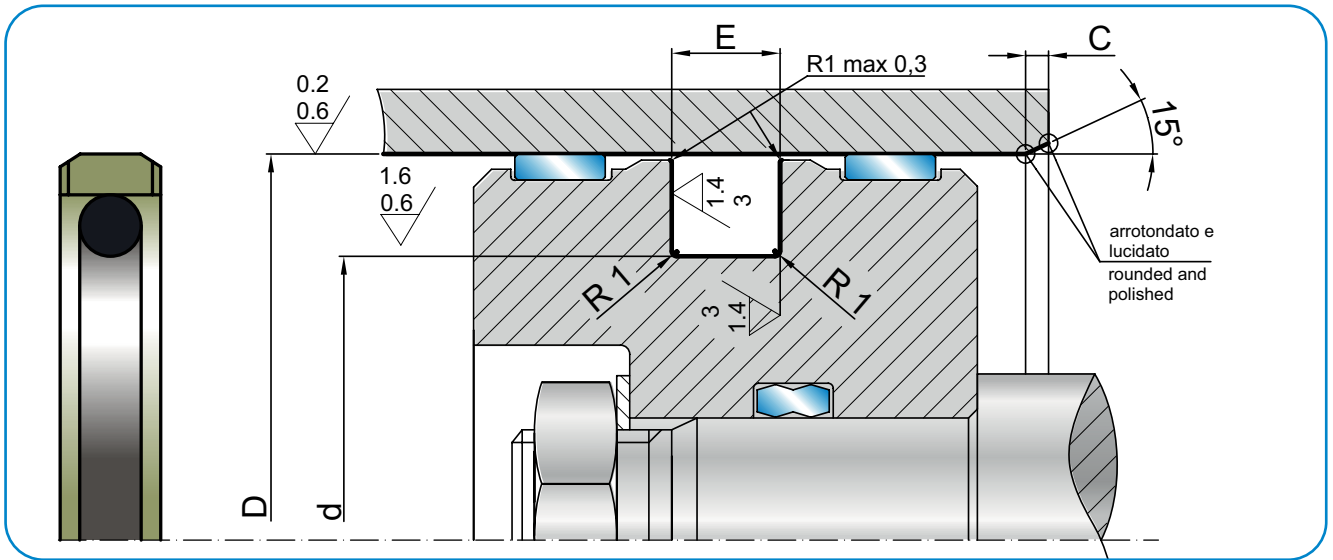
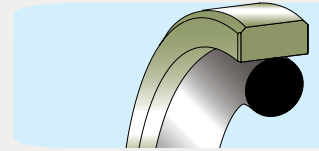

D _{H9}	d _{h9}	E _{+0,2}	O-Ring	C	ART / ITEM
8,0	3,1	2,2	006	5,0	TPD 0080 0031 022 TN
10,0	5,1	2,2	008	5,0	TPD 0100 0051 022 TN
12,0	7,1	2,2	010	5,0	TPD 0120 0071 022 TN
15,0	7,5	3,2	108	5,0	TPD 0150 0075 032 TN
16,0	8,5	3,2	109	5,0	TPD 0160 0085 032 TN
18,0	10,5	3,2	110	5,0	TPD 0180 0105 032 TN
20,0	12,5	3,2	111	5,0	TPD 0200 0125 032 TN
20,0	15,1	2,2	015	5,0	TPD 0200 0151 022 TN
22,0	14,5	3,2	113	5,0	TPD 0220 0145 032 TN
24,0	16,5	3,2	114	5,0	TPD 0240 0165 032 TN
25,0	20,1	2,2	018	5,0	TPD 0250 0201 022 TN
25,0	17,5	3,2	115	5,0	TPD 0250 0175 032 TN
28,0	20,5	3,2	116	5,0	TPD 0280 0205 032 TN
30,0	22,5	3,2	118	5,0	TPD 0300 0225 032 TN
32,0	24,5	3,2	119	5,0	TPD 0320 0245 032 TN
35,0	27,5	3,2	121	5,0	TPD 0350 0275 032 TN
39,0	31,5	3,2	124	5,0	TPD 0390 0315 032 TN
40,0	29,0	4,2	216	5,0	TPD 0400 0290 042 TN
42,0	31,0	4,2	217	5,0	TPD 0420 0310 042 TN
45,0	34,0	4,2	219	5,0	TPD 0450 0340 042 TN
48,0	37,0	4,2	221	5,0	TPD 0480 0370 042 TN
50,0	39,0	4,2	222	5,0	TPD 0500 0390 042 TN
52,0	41,0	4,2	223	5,0	TPD 0520 0410 042 TN
55,0	44,0	4,2	224	5,0	TPD 0550 0440 042 TN
60,0	49,0	4,2	225	5,0	TPD 0600 0490 042 TN
63,0	52,0	4,2	226	5,0	TPD 0630 0520 042 TN
65,0	54,0	4,2	227	5,0	TPD 0650 0540 042 TN
70,0	59,0	4,2	228	5,0	TPD 0700 0590 042 TN
75,0	64,0	4,2	230	5,0	TPD 0750 0640 042 TN
80,0	64,5	6,3	333	5,0	TPD 0800 0645 063 TN

D _{H9}	d _{h9}	E _{+0,2}	O-Ring	C	ART / ITEM
85,0	69,5	6,3	335	5,0	TPD 0850 0695 063 TN
90,0	74,5	6,3	336	5,0	TPD 0900 0745 063 TN
100,0	84,5	6,3	339	5,0	TPD 1000 0845 063 TN
105,0	89,5	6,3	341	7,0	TPD 1050 0895 063 TN
110,0	94,5	6,3	343	7,0	TPD 1100 0945 063 TN
115,0	94,0	8,1		7,0	TPD 1100 0940 081 TN
115,0	99,5	6,3	344	7,0	TPD 1150 0995 063 TN
120,0	104,5	6,3	346	7,0	TPD 1200 1045 063 TN
125,0	104,0	8,1		7,0	TPD 1250 1040 081 TN
125,0	109,5	6,3	347	7,0	TPD 1250 1095 063 TN
130,0	114,5	6,3	349	7,0	TPD 1300 1145 063 TN
135,0	114,0	8,1	425	7,0	TPD 1350 1140 081 TN
140,0	119,0	8,1	426	7,0	TPD 1400 1190 081 TN
145,0	124,0	8,1	428	7,0	TPD 1450 1240 081 TN
150,0	129,0	8,1	429	7,0	TPD 1500 1290 081 TN
160,0	139,0	8,1	433	7,0	TPD 1600 1390 081 TN
170,0	149,0	8,1	436	7,0	TPD 1700 1490 081 TN
180,0	159,0	8,1	438	7,0	TPD 1800 1590 081 TN
190,0	169,0	8,1	439	7,0	TPD 1900 1690 081 TN
200,0	179,0	8,1	441	7,0	TPD 2000 1790 081 TN
210,0	189,0	8,1	442	10,0	TPD 2100 1890 081 TN
220,0	199,0	8,1	444	10,0	TPD 2200 1990 081 TN
230,0	209,0	8,1	445	10,0	TPD 2300 2090 081 TN
240,0	219,0	8,1	446	10,0	TPD 2400 2190 081 TN
250,0	229,0	8,1	447	10,0	TPD 2500 2290 081 TN
260,0	239,0	8,1	447	10,0	TPD 2600 2390 081 TN
270,0	249,0	8,1	448	10,0	TPD 2700 2490 081 TN
280,0	259,0	8,1	449	10,0	TPD 2800 2590 081 TN
290,0	269,0	8,1	450	10,0	TPD 2900 2690 081 TN
300,0	279,0	8,1	451	10,0	TPD 3000 2790 081 TN

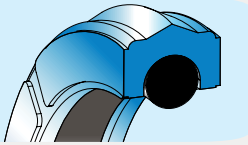

PSI

TENUTA PISTONE TIPO PSI

Descrizione

La guarnizione tipo PSI ha un profilo simmetrico che permette la tenuta a doppio effetto. Il profilo ha una cava nella parte interna dove alloggia un o-ring, che energizza la guarnizione, ne garantisce la perfetta tenuta sia a basse che ad alte pressioni grazie anche alla presenza di tacche assiali. Le tacche radiali consentono un effetto anti-incollaggio e di sfiato.

Dati tecnici

Pressione: < 350 bar
 Velocità: < 1 m/s
 Temperatura: da - 35° C a + 100° C con punte fino a 110° C
 Fluidi: fluidi a base minerale

Materiale

Il materiale proposto è Co: TPU durezza 94Shore A. L'o-ring in NBR 70 Shore A. (No).
 Codice materiale: CN.

Montaggio

E' necessario eliminare spigoli taglienti e bave nella sede dove alloggia la guarnizione. Eseguire smusso di invito sulla camicia per facilitare il montaggio del pistone.

Nota: non utilizzare in caso la finitura della camicia sia realizzata da lucido di trafilatura.

Fig. 35 - Pic.35:

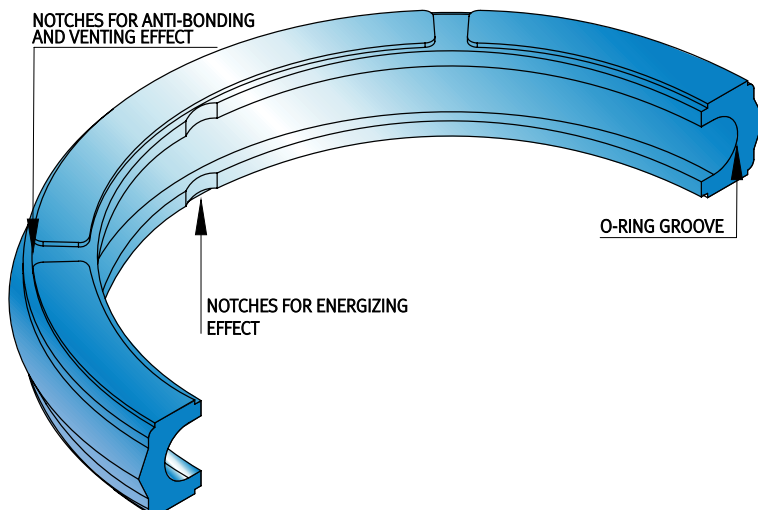

PSI TYPE PISTON SEAL

Description

The PSI seal type shows a double effect profile on the dynamic face due to the symmetrical shape. The internal groove that houses the O-Ring also has axial notches to help energize the seal and ensures perfect sealing performance at both low and high pressure. Radial notches on the side ensure an anti-bonding and venting effect.

Technical data

Pressure: < 350 bar
 Speed: < 1 m/s
 Temperature: from - 35° C to + 100° C, with peaks at 110° C
 Fluids: mineral-based fluids

Material

Material proposed is Co: TPU 94 Shore A hardness. O-ring in NBR 70 Shore A (No).
 Compound reference: CN.

Assembling

To prevent any damage to the seal during assembly, remove all swarf and sharp edges within the housing. Ensure a lead-in chamfer in the bore to facilitate the piston installation.

Note: do not use in case of Bright drawn surface machining on bore.

gioco di accoppiamento / coupling clearance	
PRESSIONE / PRESSURE bar	G mm
50	0,50
100	0,40
150	0,30
200	0,15
300	0,10

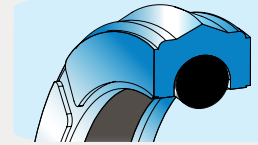

PSI

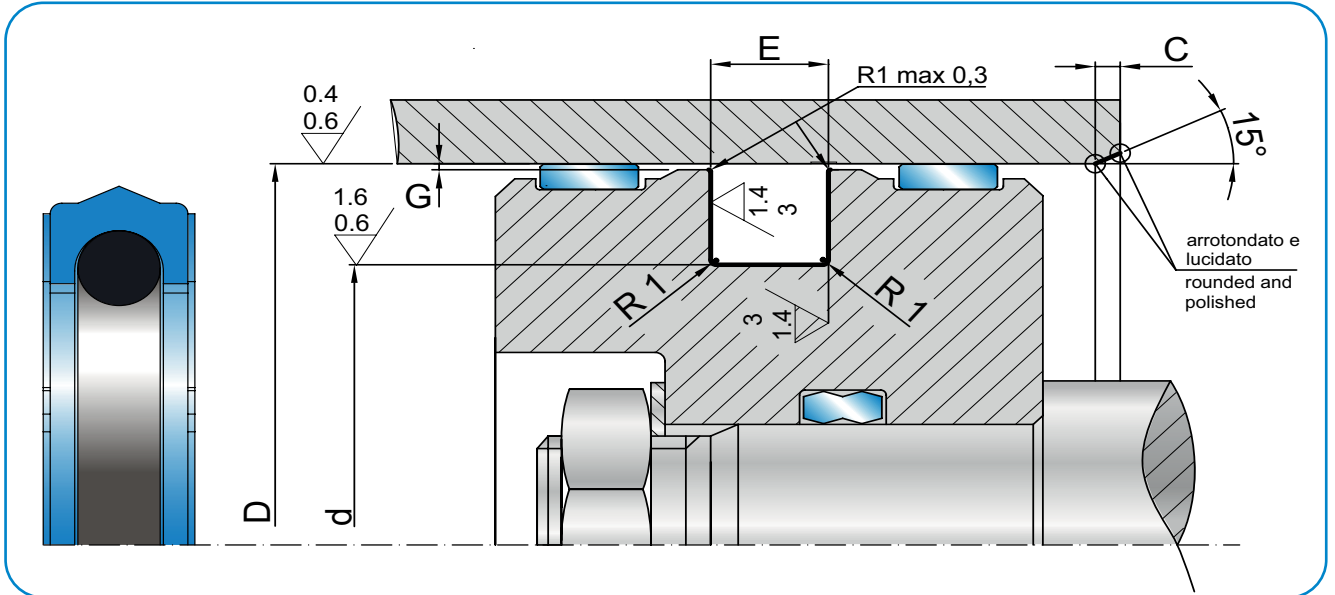

Oleodinamica
Hydraulic

D _{H8}		d _{h9}		E _{+0,2}		ART / ITEM				
inch	mm	inch	mm	inch	mm					
1,250	31,75	1,008	25,60	0,187	4,75	PSI	1250	1008	0187	CN
1,250	31,75	1,062	27,00	0,150	3,81	PSI	1250	1062	0150	CN
1,500	38,10	1,258	31,95	0,187	4,75	PSI	1500	1258	0187	CN
1,750	44,45	1,508	38,30	0,187	4,75	PSI	1750	1508	0187	CN
1,750	44,45	1,562	39,67	0,150	3,81	PSI	1750	1562	0150	CN
2,000	50,80	1,625	41,27	0,281	7,13	PSI	2000	1625	0281	CN
2,000	50,80	1,625	41,27	0,424	10,76	PSI	2000	1625	0424	CN
2,250	57,15	1,875	47,62	0,281	7,13	PSI	2250	1875	0281	CN
2,500	63,50	2,125	53,97	0,281	7,13	PSI	2500	2125	0281	CN
2,500	63,50	2,125	53,97	0,424	10,76	PSI	2500	2125	0424	CN
3,000	76,20	2,625	66,67	0,281	7,13	PSI	3000	2625	0281	CN
3,000	76,20	2,625	66,67	0,424	10,76	PSI	3000	2625	0424	CN
3,500	88,90	3,125	79,37	0,281	7,13	PSI	3500	3125	0281	CN
3,500	88,90	3,125	79,37	0,424	10,76	PSI	3500	3125	0424	CN
4,000	101,60	3,625	92,07	0,281	7,13	PSI	4000	3625	0281	CN
4,000	101,60	3,625	92,07	0,424	10,76	PSI	4000	3625	0424	CN
4,250	107,95	3,875	98,42	0,424	10,76	PSI	4250	3875	0424	CN
4,500	114,30	4,125	104,77	0,281	7,13	PSI	4500	4125	0281	CN
4,500	114,30	4,125	104,77	0,424	10,76	PSI	4500	4125	0424	CN
5,000	127,00	4,625	117,47	0,281	7,13	PSI	5000	4,625	0281	CN
5,500	139,70	5,125	130,17	0,281	7,13	PSI	5500	5125	0281	CN
6,000	152,40	5,625	142,875	0,281	7,13	PSI	6000	5625	0281	CN

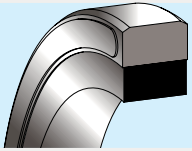

PSZ

TENUTA PISTONE TIPO PSZ

Descrizione

La tenuta PSZ a doppio effetto, per movimenti solo dinamici, è il risultato della combinazione tra un pattino in materiale plastico tagliato a gradino e un anello in materiale elastomerico (NBR) di sezione rettangolare con funzione energizzante.

L'alta resistenza del materiale plastico permette alla tenuta di resistere a pressioni elevate e a giochi radiali (pistone/camicia) di gran lunga superiori alle attuali tenute. Le lavorazioni meccaniche del pistone risultano così semplificate e facilitate. Utilizzata in escavatori, sollevatori, gru e carrelli elevatori.

Limiti d'impiego

Pressione: < 800 bar (con picchi fino a 1000 bar)
 Velocità: < 1 m/s
 Temperatura: da - 30 °C a +110°C
 Fluidi: fluidi e oli a base minerale.
 (v. tabella 3 a p.14)

Materiale

Anello elastomerico in NBR 75 Shore A.
 Pattino in materiale PA66 modificato.

Montaggio

Il montaggio è semplificato grazie al pattino tagliato a gradino.
 Si monta in cava chiusa dopo aver montato l'elemento energizzante in NBR e si consiglia di ingrassare prima di inserire il pistone nel cilindro.

Nota: non utilizzare in applicazioni statiche.

Fig. 36 - Pic.36:

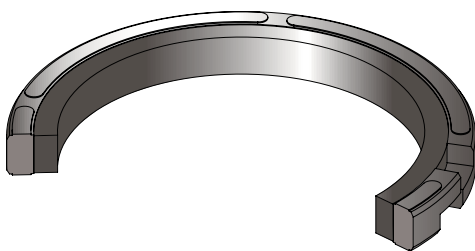

PSZ TYPE PISTON SEAL

Description

The double effect PSZ seal only for dynamic movement, is the result of a combination between plastic runner with step cut and elastomeric Q-ring (NBR) for energizing.

The high strength of the plastic material, grant the sealing effect at high pressure and permit higher radial clearance (Piston/ Bore) compare to other piston seals.

This last aspect allows for an easier machining of the piston.

Fields of applications: excavators, lifts, cranes and fork lifts.

Technical data

Pressure: < 800 bar (with peaks till 1000 bar)
 Speed: < 1 m/s
 Temperature: from - 30° C to + 110° C
 Fluids: mineral-based fluid and oil.
 (see table 3, page 14)

Material

Elastomeric ring in NBR 75 Shore A.
 Plastic Runner in modify PA66 material.

Assembling

The installation is simplified because the Runner has a cutting step.

The assembling in in closed groove after the installation of NBR energizing element.

Grease before the piston installation in the cylinder.

Note: do not use in static applications.

Fig. 37- Pic.37:

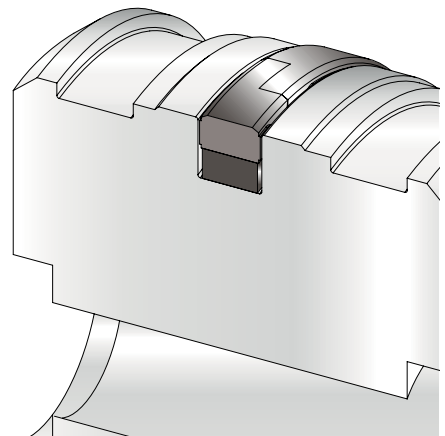



PSZ

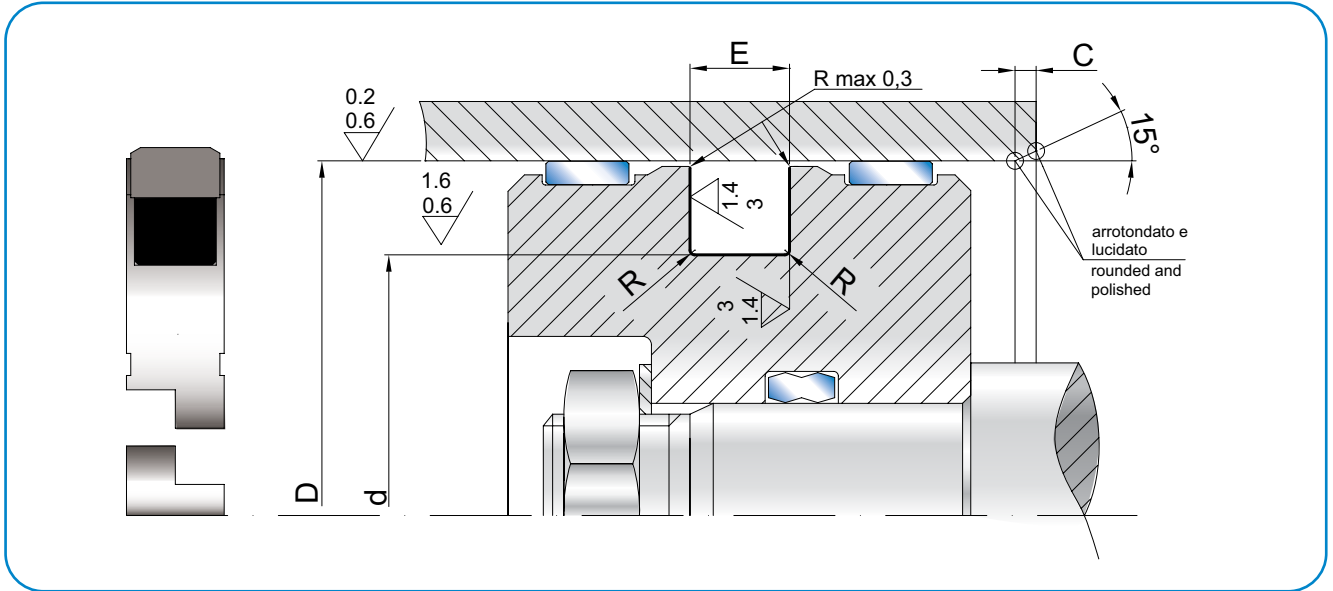
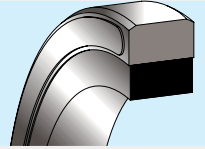

D _{H9}	d _{h9}	E _{+0,1}	R	C	ART / ITEM
45,0	34,0	4,2	0,3	5,0	PSZ 0450 0340 042 RN
50,0	34,5	6,3	0,3	5,0	PSZ 0500 0345 063 RN
50,0	39,0	4,2	0,3	5,0	PSZ 0500 0390 042 RN
60,0	49,0	4,2	0,3	5,0	PSZ 0600 0490 042 RN
63,0	47,5	6,3	0,3	5,0	PSZ 0630 0475 063 RN
70,0	54,5	6,3	0,5	5,0	PSZ 0700 0545 063 RN
70,0	59,0	4,2	0,5	5,0	PSZ 0700 0590 042 RN
75,0	59,5	6,3	0,5	5,0	PSZ 0750 0595 063 RN
75,0	54,0	8,1	0,5	5,0	PSZ 0750 0540 081 RN
80,0	59,0	8,1	0,5	5,0	PSZ 0800 0590 081 RN
85,0	69,5	6,3	0,5	5,0	PSZ 0850 0695 063 RN
90,0	69,0	8,1	0,5	5,0	PSZ 0900 0690 081 RN
95,0	79,5	6,3	0,5	5,0	PSZ 0950 0795 063 RN
100,0	79,0	8,1	0,5	5,0	PSZ 1000 0790 081 RN
110,0	89,0	8,1	0,5	5,0	PSZ 1100 0890 081 RN

D _{H9}	d _{h9}	E _{+0,1}	R	C	ART / ITEM
120,0	99,0	8,1	0,5	5,0	PSZ 1200 0990 081 RN
125,0	104,0	8,1	0,6	6,5	PSZ 1250 1040 081 RN
125,0	109,5	6,3	0,6	6,5	PSZ 1250 1095 063 RN
130,0	109,0	8,1	0,6	6,5	PSZ 1300 1090 081 RN
140,0	119,0	8,1	0,6	6,5	PSZ 1400 1190 081 RN
150,0	129,0	8,1	0,6	6,5	PSZ 1500 1290 081 RN
160,0	139,0	8,1	0,6	6,5	PSZ 1600 1390 081 RN
170,0	149,0	8,1	0,6	6,5	PSZ 1700 1490 081 RN
180,0	159,0	8,1	0,6	6,5	PSZ 1800 1590 081 RN
190,0	169,0	8,1	0,6	6,5	PSZ 1900 1690 081 RN
200,0	179,0	8,1	0,6	6,5	PSZ 2000 1790 081 RN

Nota: altre dimensioni non a catalogo a richiesta. Consultare il nostro ufficio tecnico.

Remark: please contact our technical dept. for further dimensions not included in the catalogue.

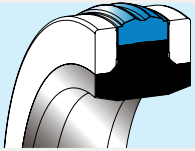

PHP

TENUTA PISTONE TIPO PHP

Descrizione

La tenuta pistone PHP è studiata per cilindri a doppio effetto dove le pressioni e le condizioni di lavoro sono molto gravose. È composta da tre elementi:

- parte statica con funzione energizzante
- parte centrale dinamica con funzione di tenuta assiale
- anelli laterali antiestrusione che consentono un gioco radiale maggiore tra pistone e camicia del cilindro.

Utilizzata sui cilindri macchine movimento terra, macchine di sollevamento e presse.

Limiti d'impiego

Pressione: < 400 bar (con materiale TPU)
< 600 bar (con materiale PTFE)

Velocità: < 0.8 m/s (con materiale TPU)
< 1.5 m/s (con materiale PTFE)

Temperatura: da - 35 °C a +100°C (con punte fino a 110°C con materiale TPU)
da -35°C a + 150° (con materiale PTFE)

Fluidi: fluidi e oli a base minerale (v. tabella 3 a p. 14)

Materiale

- anello espansore statico in NBR 80 Shore A
- anello di tenuta dinamica in TPU 93 Shore A (standard per pressioni fino a 300 [bar])
- anello di tenuta dinamica in TPU 98 Shore A (standard per pressioni fino a 400 [bar])
- anello di tenuta dinamica in PTFE (per pressioni fino a 600 [bar] e alte velocità)
- anelli antiestrusione in materiale termoplastico (POM oppure TPE).

Montaggio

Il montaggio può avvenire sia su pistone monoblocco sia su pistone in due parti.

Sequenza del montaggio:

- elemento in gomma
- elemento in poliuretano o in PTFE
- anelli antiestrusione.

Togliere gli spigoli vivi e le bave di lavorazione per evitare di danneggiare la tenuta durante il montaggio.

PHP TYPE PISTON SEAL

Description

The PHP piston seal is design for double effect cylinder where the pressure and working conditions are heavy.

It is composed by three elements:

- static Part that has energizing function
- central Dynamic part has axial sealing function
- lateral antiextrusion Ring allow a greater radial clearance between piston and bore cylinder.

Cylinders used on earth moving machines, lifting machines and presses.

Technical data

Pressure: < 400 bar (With TPU material)
< 600 bar (With PTFE material)

Speed: < 0.8 m/s (With TPU material)
< 1.5 m/s (With PTFE material)

Temperature: from - 35 °C to +100°C (with peaks till 110°C with TPU material)
da -35°C a + 150° (with PTFE material)

Fluids: mineral-based fluid and oil.
(see table 3, page 14)

Material

- static energizing ring in NBR 80 Shore A
- dynamic seal in TPU 93 Shore A (standard for pressure until 300 [bar])
- dynamic seal in TPU 98 Shore A (standard for pressure until 400 [bar])
- dynamic seal in PTFE (for pressure until 600 [bar] e high speed)
- anti-extrusion Ring in thermoplastic material (POM or TPE).

Assembling

The assembling can be on monoblock or two-parts piston.

Assembling sequence:

- NBR element
- polyurethane or PTFE element
- anti-extrusion ring.

Eliminate sharp edges and burrs to avoid damaging the seal during assembly.



PHP

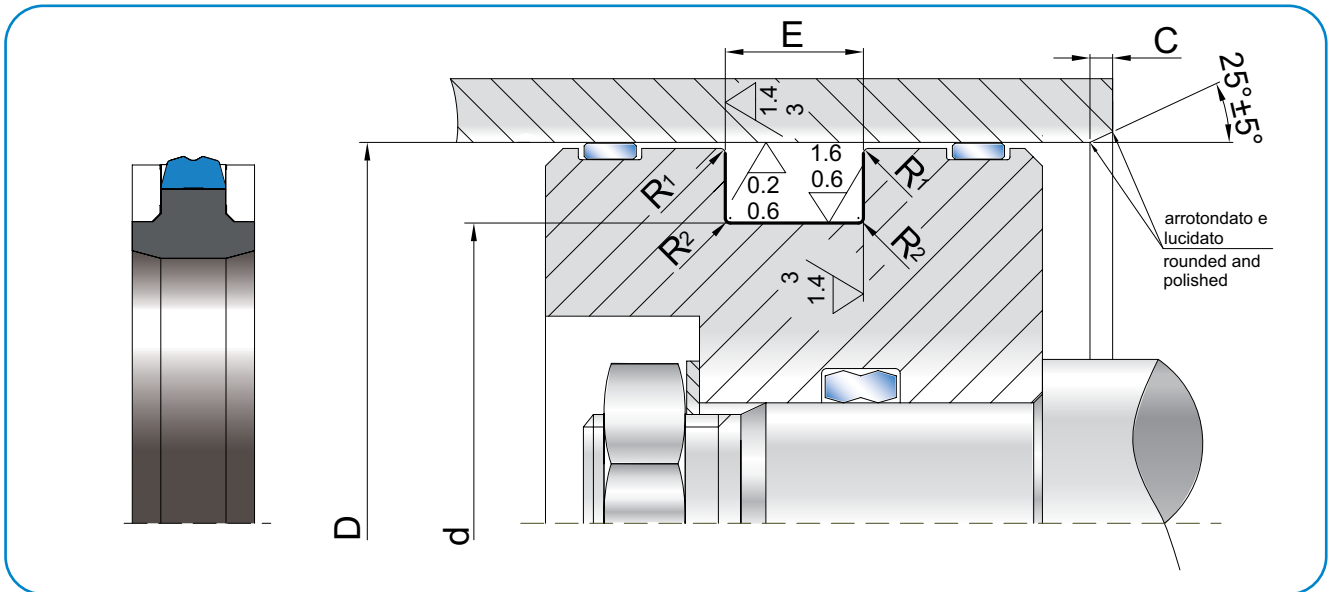
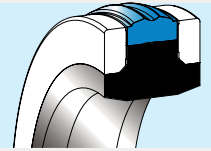

D _{H9}	d _{h9}	E _{+0,2}	R ₁	R ₂	C	ART / ITEM
40,0	30,0	8,0	0,1	0,3	5,0	PHP 0400 0300 080 CX
50,0	36,0	9,0	0,1	0,3	5,0	PHP 0500 0360 090 CX
55,0	41,0	9,0	0,1	0,3	5,0	PHP 0550 0410 090 CX
60,0	46,0	9,0	0,1	0,3	5,0	PHP 0600 0460 090 CX
63,0	48,0	11,0	0,1	0,5	5,0	PHP 0630 0480 110 CX
65,0	50,0	11,0	0,1	0,5	5,0	PHP 0650 0500 110 CX
70,0	55,0	11,0	0,1	0,5	5,0	PHP 0700 0550 110 CX
75,0	60,0	11,0	0,1	0,5	5,0	PHP 0750 0600 110 CX
80,0	65,0	11,0	0,1	0,5	5,0	PHP 0800 0650 110 CX
85,0	70,0	11,0	0,1	0,5	5,0	PHP 0850 0700 110 CX
90,0	75,0	11,0	0,1	0,5	5,0	PHP 0900 0750 110 CX
95,0	80,0	12,5	0,1	0,5	5,0	PHP 0950 0800 125 CX
100,0	85,0	12,5	0,1	0,5	5,0	PHP 1000 0850 125 CX
105,0	90,0	12,5	0,2	0,5	5,0	PHP 1050 0900 125 CX
110,0	95,0	12,5	0,2	0,5	5,0	PHP 1100 0950 125 CX

D _{H9}	d _{h9}	E _{+0,2}	R ₁	R ₂	C	ART / ITEM
115,0	100,0	12,5	0,2	0,5	5,0	PHP 1150 1000 125 CX
120,0	105,0	12,5	0,2	0,5	5,0	PHP 1200 1050 125 CX
125,0	102,0	16,0	0,2	0,6	6,5	PHP 1250 1020 160 CX
130,0	107,0	16,0	0,2	0,6	6,5	PHP 1300 1070 160 CX
135,0	112,0	16,0	0,2	0,6	6,5	PHP 1350 1120 160 CX
140,0	117,0	16,0	0,2	0,6	6,5	PHP 1400 1170 160 CX
145,0	122,0	16,0	0,2	0,6	6,5	PHP 1450 1220 160 CX
150,0	127,0	16,0	0,2	0,6	6,5	PHP 1500 1270 160 CX
155,0	132,0	16,0	0,2	0,6	6,5	PHP 1550 1320 160 CX
160,0	137,0	16,0	0,2	0,6	6,5	PHP 1600 1370 160 CX
165,0	142,0	16,0	0,2	0,6	6,5	PHP 1650 1420 160 CX
170,0	147,0	16,0	0,2	0,6	6,5	PHP 1700 1470 160 CX
180,0	157,0	16,0	0,2	0,6	6,5	PHP 1800 1570 160 CX

Nota: altre dimensioni non a catalogo a richiesta. Consultare il nostro ufficio tecnico.

Remark: please contact our technical dept. for further dimensions not included in the catalogue.

Fig. 38 - Pic.38:

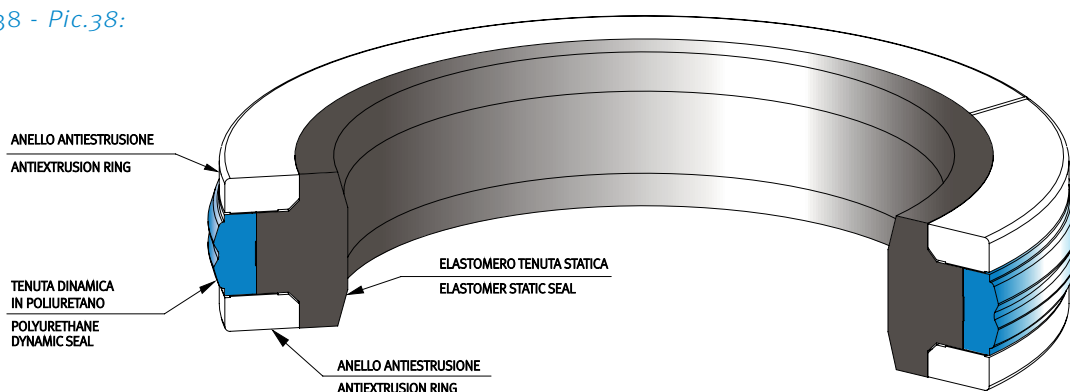

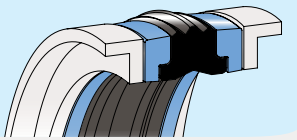

KDSA

TENUTA PISTONE COMPATTA TIPO KDSA

Descrizione

La tenuta pistone compatta tipo KDSA è costituita da un elemento centrale in gomma nitrilica che esercita la funzione di tenuta, da due supporti laterali all'elemento in gomma che agiscono da anelli antiestrusione e da due guide esterne che mantengono in guida il pistone nel cilindro.

Dati tecnici

Pressione: da 0 a 400
 Velocità: < 0.5 m/s
 Temperatura: da - 30 °C a +100 °C
 Fluidi: oli a base minerale
 (v. tabella 3 a p. 14)

Materiale

I materiali utilizzati per questa tenuta sono:

- NBR con durezza 70 Shore A \pm 3 per l'elemento centrale
- elastomero termoplastico (TPE) per i supporti laterali
- resina poliacetalica le guide esterne (POM).

Codice materiale standard: CX

Montaggio

Il montaggio di questa tenuta è eseguibile sia in cava chiusa su pistone monoblocco sia in cava aperta su pistone in due pezzi.

L'ordine del montaggio deve essere il seguente:

- elemento in gomma
- supporti
- guide.

È necessario che il pistone non presenti bave di lavorazione meccanica che danneggerebbero l'elemento in gomma durante il montaggio.

KDSA TYPE COMPACT PISTON SEAL

Description

The KDSA compact seal is made of a central unit made of NBR working as a seal, two sides supports, working as anti extrusion ring, and two external guide rings, keeping aligned the piston in the cylinder.

Technical data

Pressure: from 0 to 400
 Speed: < 0.5 m/s
 Temperature: from - 30 °C at +100 °C
 Fluids: Mineral oils
 (see table 3, page 14)

Material

The compounds used to manufacture this seal type are:

- the central units is made of NBR, the hardness is 70 Shore A \pm 3
- the sides support are made of thermoplastic elastomer (TPE)
- the external wear rings are made of polyacetal resin (POM).

Compound reference: CX

Assembling

The assembling of this seal can be carried out in either closed groove in a mono-block piston, or in open groove in a two-parts piston.

The assembling has to be done as follows:

- rubber element
- supports
- wear rings.

The piston must not have machining scores which may damage the rubber unit during the installation.



KDSA

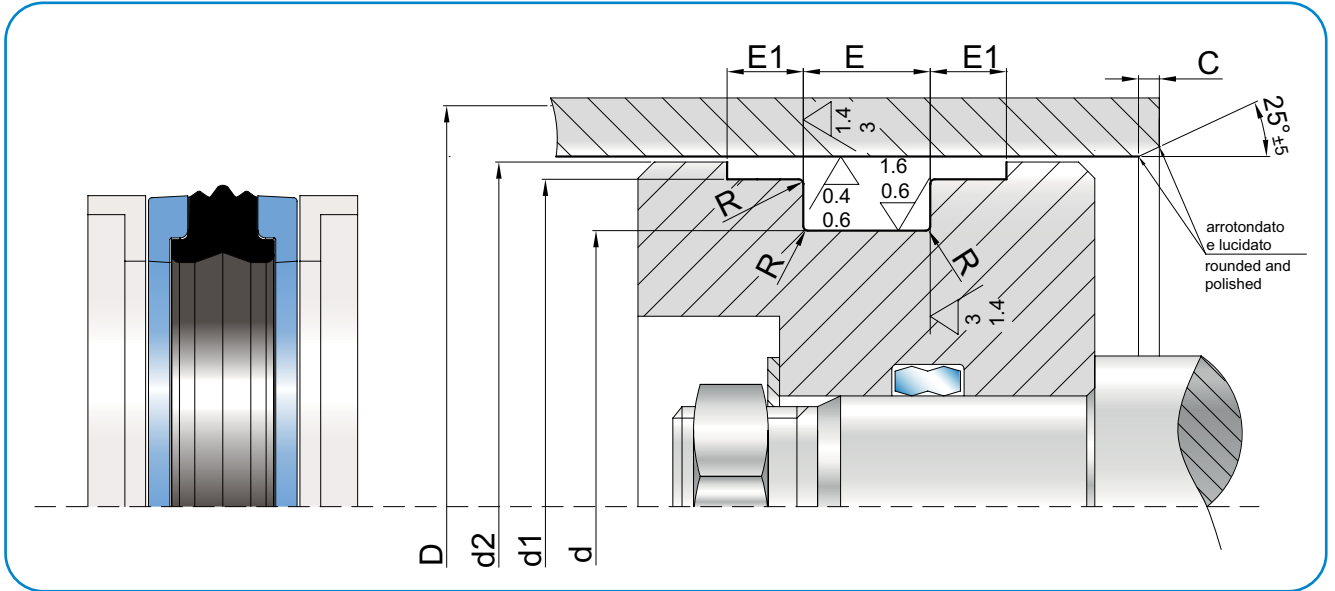
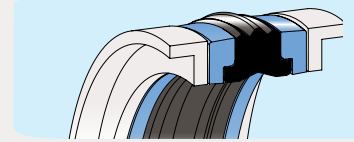

D _{H9}	d _{H9}	E _{+0,2}	d _{1H9}	d _{2±0,2}	E _{1 0/+0,1}	R	C	ART / ITEM
32,0	24,0	15,5	28,0	31,4	3,2	0,4	3,5	KDSA 0320 0240 155 CX
40,0	32,0	15,5	36,0	39,4	3,2	0,4	4,0	KDSA 0400 0320 155 CX
50,0	38,0	20,5	46,0	49,4	4,2	0,4	4,0	KDSA 0500 0380 205 CX
60,0	48,0	20,5	56,0	59,4	4,2	0,4	4,5	KDSA 0600 0480 205 CX
63,0	51,0	20,5	59,0	62,4	4,2	0,4	4,5	KDSA 0630 0510 205 CX
70,0	58,0	20,5	66,0	69,4	4,2	0,4	4,5	KDSA 0700 0580 205 CX
80,0	66,0	22,5	76,0	79,4	5,2	0,4	4,5	KDSA 0800 0660 225 CX
90,0	76,0	22,5	86,0	89,4	5,2	0,4	4,5	KDSA 0900 0760 225 CX
100,0	86,0	22,5	96,0	99,4	5,2	0,4	5,0	KDSA 1000 0860 225 CX
110,0	96,0	22,5	106,0	109,4	5,2	0,4	5,0	KDSA 1100 0960 225 CX
120,0	106,0	22,5	116,0	119,4	5,2	0,8	5,0	KDSA 1200 1060 225 CX
125,0	108,0	26,5	121,0	124,4	7,2	0,8	5,0	KDSA 1250 1080 265 CX
130,0	113,0	26,5	126,0	129,4	7,2	0,8	5,0	KDSA 1300 1130 265 CX
140,0	123,0	26,5	136,0	139,4	7,2	0,8	5,0	KDSA 1400 1230 265 CX
150,0	133,0	26,5	146,0	149,4	7,2	0,8	5,0	KDSA 1500 1330 265 CX
160,0	143,0	26,5	156,0	159,4	7,2	0,8	5,0	KDSA 1600 1430 265 CX

Nota: altre dimensioni non a catalogo a richiesta. Consultare il nostro ufficio tecnico.

Remark: please contact our technical dept. for further dimensions not included in the catalogue.

Oleodinamica
Hydraulic

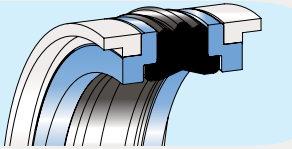

KDSB

TENUTA PISTONE COMPATTA TIPO KDSB

Descrizione

La tenuta pistone compatta tipo KDSB è costituita da un elemento centrale in gomma nitrilica che esercita la funzione di tenuta, da due supporti laterali all'elemento in gomma che agiscono da anelli antiestrusione e da due guide esterne che mantengono in guida il pistone nel cilindro.

Dati tecnici

Pressione: da 0 a 400
 Velocità: < 0.5 m/s
 Temperatura: da - 30 °C a +100 °C
 Fluidi: oli a base minerale
 (v. tabella 3 a p. 14)

Materiale

I materiali utilizzati per questa tenuta sono:

- NBR con durezza 70 Shore A \pm 3 per l'elemento centrale
- elastomero termoplastico (TPE) per i supporti laterali
- resina poliacetalica le guide esterne (POM).

Codice materiale standard: CX

Montaggio

Il montaggio può essere eseguito sia in cava chiusa su pistone monoblocco sia in cava aperta su pistone in due pezzi.

L'ordine del montaggio deve essere il seguente:

- elemento in gomma
- supporti
- guide.

È necessario che il pistone non presenti bave di lavorazione meccanica che danneggerebbero l'elemento in gomma durante il montaggio.

KDSB TYPE COMPACT PISTON SEAL

Description

The KDSB compact seal is made of a central unit in NBR working as a seal, two side supports, working as anti extrusion ring, and two external guide rings, keeping aligned the piston in the cylinder.

Technical data

Pressure: from 0 to 400
 Speed: < 0.5 m/s
 Temperature: from - 30 °C at +100 °C
 Fluids: Mineral oils
 (see table 3, page 14)

Material

The compounds used to manufacture this seal type are the following:

- the central units is made of NBR, the hardness is 70 Shore A \pm 3
- the sides support are made of a thermoplastic elastomer (TPE)
- the external wear rings are made of polyacetal resin (POM).

Compound reference: CX

Assembling

The assembling of this seal can be carried out in either closed groove in a mono-block piston, or in open groove in a two-parts piston.

The assembling has to be done as follows:

- rubber element
- supports
- wear rings.

Avoid machining scores on the piston which may damage the rubber unit during the installation.



KDSB

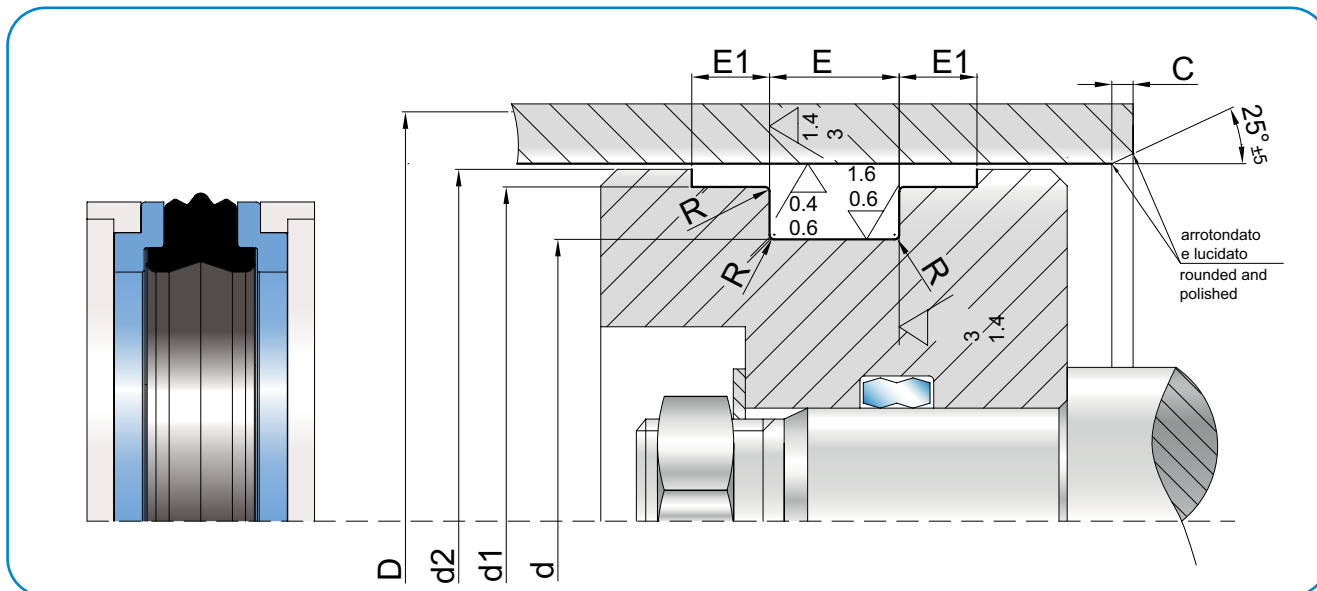
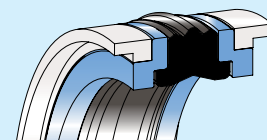

Oleodinamica
Hydraulic

D _{H9}	d _{H9}	E _{+0,2}	d _{1H9}	d _{2±0,2}	E _{1 +0,1}	R	C	ART / ITEM
20,0	11,0	13,5	17,00	19,0	2,10	0,4	3,5	KDSB 0200 0110 135 CX
22,0	13,0	13,5	19,00	21,0	2,10	0,4	3,5	KDSB 0220 0130 135 CX
25,0	15,0	12,0	21,00	23,0	4,00	0,4	3,5	KDSB 0250 0150 120 CX
25,0	15,0	12,5	22,00	24,0	4,00	0,4	3,5	KDSB 0250 0150 125 CX
25,0	15,0	16,4	21,45	23,5	6,35	0,4	3,5	KDSB 0250 0150 164 CX
25,0	16,0	13,5	22,00	24,0	2,10	0,4	3,5	KDSB 0250 0160 135 CX
28,0	19,0	13,5	25,00	27,0	2,10	0,4	3,5	KDSB 0280 0190 135 CX
30,0	21,0	13,5	27,00	29,0	2,10	0,4	3,5	KDSB 0300 0210 135 CX
32,0	22,0	15,5	28,00	31,0	2,60	0,4	3,5	KDSB 0320 0220 155 CX
32,0	22,0	16,4	28,50	30,5	6,35	0,4	3,5	KDSB 0320 0220 164 CX
35,0	25,0	15,5	31,00	34,0	2,60	0,4	3,5	KDSB 0350 0250 155 CX
35,0	25,0	16,4	31,40	33,5	6,35	0,4	3,5	KDSB 0350 0250 164 CX
40,0	24,0	18,4	35,40	38,5	6,35	0,4	4,0	KDSB 0400 0240 184 CX
40,0	26,0	15,5	36,00	39,0	2,60	0,4	4,0	KDSB 0400 0260 155 CX
40,0	30,0	12,5	36,00	38,0	4,00	0,4	4,0	KDSB 0400 0300 125 CX
40,0	30,0	16,4	35,40	38,5	6,35	0,4	4,0	KDSB 0400 0300 164 CX
42,0	28,0	15,5	38,00	41,0	2,60	0,4	4,0	KDSB 0420 0280 155 CX
45,0	29,0	18,4	40,40	43,5	6,35	0,4	4,0	KDSB 0450 0290 184 CX
45,0	31,0	15,5	41,00	44,0	2,60	0,4	4,0	KDSB 0450 0310 155 CX
45,0	35,0	16,4	40,40	43,5	6,35	0,4	4,0	KDSB 0450 0350 164 CX
50,0	34,0	18,4	45,40	48,5	6,35	0,4	4,0	KDSB 0500 0340 184 CX
50,0	34,0	20,5	46,00	49,0	3,10	0,4	4,0	KDSB 0500 0340 205 CX
55,0	39,0	18,4	50,36	53,5	6,35	0,4	4,0	KDSB 0550 0390 184 CX
55,0	39,0	20,5	51,00	54,0	3,10	0,4	4,0	KDSB 0550 0390 205 CX
56,0	40,0	20,5	52,00	55,0	3,10	0,4	4,0	KDSB 0560 0400 205 CX
60,0	44,0	18,4	55,40	58,5	6,35	0,4	4,5	KDSB 0600 0440 184 CX
60,0	44,0	20,5	56,00	59,0	3,10	0,4	4,5	KDSB 0600 0440 205 CX

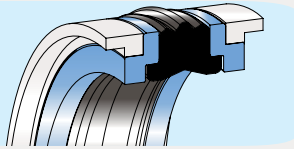

KDSB

D _{H9}	d _{h9}	E _{+0,2}	d _{1h9}	d _{2±0,2}	E _{1 +0,1}	R	C	ART / ITEM
63,0	47,0	18,4	58,40	61,5	6,35	0,4	4,5	KDSB 0630 0470 184 CX
63,0	47,0	19,4	58,40	61,5	6,35	0,4	4,5	KDSB 0630 0470 194 CX
63,0	47,0	20,5	59,00	62,0	3,10	0,4	4,5	KDSB 0630 0470 205 CX
65,0	49,0	20,5	61,00	64,0	3,10	0,4	4,5	KDSB 0650 0490 205 CX
65,0	50,0	18,4	60,40	63,5	6,35	0,4	4,5	KDSB 0650 0500 184 CX
65,0	53,0	20,5	61,0	63,5	4,10	0,4	4,5	KDSB 0650 0530 205 CX
70,0	50,0	22,4	64,20	68,3	6,35	0,4	4,5	KDSB 0700 0500 224 CX
70,0	54,0	20,5	66,00	69,0	3,10	0,4	4,5	KDSB 0700 0540 205 CX
75,0	55,0	22,4	69,20	73,3	6,35	0,4	4,5	KDSB 0750 0550 224 CX
75,0	59,0	20,5	71,00	74,0	3,10	0,4	4,5	KDSB 0750 0590 205 CX
80,0	60,0	22,4	74,15	78,3	6,35	0,4	4,5	KDSB 0800 0600 224 CX
80,0	62,0	22,5	76,00	79,0	3,60	0,4	4,5	KDSB 0800 0620 225 CX
85,0	65,0	22,4	79,15	83,3	6,35	0,4	4,5	KDSB 0850 0650 224 CX
90,0	70,0	22,4	84,15	88,3	6,35	0,4	4,5	KDSB 0900 0700 224 CX
90,0	72,0	22,5	86,00	89,0	3,60	0,4	4,5	KDSB 0900 0720 225 CX
95,0	75,0	22,4	89,15	93,3	6,35	0,4	4,5	KDSB 0950 0750 224 CX
100,0	75,0	22,4	93,15	98,0	6,35	0,4	5,0	KDSB 1000 0750 224 CX
100,0	82,0	22,5	96,00	99,0	3,60	0,4	5,0	KDSB 1000 0820 225 CX
105,0	80,0	22,4	98,10	103,0	6,35	0,4	5,0	KDSB 1050 0800 224 CX
110,0	85,0	22,4	103,10	108,0	6,35	0,4	5,0	KDSB 1100 0850 224 CX
110,0	92,0	22,5	106,00	109,0	3,60	0,4	5,0	KDSB 1100 0920 225 CX
115,0	90,0	22,4	108,10	113,0	6,35	0,4	5,0	KDSB 1150 0900 224 CX
115,0	97,0	22,5	111,00	114,0	3,60	0,4	5,0	KDSB 1150 0970 225 CX
120,0	95,0	22,4	113,10	118,1	6,35	0,8	5,0	KDSB 1200 0950 224 CX
125,0	100,0	25,4	118,10	123,0	6,35	0,8	5,0	KDSB 1250 1000 254 CX
125,0	103,0	26,5	121,00	124,0	5,10	0,8	5,0	KDSB 1250 1030 265 CX
130,0	105,0	25,4	122,60	127,5	9,50	0,8	5,0	KDSB 1300 1050 254 CX
130,0	105,0	25,4	123,10	128,0	6,35	0,8	5,0	KDSB1 1300 1050 254 CX
135,0	110,0	25,4	127,60	132,5	9,50	0,8	5,0	KDSB 1350 1100 254 CX
135,0	110,0	25,4	128,10	133,0	6,35	0,8	5,0	KDSB1 1350 1100 254 CX
140,0	115,0	25,4	132,60	137,5	9,50	0,8	5,0	KDSB 1400 1150 254 CX
140,0	115,0	25,4	133,00	138,0	6,35	0,8	5,0	KDSB1 1400 1150 254 CX
140,0	118,0	26,5	136,00	139,0	5,10	0,8	5,0	KDSB 1400 1180 265 CX
145,0	120,0	25,4	137,60	142,5	9,50	0,8	5,0	KDSB 1450 1200 254 CX
145,0	120,0	25,4	138,30	143,0	6,35	0,8	5,0	KDSB1 1450 1200 254 CX
150,0	125,0	25,4	142,60	147,5	9,50	0,8	5,0	KDSB 1500 1250 254 CX
150,0	125,0	25,4	143,00	148,0	6,35	0,8	5,0	KDSB1 1500 1250 254 CX
150,0	128,0	26,5	146,00	149,0	5,10	0,8	5,0	KDSB 1500 1280 265 CX
155,0	130,0	25,4	147,60	152,5	9,50	0,8	5,0	KDSB 1550 1300 254 CX
155,0	130,0	25,4	148,00	153,0	6,35	0,8	5,0	KDSB1 1550 1300 254 CX
160,0	130,0	25,4	153,00	157,5	6,35	0,8	5,0	KDSB1 1600 1300 254 CX
160,0	130,0	25,4	152,60	157,5	9,50	0,8	5,0	KDSB 1600 1300 254 CX
160,0	135,0	25,4	152,60	157,5	9,50	0,8	5,0	KDSB 1600 1350 254 CX
160,0	138,0	26,5	156,00	159,0	5,10	0,8	5,0	KDSB 1600 1380 265 CX
165,0	140,0	25,4	157,60	162,5	9,50	0,8	5,0	KDSB 1650 1400 254 CX



KDSB

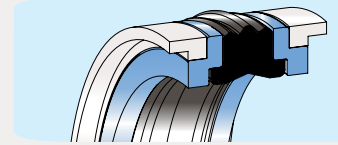

D _{H9}	d _{h9}	E _{+0,2}	d _{1h9}	d _{2±0,2}	E _{1 +0,1}	R	C	ART / ITEM				
170,0	145,0	25,4	161,70	167,1	12,70	0,8	5,0	KDSB	1700	1450	254	CX
170,0	148,0	26,5	166,00	169,0	5,10	0,8	5,0	KDSB	1700	1480	265	CX
175,0	150,0	25,4	166,70	172,1	12,70	0,8	5,0	KDSB	1750	1500	254	CX
180,0	150,0	35,4	172,95	177,9	6,35	0,8	5,0	KDSB	1800	1500	354	CX
180,0	155,0	25,4	171,70	177,1	12,70	0,8	5,0	KDSB	1800	1550	254	CX
185,0	160,0	25,4	176,70	182,1	12,70	0,8	5,0	KDSB	1850	1600	254	CX
190,0	165,0	25,4	181,70	187,0	12,70	0,8	5,0	KDSB	1900	1650	254	CX
195,0	170,0	25,4	186,70	192,0	12,70	0,8	5,0	KDSB	1950	1700	254	CX
200,0	175,0	25,4	191,60	197,0	12,70	0,8	6,0	KDSB	2000	1750	254	CX
200,0	180,0	31,5	196,00	198,0	9,20	0,8	6,0	KDSB	2000	1800	315	CX
210,0	185,0	25,4	201,60	207,0	12,70	0,8	6,0	KDSB	2100	1850	254	CX
220,0	190,0	35,4	212,70	217,9	6,35	0,8	6,0	KDSB	2200	1900	354	CX
220,0	195,0	25,4	211,60	217,0	12,70	0,8	6,0	KDSB	2200	1950	254	CX
230,0	205,0	25,4	221,60	227,0	12,70	0,8	6,0	KDSB	2300	2050	254	CX
240,0	215,0	25,4	231,60	237,0	12,70	0,8	6,0	KDSB	2400	2150	254	CX
250,0	220,0	35,4	242,90	247,9	6,35	0,8	6,0	KDSB	2500	2200	354	CX
250,0	225,0	25,4	241,60	247,0	12,70	0,8	6,0	KDSB	2500	2250	254	CX

Nota: altre dimensioni non a catalogo a richiesta. Consultare il nostro ufficio tecnico.

Remark: please contact our technical dept. for further dimensions not included in the catalogue.

Dimensioni in pollici / Inch sizes

D _{H9}		d _{h9}		E _{+0,2}		d _{1h9}		d _{2±0,2}		E _{1 +0,1}		R		C		ART / ITEM				
inch	mm	inch	mm	inch	mm	inch	mm	inch	mm	inch	mm	inch	mm	inch	mm					
2,000	50,80	1,375	38,10	0,750	19,05	1,820	46,23	1,948	49,42	0,250	6,35	0,015	0,4	0,157	4,0	KDSI	2000	1375	0750	CX
2,375	60,33	1,750	44,45	0,750	19,05	2,194	55,73	2,322	58,98	0,250	6,35	0,015	0,4	0,177	4,5	KDSI	2375	1750	0750	CX
2,500	63,50	1,875	47,62	0,750	19,05	2,318	58,90	2,445	62,12	0,250	6,35	0,015	0,4	0,177	4,5	KDSI	2500	1875	0750	CX
3,000	76,20	2,250	57,15	0,937	23,79	2,771	70,40	2,933	74,50	0,250	6,35	0,015	0,4	0,177	4,5	KDSI	3000	2250	0937	CX
3,500	88,90	2,750	69,85	0,937	23,79	3,270	83,08	3,433	87,22	0,250	6,35	0,015	0,4	0,177	4,5	KDSI	3500	2750	0937	CX
4,000	101,60	3,250	82,55	0,937	23,79	3,770	95,78	3,933	99,92	0,250	6,35	0,015	0,4	0,196	5,0	KDSI	4000	3250	0937	CX

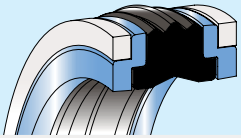

KDSB/AE

TENUTA PISTONE COMPATTA TIPO KDSB/AE

Descrizione

La tenuta pistone compatta tipo KDSB/AE è costituita da un elemento centrale in gomma nitrilica che esercita la funzione di tenuta, da due supporti laterali all'elemento in gomma, e da due anelli antiestrusione.

Diversamente dalla KDSB il pistone nel cilindro deve essere progettato prevedendo gli elementi di guida.

Dati tecnici

Pressione: da 0 a 400
 Velocità: < 0.5 m/s
 Temperatura: da - 30 °C a +100 °C
 Fluidi: oli a base minerale
 (v. tabella 3 a p. 14)

Materiale

I materiali utilizzati per questa tenuta sono:

- NBR con durezza 70 Shore A \pm 3 per l'elemento centrale
- elastomero termoplastico (TPE) per i supporti laterali
- resina poliacetalica le guide esterne (POM).

Codice materiale standard: CX

Montaggio

Il montaggio può essere eseguito sia in cava chiusa su pistone monoblocco sia in cava aperta su pistone in due pezzi.

L'ordine del montaggio deve essere il seguente:

- elemento in gomma
- supporti
- guide.

È necessario che il pistone non presenti bave di lavorazione meccanica che danneggerebbero l'elemento in gomma durante il montaggio.

KDSB/AE TYPE COMPACT PISTON SEAL

Description

The KDSB/AE compact piston seal combines a central NBR unit working as a pressure seal supported by two side elements and two anti-extrusion rings. The KDSB/AE requires the addition of wear rings housed wither side of the seal.

Technical data

Pressure: from 0 to 400
 Speed: < 0.5 m/s
 Temperature: from - 30 °C at +100 °C
 Fluids: Mineral oils
 (see table 3, page 14)

Material

The compounds used to manufacture this seal type are the following:

- the central units is made of NBR, the hardness is 70 Shore A \pm 3
- the sides support are made of a thermoplastic elastomer (TPE)
- the external wear rings are made of polyacetal resin (POM).

Compound reference: CX

Assembling

The assembling of this seal can be carried out in either closed groove in a mono-block piston, or in open groove in a two-parts piston.

The assembling has to be done as follows:

- rubber element
- supports
- wear rings.

Avoid machining scores on the piston which may damage the rubber unit during the installation.



KDSB/AE

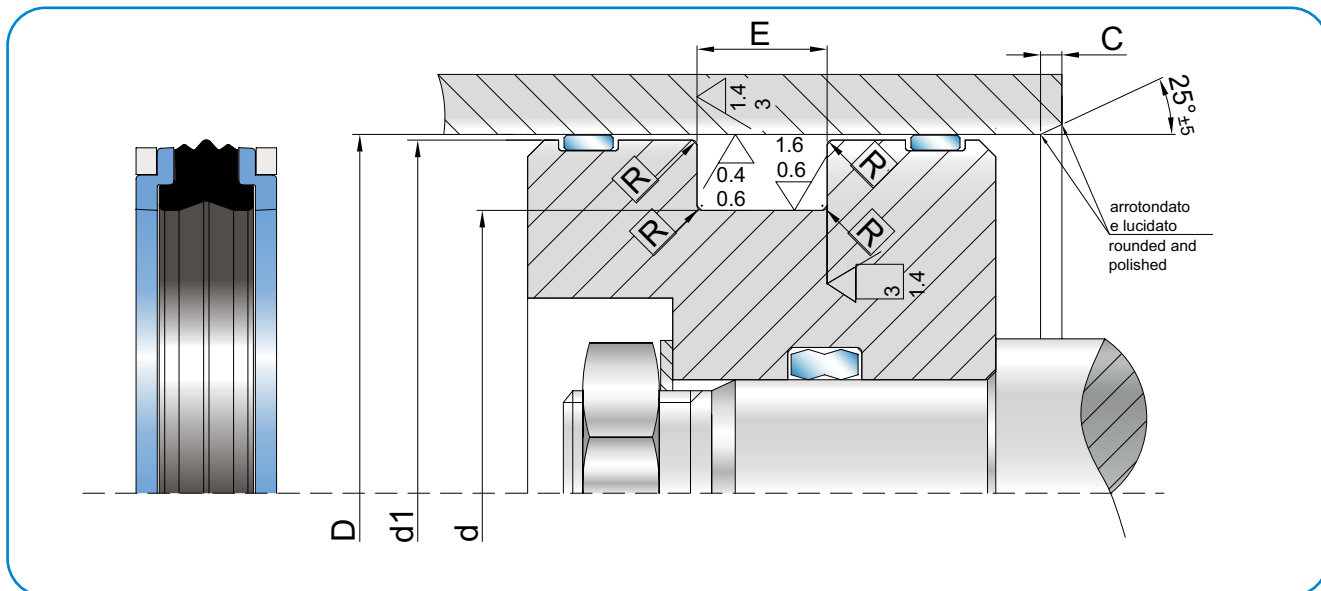
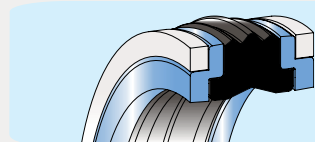

Oleodinamica
Hydraulic

D _{H9}	d _{H9}	E _{+0,2}	d _{1H9}	R	C	ART / ITEM				
40,0	30,0	16,4	38,5	0,4	4,0	KDSB/AE	0400	0300	164	CX
45,0	35,0	16,4	43,5	0,4	4,0	KDSB/AE	0450	0350	164	CX
50,0	34,0	18,4	48,5	0,4	4,0	KDSB/AE	0500	0340	184	CX
60,0	44,0	18,4	58,5	0,4	4,5	KDSB/AE	0600	0440	184	CX
63,0	47,0	18,4	61,5	0,4	4,5	KDSB/AE	0630	0470	184	CX
70,0	50,0	22,4	68,3	0,4	4,5	KDSB/AE	0700	0500	224	CX
75,0	55,0	22,4	73,3	0,4	4,5	KDSB/AE	0750	0550	224	CX
80,0	60,0	22,4	78,3	0,4	4,5	KDSB/AE	0800	0600	224	CX
85,0	65,0	22,4	83,3	0,4	4,5	KDSB/AE	0850	0650	224	CX
90,0	70,0	22,4	88,3	0,4	4,5	KDSB/AE	0900	0700	224	CX
95,0	75,0	22,4	93,3	0,4	4,5	KDSB/AE	0950	0750	224	CX
100,0	75,0	22,4	98,0	0,4	5,0	KDSB/AE	1000	0750	224	CX
110,0	85,0	22,4	108,0	0,4	5,0	KDSB/AE	1100	0850	224	CX
120,0	95,0	22,4	118,1	0,8	5,0	KDSB/AE	1200	0950	224	CX
125,0	100,0	25,4	123,0	0,8	5,0	KDSB/AE	1250	1000	254	CX
130,0	105,0	25,4	127,5	0,8	5,0	KDSB/AE	1300	1050	254	CX
135,0	110,0	25,4	132,5	0,8	5,0	KDSB/AE	1350	1100	254	CX
140,0	115,0	25,4	137,5	0,8	5,0	KDSB/AE	1400	1150	254	CX
150,0	125,0	25,4	147,5	0,8	5,0	KDSB/AE	1500	1250	254	CX
160,0	135,0	25,4	157,5	0,8	5,0	KDSB/AE	1600	1350	254	CX
170,0	145,0	25,4	167,1	0,8	5,0	KDSB/AE	1700	1450	254	CX
180,0	155,0	25,4	177,1	0,8	5,0	KDSB/AE	1800	1550	254	CX
200,0	175,0	25,4	197,0	0,8	6,0	KDSB/AE	2000	1750	254	CX
210,0	185,0	25,4	207,0	0,8	6,0	KDSB/AE	2100	1850	254	CX

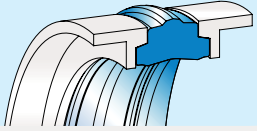

KDSP

TENUTA PISTONE COMPATTA TIPO KDSP

Descrizione

La guarnizione KDSP nasce per tenuta pistone con sedi intercambiabili ISO 6547.

È composta da soli tre elementi: quello centrale in poliuretano (con funzione di tenuta) e due guide laterali in poliacetalica rinforzata vetro.

Questo sistema permette di eliminare i supporti antiestrusione in quanto l'elemento centrale, grazie al suo alto modulo elastico, ha una durezza superiore alla gomma nitrilica NBR.

L'attrito di primo distacco e in esercizio si mantiene basso per la particolare geometria della guarnizione.

Dati tecnici

Pressione: da 0 a 400

Velocità: 0,8 m/s

Temperatura: da -30° C a +100° C

Fluidi: oli a base minerale
(v. tabella 3 a p. 14)

Materiale

I materiali utilizzati per la guarnizione KDSP sono:

- poliuretano di durezza 93 Shore A Codice materiale tipo Co per l'elemento centrale
- poliacetalica caricata vetro (POM) per gli elementi laterali.

Codice materiale: CX

Montaggio

Il montaggio di questa tenuta può essere eseguito sia in cava chiusa su pistone monoblocco sia in cava aperta su pistone in due pezzi. È necessario che il pistone non presenti bave di lavorazione meccanica che danneggerebbero l'elemento di tenuta durante il montaggio.

KDSP TYPE COMPACT PISTON SEAL

Description

The KDSP seal is designed to be a piston seal with interchangeable seats ISO 6547.

It consists of only three elements: a polyurethane seal at the middle and two side wear rings in glass-filled polyacetal resin.

This system doesn't need anti-extrusion supports, Thanks to the high modulus of elasticity and the hardness of the central element, which has higher hardness than Nitrile rubber NBR.

The friction (first operation and in working condition) is low thanks to the particular geometric shape of the seal.

Technical data

Pressure: from 0 to 400 Bar

Speed: 0.8 m/s

Temperature: from -30° C to +100° C

Fluids: mineral oils
(see table 3, page 14)

Material

The materials used for the construction of this type of seal are:

- polyurethane for the central element, hardness 93 Shore A, compound reference Co
- glass-filled polyacetal resin (POM) for the side elements.

Compound reference: CX

Assembling

This seal can be assembled both in closed groove on a mono-block piston and in open groove on a two-part piston.

Avoid machining scores on the piston which may damage the sealing during the installation.



KDSP

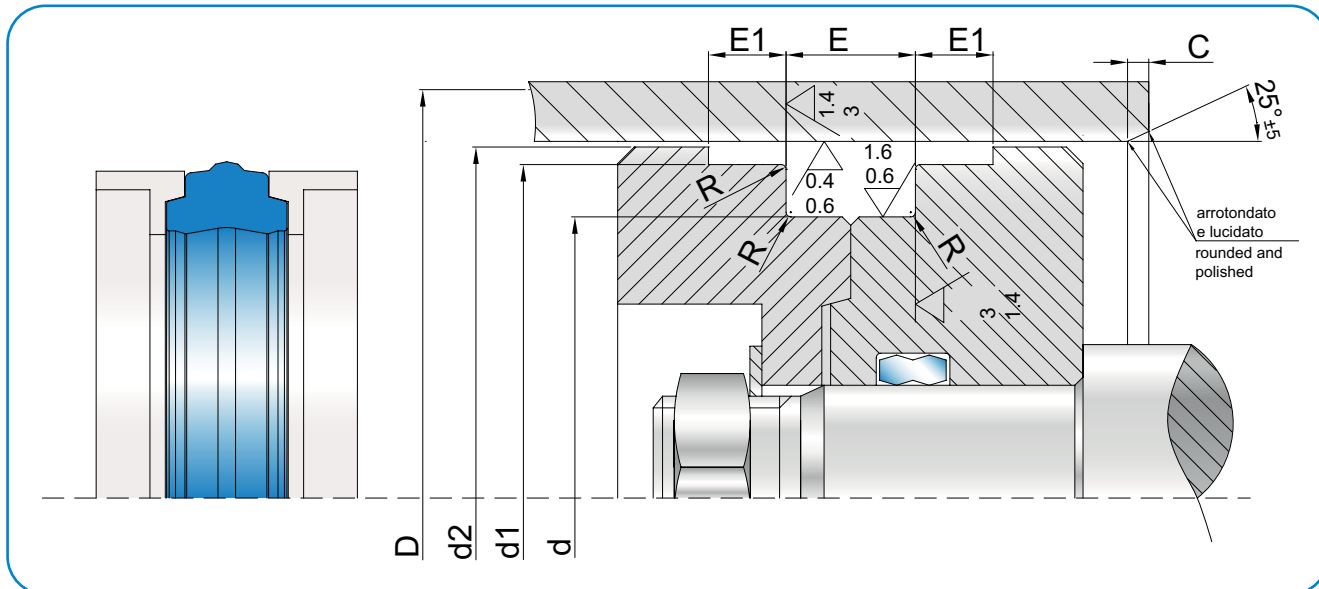
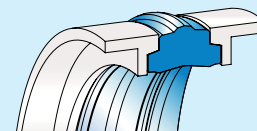

Oleodinamica
Hydraulic

	D _{H9}	d _{H9}	E _{+0,2}	d _{1H9}	d _{2±0,2}	E _{1 0/+0,1}	R	C	ART / ITEM
*	25,0	15,0	12,5	22,0	24,0	4,0	0,4	5,0	KDSP 0250 0150 125 CX
*	25,0	17,0	10,0	22,0	24,0	4,0	0,4	5,0	KDSP 0250 0170 100 CX
*	32,0	22,0	12,5	29,0	31,0	4,0	0,4	5,0	KDSP 0320 0220 125 CX
*	32,0	24,0	10,0	29,0	31,0	4,0	0,4	5,0	KDSP 0320 0240 100 CX
*	40,0	30,0	12,5	36,0	38,0	4,0	0,4	5,0	KDSP 0400 0300 125 CX
*	40,0	32,0	10,0	37,0	39,0	4,0	0,4	5,0	KDSP 0400 0320 100 CX
*	50,0	35,0	20,0	46,0	48,5	5,0	0,4	5,0	KDSP 0500 0350 200 CX
*	50,0	40,0	12,5	47,0	49,0	4,0	0,4	5,0	KDSP 0500 0400 125 CX
*	55,0	45,0	12,5	52,0	54,0	4,0	0,4	5,0	KDSP 0550 0450 125 CX
*	63,0	48,0	20,0	59,0	62,0	5,0	0,4	5,0	KDSP 0630 0480 200 CX
*	63,0	53,0	12,5	60,0	62,0	4,0	0,4	5,0	KDSP 0630 0530 125 CX
*	70,0	55,0	20,0	66,0	68,5	5,0	0,4	5,0	KDSP 0700 0550 200 CX
*	70,0	60,0	12,5	67,0	69,0	4,0	0,4	5,0	KDSP 0700 0600 125 CX
*	80,0	65,0	20,0	76,0	78,5	5,0	0,4	5,0	KDSP 0800 0650 200 CX
*	80,0	70,0	12,5	77,0	79,0	4,0	0,4	5,0	KDSP 0800 0700 125 CX
*	90,0	75,0	20,0	86,0	88,5	5,0	0,4	5,0	KDSP 0900 0750 200 CX
*	90,0	80,0	12,5	86,0	88,5	5,0	0,4	5,0	KDSP 0900 0800 125 CX
*	100,0	85,0	20,0	96,0	98,5	5,0	0,4	5,0	KDSP 1000 0850 200 CX
*	100,0	90,0	12,5	96,0	98,5	5,0	0,4	5,0	KDSP 1000 0900 125 CX

* ISO 6547

Nota: altre dimensioni non a catalogo a richiesta. Consultare il nostro ufficio tecnico.

Remark: please contact our technical dept. for further dimensions not included in the catalogue.

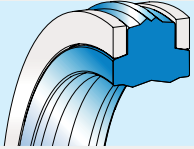

KDAE

TENUTA PISTONE COMPATTA TIPO KDAE

Descrizione

La tenuta pistone compatta KDAE nasce con un elemento centrale in poliuretano ad alto modulo elastico e due anelli antiestrusione laterali in elastomero con elevata durezza. Grazie alla combinazione dei due materiali, la tenuta rimane molto stabile anche alle alte pressioni. L'abrasione, con l'utilizzo del poliuretano, risulta di gran lunga inferiore a quella della gomma e accresce la durata del pistone stesso. L'attrito di primo distacco e in esercizio, grazie allo speciale profilo geometrico della tenuta, è più performante rispetto alla guarnizione in NBR.

Dati tecnici

Pressione: da 0 a 400 bar
 Velocità: < 0,8 m/s
 Temperatura: da -30° C a +100° C
 con punte fino a 110° C
 Fluidi: oli a base minerale
 (v. tabella 3 a p. 14)

Materiale

Il materiali utilizzati per la costruzione di questa tenuta sono:

- poliuretano di durezza 93 Shore A. Codice materiale tipo Co per l'elemento centrale
- poliacetalica caricata vetro (POM) per gli anelli antiestrusione laterali.

Codice materiale: CR

Montaggio

Il montaggio di questa tenuta è eseguibile sia in cava chiusa su pistone monoblocco sia in cava aperta su pistone in due pezzi (consigliato da Artic Seals). È importante che il pistone non presenti bave di lavorazione meccanica che danneggerebbero la tenuta durante il montaggio. È inoltre consigliato ingrassare il pistone per facilitare il montaggio.

KDAE TYPE COMPACT PISTON SEAL

Description

The KDAE compact piston seal series type is designed with a central polyurethane element and two side anti extrusion rings.

The assembling between the polyurethane element with high elastic modulus and the two elastomer rings with high hardness enhances stability of the sealing even at heavy duty applications.

Compared to rubber, the abrasion is also reduced due to the use of polyurethane, therefore extending the life of the seal.

The friction (first operation and in working condition) is also considerably reduced, due to geometric shape of the seal, having better performance than NBR.

Technical data

Pressure: from 0 to 400 bar
 Speed: < 0.8 m/s
 Temperature: from -30° C to +100 ° C with peaks
 up to +110° C
 Fluids: mineral oils
 (see table 3, page 14)

Material

The materials used for the construction of this type of seal are:

- polyurethane for the central element, hardness 93 Shore A (Co)
- glass-filled polyacetal resin (POM) for the antiextrusion rings.

Compound reference: CR

Assembling

This seal can be assembled both in closed groove on a mono-block piston and (Artic Seals suggestion) in open groove on a two-part piston.

Avoid machining scores on the piston which may damage the sealing during the installation.

The use of grease in the piston is recommended for easier assembling.



KDAE

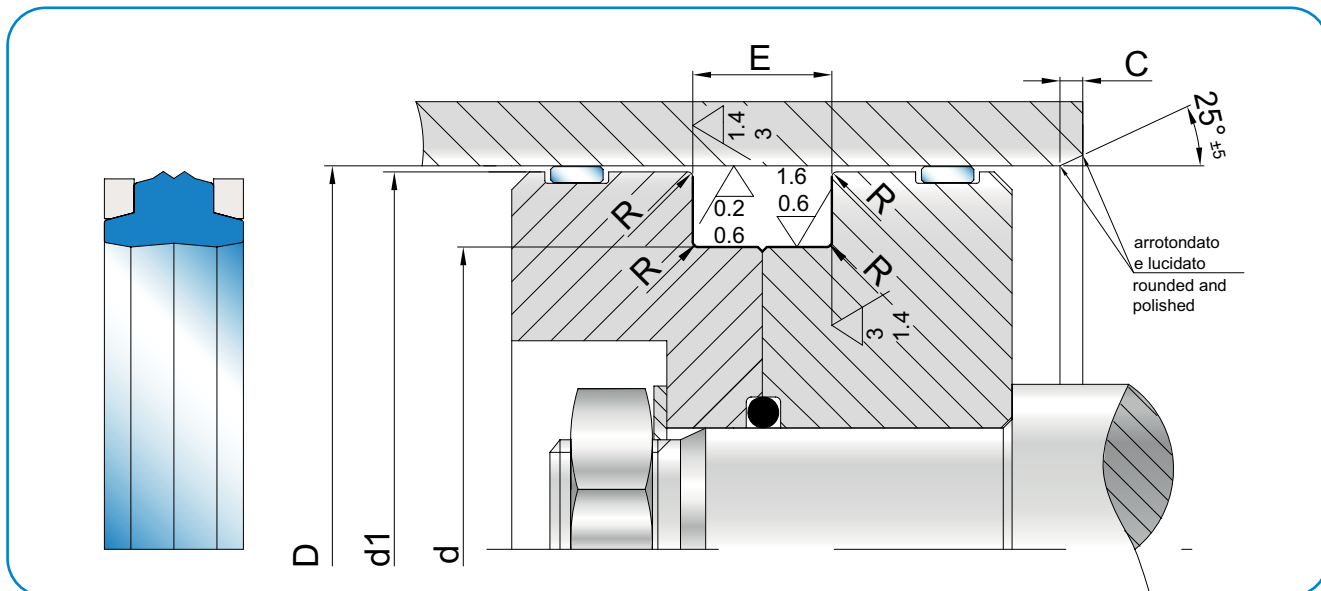
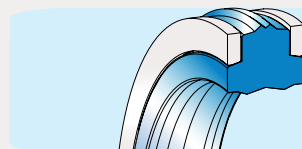

Oleodinamica
Hydraulic

D _{H9}	d _{h9}	E _{+0,2}	C	ART / ITEM
50,0	36,0	9,0	4,0	KDAE 0500 0360 090 CR
50,0	38,0	10,0	4,0	KDAE 0500 0380 100 CR
55,0	41,0	9,0	4,0	KDAE 0550 0410 090 CR
60,0	46,0	9,0	4,0	KDAE 0600 0460 090 CR
63,0	48,0	11,0	4,0	KDAE 0630 0480 110 CR
63,0	51,0	10,0	4,0	KDAE 0630 0510 100 CR
65,0	50,0	11,0	4,0	KDAE 0650 0500 110 CR
70,0	53,0	14,0	4,0	KDAE 0700 0530 140 CR
70,0	55,0	11,0	4,0	KDAE 0700 0550 110 CR
75,0	60,0	11,0	4,0	KDAE 0750 0600 110 CR
80,0	63,0	14,0	4,0	KDAE 0800 0630 140 CR
80,0	65,0	11,0	4,0	KDAE 0800 0650 110 CR
85,0	70,0	11,0	4,0	KDAE 0850 0700 110 CR
90,0	73,0	14,0	5,0	KDAE 0900 0730 140 CR
90,0	75,0	11,0	5,0	KDAE 0900 0750 110 CR

D _{H9}	d _{h9}	E _{+0,2}	C	ART / ITEM
95,0	80,0	11,0	5,0	KDAE 0950 0800 110 CR
100,0	83,0	14,0	5,0	KDAE 1000 0830 140 CR
100,0	85,0	12,5	5,0	KDAE 1000 0850 125 CR
105,0	88,0	14,0	5,0	KDAE 1050 0880 140 CR
105,0	90,0	12,5	5,0	KDAE 1050 0900 125 CR
110,0	93,0	14,0	5,0	KDAE 1100 0930 140 CR
110,0	95,0	12,5	5,0	KDAE 1100 0950 125 CR
115,0	98,0	14,0	5,0	KDAE 1150 0980 140 CR
115,0	100,0	12,5	5,0	KDAE 1150 1000 125 CR
120,0	103,0	14,0	5,0	KDAE 1200 1030 140 CR
120,0	105,0	12,5	5,0	KDAE 1200 1050 125 CR
125,0	108,0	14,0	5,0	KDAE 1250 1080 140 CR

Nota: altre dimensioni non a catalogo a richiesta. Consultare il nostro ufficio tecnico.

Remark: please contact our technical dept. for further dimensions not included in the catalogue.

Anelli guida

Wear rings

Materialie

In funzione delle specifiche esigenze determinate dal carico radiale del cilindro sono utilizzabili i seguenti materiali:

- resina poliacetalica (POM) vergine o rinforzata con fibra di vetro a basso coefficiente di attrito
- nylon (PA6 o PA66) caricato con varie tipologie di additivi tra cui vetro, PTFE e MoS₂
- polibutilentereftelato (PBT) caricato PTFE con proprietà autolubrificanti
- PTFE caricato bronzo (TM o TV) resistente all'usura e con basso attrito per applicazioni di basso-medio carico
- tessuto rinforzato con resina fenolica (FR) per sopportare elevati carichi radiali.

Material

The choice of the material depends on the specific needs arising from the cylinder radial load:

- polyacetal resin (POM) reinforced with fibreglass with low friction factor
- nylon (PA6 or PA66) different filled with: Glass, PTFE or MoS₂
- polibutilentereftelato (PBT) filled with PTFE, self-lubricating properties
- PTFE with bronze (TM or TV), wear resistant, low friction, for low and medium load
- fabrics reinforced phenolic (FR) resin, for high radial loads.

Tab.35 Dati Tecnici / Technical Data

Material	Velocità / Speed	Temperatura / Temperature	Carico Radiale / Radial Load	
	m/s	°C	N/ mm ²	T°
POM	<0,8	-40 to +115	<35 <25	<60 °C >60 °C
PA6 / PA66	<1,0	-40 to +140	<75 <40	<60 °C >60 °C
PBT	<1,0	-40 to +150	<35 <25	<60 °C >60 °C
PTFE	<15	-50 to +160 (200)	<15 <12 <8	30°C 80°C 120°C
Phenolic Resin	<1	-50 + 150	<120 <60	25°C 80°C



Dimensionamento

Utilizzando la seguente formula si possono calcolare le altezze delle guide come illustrato in fig.1

$$\text{Altezza Guida } T = \frac{C * f}{D * Cr}$$

Dove:

- C: carico radiale previsto in N [Newton]
- f: fattore di sicurezza [2]
- D: diametro stelo o camicia
- Cr: carico radiale ammissibile in N/mm² riferito al materiale.

Dimensioning

The following formula can be used to calculate the wear ring's height as shown in Pic.1

$$\text{Wear ring's height } T = \frac{C * f}{D * Cr}$$

As:

- C: radial load in N [Newton]
- f: safety factor [2]
- D: rod or bore diameter
- Cr: allowable radial load in N/mm reported material.

Fig.39: distribuzione del carico
Pic.39: load distribution

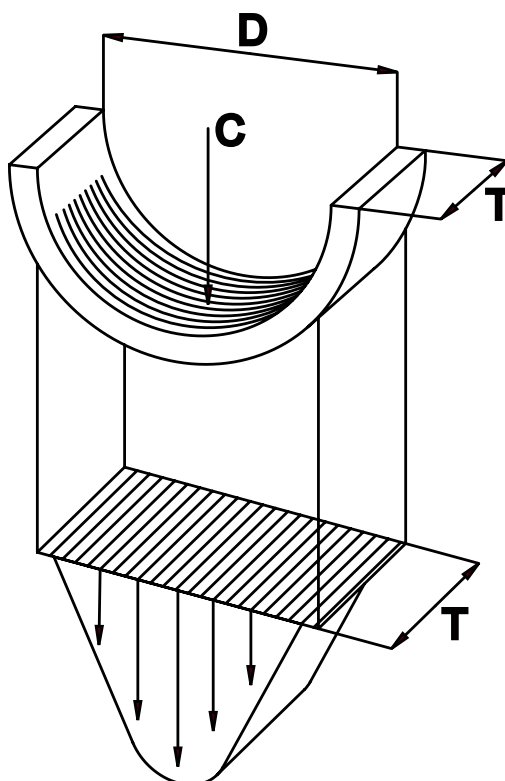

Nota: prego contattare il nostro ufficio tecnico per ulteriori informazioni.
Note: please contact our technical department for any further information.



Tab.36 Materiale Plastico / Plastics Material			
Sezione / Section		Altezza / Height	
D - d / 2 [mm]	S [mm]	E+0,2 [mm]	h [mm]
1,5	1,48 - 1,42	4	3,65 - 3,95
1,55	1,53 - 1,47	5,6	5,25 - 5,55
1,587	1,56 - 1,51	9,7	9,25 - 9,65
2	1,98 - 1,92	12,8	12,45 - 12,75
2,374	2,35 - 2,30	15	14,40 - 14,80
2,5	2,48 - 2,42	20	19,40 - 19,80
3	2,98 - 2,92	25	24,40 - 24,80
3,175	3,15 - 3,07	30	29,40 - 29,80

Tab.37 PTFE caricato / PTFE filled			
Sezione / Section		Altezza / Height	
D - d / 2 [mm]	S [mm]	E+0,2 [mm]	h [mm]
1,50	1,50 - 1,42	3,20	3,00 - 2,80
2,00	2,00 - 1,92	4,20	4,00 - 3,80
2,50	2,50 - 2,42	5,60	5,40 - 5,20
3,00	3,00 - 2,92	8,10	7,90 - 7,70
-	-	9,70	9,50 - 9,30
-	-	15,00	14,80 - 14,60
-	-	20,00	19,50 - 19,30
-	-	25,00	24,50 - 24,30
-	-	30,00	29,50 - 29,30
3,175	3,15 - 3,08	30	29,40 - 29,80

Tab.38 Resina Fenolica / Phenolic Resin			
Sezione / Section		Altezza / Height	
D - d / 2 [mm]	S [mm]	E+0,2 [mm]	h [mm]
2,50	2,50 - 2,45	5,60	5,50 - 5,30
D. <125[mm]		9,70	9,60 - 9,40
2,50	2,50 - 2,43	12,80	12,70 - 12,50
D. >125 [mm]		15,00	14,90 - 14,70
-	-	25,00	24,90 - 24,70



Tab.39 Physical and Mechanical properties of Engineered Plastics

Property	Unit	POM UV-stabiliser + 20%glass fiber	PA6 Heat stabilized + Glass Fiber (40%)	PBT + PTFE	Norms
Compressive strength	Mpa	36	207	47	ASTM D695 23°C
Tensile strength	Mpa	59	172		ASTM D638 23°C
Tensile modulus	Gpa	6,2	11,7	2,6	ASTM D638 23°C
Flexural strength	Mpa	74	269	79	ASTM D790 23°C
IZOD notched impact strength	J/m	43	133	38	ASTM D256 23°C
Water absorption (24 hours)	%	0,12	0,33	0,06	ASTM D570 23°C
Temperature Range	°C	-30 to +115	-40 to +140	-40 to +150	-
Rockwell Hardness	R scale	118	125	102	ASTM D785

Tab.40 Physical and Mechanical properties of PTFE Compound

Property	Unit	PTFE + Bronze (40%)	PTFE + Carbon (23%) + Graphite (2%)	Norms
Compressive strength	Mpa	64,8	24,8	ASTM D695 23°C
Tensile strength	Mpa	22,1	15,5	ASTM D1457-81A
Elongation	%	250	100	ASTM D4894
Deformation Under Load (24 h)	%	3,1	2,5	ASTM D621 @ 13,8 Mpa, 21°C
Coefficient of friction	-	0,23	0,24	ASTM D3702
Temperature Range	°C	-130 to +300	-215 to + 300°	-
Shore D Hardness	-	65	64	ASTMD2240-75

Tab.41 Physical and Mechanical properties of Phenolic resin compound

Property	Unit	Standard Polyester Based + PTFE	Polyester Based + Graphite	Polyester Based + MoS ₂	Polyester Based + PTFE	Norms
Compressive strength	Mpa	345	345	345	345	ASTM D695 23°C
Tensile strength	Mpa	75	75	75	75	ASTM D638 23°C
Tensile modulus	Mpa	3450	3450	3450	3450	ASTM D638 23°C
Coefficient of friction	-	0,13 - 0,20	0,15 - 0,20	0,15 - 0,20	0,13 - 0,20	ASTM D790 23°C
Water Absorption (24 hours)	%	0,1	0,1	0,1	0,1	ASTM D570 23°C
Temperature Range	°C	-40 to + 90	-40 to + 90	-40 to + 200	-40 to + 200	-
Rockwell M Hardness	-	100	100	100	100	ASTM D785

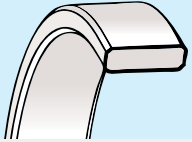

HIS

ANELLI GUIDA INTERNO TIPO HIS

Descrizione

I pattini di guida tipo HIS hanno la funzione di mantenere in asse tutto il sistema cilindro (stelo con testata e pistone con camicia) e svolgono due importanti compiti: aiutano la tenuta stelo, il raschiatore e la tenuta pistone a lavorare senza disallineamenti ed evitano il contatto tra le parti metalliche.

Il materiale, con un coefficiente di attrito molto basso, non crea perdite di carico (linearità) e sopporta deformazioni elevate sotto carico grazie al punto di rammollimento vicino al punto di fusione (lavora in esercizio a 115° C). Per facilitare la scelta della guida pistone o stelo e conoscerne l'altezza più idonea consigliamo la formula a p.139.

Dati tecnici

Velocità: < 0,8 m/s
 Temperatura: da - 40° C a + 115° C
 Fluidi: oli e fluidi a base minerale
 (v. tabella 3 a p. 14)

Materiale

Il materiale è una resina poliacetalica rinforzata con fibra di vetro.

Per temperature di esercizio superiori ai 115° C il materiale è una resina poliammidica rinforzata.

Codice materiale per temp < 115° C: Ro
 Codice materiale per temp > 115° C: R1

Montaggio

La guida tagliata e l'ottima elasticità semplificano il montaggio, mentre la presenza di smussi sui due lati facilita l'inserimento dello stelo.

Nota: sezione tecnica guide p.158

HIS TYPE INTERNAL WEAR RING

Description

The HIS wear rings have been developed in order to keep all the parts of the cylinder aligned (the rod with the head, the piston with the bore).

They play an important role as they help the rod seal, the wiper and the piston seal working without any misalignments and at the same time they prevent any contact between the metal parts. The material, which has a very low friction factor, does not cause load losses (linearity).

It endures deformations under heavy loads, as the softening point is close to the fusion point (it works at 115° C). For an easier choice of the piston or rod guide, we suggest the use of the formula at page 139 to find the wear ring length.

Technical data

Speed: < 0,8 m/s
 Temperature: from - 40° C to + 115° C
 Fluids: mineral oils and fluids
 (see table 3, page 14)

Material

The material is a polyacetal resin reinforced with fibreglass.

For working temperatures higher than 115° C, the material is a reinforced polyamide resin.

Compound reference for temp < 115° C: Ro
 Compound reference for temp > 115° C: R1

Assembling

The assembling can be easily done since the wear ring is cut and extremely elastic.

The chamfers on both sides have been studied to better insert the wear ring in the rod.

Note: wear rings technical section p.158



HIS

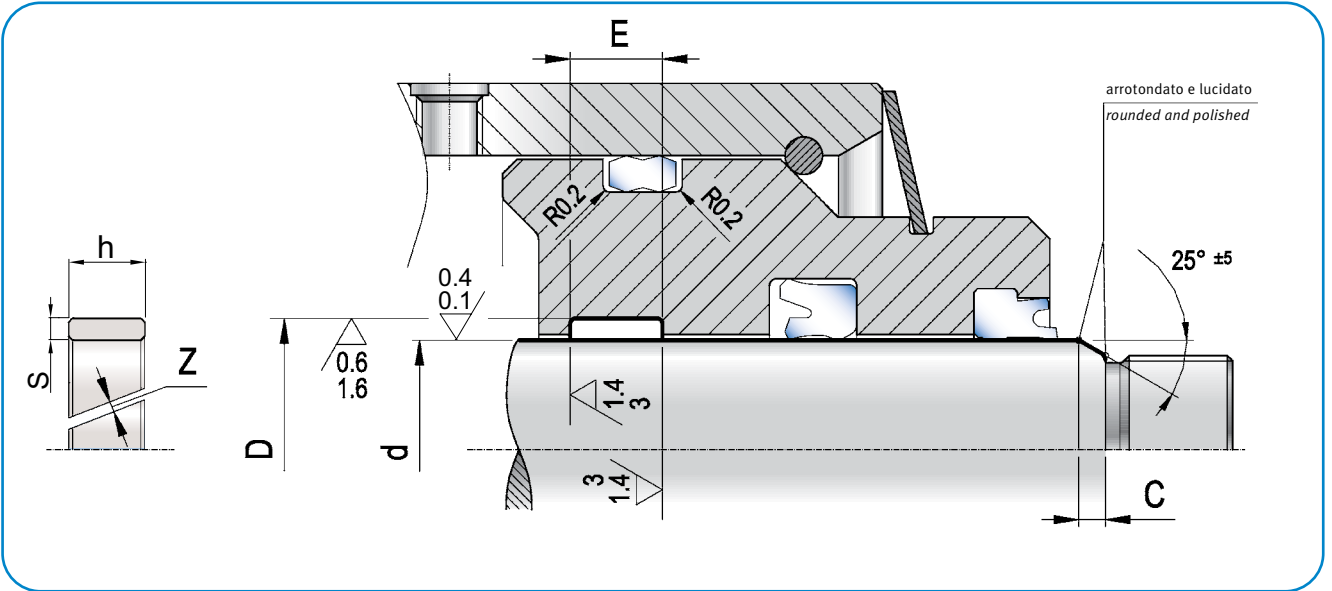
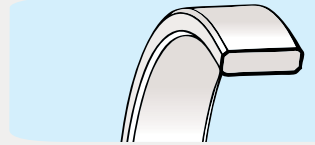

d_{h9}	$D_{-0, +0,05}$	$E_{+0,2}$	C	ART / ITEM
12,0	16,0	9,6	>3	HIS 0120 0160 096 Ro
14,0	18,0	9,6	>3	HIS 0140 0180 096 Ro
16,0	20,0	9,6	>3	HIS 0160 0200 096 Ro
18,0	22,0	9,6	>3	HIS 0180 0220 096 Ro
20,0	24,0	9,6	>3	HIS 0200 0240 096 Ro
20,0	25,0	5,6	>3	HIS 0200 0250 056 Ro
20,0	25,0	9,7	>3	HIS 0200 0250 097 Ro
22,0	26,0	9,6	>3	HIS 0220 0260 096 Ro
22,0	27,0	5,6	>3	HIS 0220 0270 056 Ro
22,0	27,0	9,7	>3	HIS 0220 0270 097 Ro
25,0	29,0	9,6	>3	HIS 0250 0290 096 Ro
25,0	30,0	5,6	>3	HIS 0250 0300 056 Ro
25,0	30,0	9,7	>3	HIS 0250 0300 097 Ro
26,0	30,0	9,6	>3	HIS 0260 0300 096 Ro
27,0	32,0	5,6	>3	HIS 0270 0320 056 Ro
27,0	32,0	9,7	>3	HIS 0270 0320 097 Ro
28,0	32,0	9,6	>3	HIS 0280 0320 096 Ro
28,0	33,0	5,6	>3	HIS 0280 0330 056 Ro
28,0	33,0	9,7	>3	HIS 0280 0330 097 Ro
30,0	34,0	9,6	>3	HIS 0300 0340 096 Ro
30,0	35,0	5,6	>3	HIS 0300 0350 056 Ro
30,0	35,0	9,7	>3	HIS 0300 0350 097 Ro
32,0	36,0	9,6	>3	HIS 0320 0360 096 Ro
32,0	37,0	5,6	>3	HIS 0320 0370 056 Ro

d_{h9}	$D_{-0, +0,05}$	$E_{+0,2}$	C	ART / ITEM
32,0	37,0	9,7	>3	HIS 0320 0370 097 Ro
35,0	39,0	9,6	>3	HIS 0350 0390 096 Ro
35,0	40,0	5,6	>3	HIS 0350 0400 056 Ro
35,0	40,0	9,7	>3	HIS 0350 0400 097 Ro
36,0	40,0	9,6	>3	HIS 0360 0400 096 Ro
36,0	41,0	5,6	>3	HIS 0360 0410 056 Ro
36,0	41,0	9,7	>3	HIS 0360 0410 097 Ro
38,0	42,0	9,6	>3	HIS 0380 0420 096 Ro
40,0	44,0	9,6	>3	HIS 0400 0440 096 Ro
40,0	45,0	5,6	>3	HIS 0400 0450 056 Ro
40,0	45,0	9,7	>3	HIS 0400 0450 097 Ro
40,0	45,0	15,0	>3	HIS 0400 0450 150 Ro
42,0	46,0	9,6	>3	HIS 0420 0460 096 Ro
42,0	48,0	9,6	>3	HIS 0420 0480 096 Ro
43,0	48,0	5,6	>3	HIS 0430 0480 056 Ro
45,0	50,0	5,6	>3	HIS 0450 0500 056 Ro
45,0	50,0	9,7	>3	HIS 0450 0500 097 Ro
45,0	50,0	15,0	>3	HIS 0450 0500 150 Ro
45,0	51,0	9,6	>3	HIS 0450 0510 096 Ro
46,0	52,0	9,6	>3	HIS 0460 0520 096 Ro
47,0	52,0	5,6	>3	HIS 0470 0520 056 Ro
47,0	52,0	9,7	>3	HIS 0470 0520 097 Ro
48,0	54,0	9,6	>3	HIS 0480 0540 096 Ro
50,0	55,0	5,6	>3	HIS 0500 0550 056 Ro

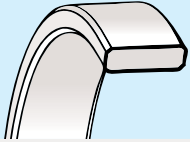

HIS

d _{h9}	D ⁻⁰ _{+0,05}	E _{+0,2}	C	ART / ITEM
50,0	55,0	9,7	> 3	HIS 0500 0550 097 Ro
50,0	55,0	15,0	> 3	HIS 0500 0550 150 Ro
50,0	56,0	9,6	> 3	HIS 0500 0560 096 Ro
52,0	57,0	9,7	> 3	HIS 0520 0570 097 Ro
55,0	60,0	5,6	> 3	HIS 0550 0600 056 Ro
55,0	60,0	9,7	> 3	HIS 0550 0600 097 Ro
55,0	60,0	15,0	> 3	HIS 0550 0600 150 Ro
55,0	61,0	9,6	> 3	HIS 0550 0610 096 Ro
56,0	61,0	5,6	> 3	HIS 0560 0610 056 Ro
56,0	61,0	9,7	> 3	HIS 0560 0610 097 Ro
56,0	62,0	12,8	> 3	HIS 0560 0620 128 Ro
58,0	63,0	5,6	> 3	HIS 0580 0630 056 Ro
58,0	63,0	9,7	> 3	HIS 0580 0630 097 Ro
60,0	65,0	5,6	> 3	HIS 0600 0650 056 Ro
60,0	65,0	9,7	> 3	HIS 0600 0650 097 Ro
60,0	65,0	15,0	> 3	HIS 0600 0650 150 Ro
60,0	66,0	12,8	> 3	HIS 0600 0660 128 Ro
63,0	68,0	5,6	> 3	HIS 0630 0680 056 Ro
63,0	68,0	9,7	> 3	HIS 0630 0680 097 Ro
63,0	69,0	12,8	> 3	HIS 0630 0690 128 Ro
65,0	70,0	5,6	> 3	HIS 0650 0700 056 Ro
65,0	70,0	9,7	> 3	HIS 0650 0700 097 Ro
65,0	70,0	15,0	> 3	HIS 0650 0700 150 Ro
65,0	71,0	12,8	> 3	HIS 0650 0710 128 Ro
67,0	72,0	5,6	> 3	HIS 0670 0720 056 Ro
70,0	75,0	5,6	> 3	HIS 0700 0750 056 Ro
70,0	75,0	9,7	> 3	HIS 0700 0750 097 Ro
70,0	75,0	15,0	> 3	HIS 0700 0750 150 Ro
70,0	76,0	30,0	> 3	HIS 0700 0760 300 Ro
70,0	76,0	12,8	> 3	HIS 0700 0760 128 Ro
72,0	78,0	12,8	> 3	HIS 0720 0780 128 Ro
75,0	80,0	5,6	> 4	HIS 0750 0800 056 Ro
75,0	80,0	9,7	> 4	HIS 0750 0800 097 Ro
75,0	80,0	15,0	> 4	HIS 0750 0800 150 Ro
75,0	81,0	12,8	> 4	HIS 0750 0810 128 Ro
76,0	82,0	12,8	> 4	HIS 0760 0820 128 Ro
80,0	85,0	5,6	> 4	HIS 0800 0850 056 Ro
80,0	85,0	9,7	> 4	HIS 0800 0850 097 Ro
80,0	85,0	15,0	> 4	HIS 0800 0850 150 Ro
80,0	86,0	12,8	> 4	HIS 0800 0860 128 Ro
85,0	90,0	5,6	> 4	HIS 0850 0900 056 Ro
85,0	90,0	9,7	> 4	HIS 0850 0900 097 Ro
85,0	90,0	15,0	> 4	HIS 0850 0900 150 Ro
85,0	91,0	12,8	> 4	HIS 0850 0910 128 Ro
90,0	95,0	5,6	> 4	HIS 0900 0950 056 Ro

d _{h9}	D ⁻⁰ _{+0,05}	E _{+0,2}	C	ART / ITEM
90,0	95,0	9,7	> 4	HIS 0900 0950 097 Ro
90,0	95,0	15,0	> 4	HIS 0900 0950 150 Ro
90,0	96,0	12,8	> 4	HIS 0900 0960 128 Ro
92,0	97,0	5,6	> 4	HIS 0920 0970 056 Ro
95,0	100,0	5,6	> 4	HIS 0950 1000 056 Ro
95,0	100,0	9,7	> 4	HIS 0950 1000 097 Ro
95,0	100,0	15,0	> 4	HIS 0950 1000 150 Ro
95,0	100,0	20,0	> 4	HIS 0950 1000 200 Ro
95,0	100,0	25,0	> 4	HIS 0950 1000 250 Ro
95,0	101,0	12,8	> 4	HIS 0950 1010 128 Ro
100,0	105,0	5,6	> 4	HIS 1000 1050 056 Ro
100,0	105,0	9,7	> 4	HIS 1000 1050 097 Ro
100,0	105,0	15,0	> 4	HIS 1000 1050 150 Ro
100,0	105,0	20,0	> 4	HIS 1000 1050 200 Ro
100,0	105,0	25,0	> 4	HIS 1000 1050 250 Ro
100,0	106,0	12,8	> 4	HIS 1000 1060 128 Ro
105,0	110,0	9,7	> 4	HIS 1050 1100 097 Ro
105,0	110,0	15,0	> 4	HIS 1050 1100 150 Ro
105,0	110,0	20,0	> 4	HIS 1050 1100 200 Ro
105,0	110,0	25,0	> 4	HIS 1050 1100 250 Ro
105,0	111,0	12,8	> 4	HIS 1050 1110 128 Ro
110,0	115,0	9,7	> 4	HIS 1100 1150 097 Ro
110,0	115,0	15,0	> 4	HIS 1100 1150 150 Ro
110,0	115,0	20,0	> 4	HIS 1100 1150 200 Ro
110,0	115,0	25,0	> 4	HIS 1100 1150 250 Ro
110,0	116,0	12,8	> 4	HIS 1100 1160 128 Ro
115,0	120,0	9,7	> 4	HIS 1150 1200 097 Ro
115,0	120,0	15,0	> 4	HIS 1150 1200 150 Ro
115,0	120,0	20,0	> 4	HIS 1150 1200 200 Ro
115,0	120,0	25,0	> 4	HIS 1150 1200 250 Ro
115,0	121,0	12,8	> 4	HIS 1150 1210 128 Ro
120,0	125,0	9,7	> 4	HIS 1200 1250 097 Ro
120,0	125,0	15,0	> 4	HIS 1200 1250 150 Ro
120,0	125,0	20,0	> 4	HIS 1200 1250 200 Ro
120,0	125,0	25,0	> 4	HIS 1200 1250 250 Ro
120,0	126,0	12,8	> 4	HIS 1200 1260 128 Ro
125,0	130,0	9,7	> 4	HIS 1250 1300 097 Ro
125,0	130,0	15,0	> 4	HIS 1250 1300 150 Ro
125,0	130,0	20,0	> 4	HIS 1250 1300 200 Ro
125,0	130,0	25,0	> 4	HIS 1250 1300 250 Ro
125,0	131,0	12,8	> 4	HIS 1250 1310 128 Ro
130,0	135,0	15,0	> 4	HIS 1300 1350 150 Ro
130,0	135,0	20,0	> 4	HIS 1300 1350 200 Ro
130,0	135,0	25,0	> 4	HIS 1300 1350 250 Ro
130,0	136,0	12,8	> 4	HIS 1300 1360 128 Ro



HIS

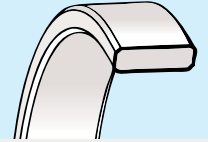

d_{hg}	$D_{-0, +0,05}$	$E_{+0,2}$	C	ART / ITEM
135,0	140,0	15,0	> 4	HIS 1350 1400 150 Ro
135,0	140,0	20,0	> 4	HIS 1350 1400 200 Ro
135,0	140,0	25,0	> 4	HIS 1350 1400 250 Ro
135,0	141,0	12,8	> 4	HIS 1350 1410 128 Ro
140,0	145,0	15,0	> 4	HIS 1400 1450 150 Ro
140,0	145,0	20,0	> 4	HIS 1400 1450 200 Ro
140,0	145,0	25,0	> 4	HIS 1400 1450 250 Ro
140,0	146,0	12,8	> 4	HIS 1400 1460 128 Ro
145,0	150,0	9,7	> 4	HIS 1450 1500 097 Ro
145,0	150,0	15,0	> 4	HIS 1450 1500 150 Ro
145,0	150,0	20,0	> 4	HIS 1450 1500 200 Ro
145,0	150,0	25,0	> 4	HIS 1450 1500 250 Ro
145,0	151,0	12,8	> 4	HIS 1450 1510 128 Ro
150,0	155,0	15,0	> 4	HIS 1500 1550 150 Ro
150,0	156,0	12,8	> 4	HIS 1500 1560 128 Ro
155,0	161,0	19,2	> 4	HIS 1550 1610 192 Ro
160,0	166,0	19,2	> 5	HIS 1600 1660 192 Ro
165,0	171,0	19,2	> 5	HIS 1650 1710 192 Ro

d_{hg}	$D_{-0, +0,05}$	$E_{+0,2}$	C	ART / ITEM
170,0	176,0	19,2	> 5	HIS 1700 1760 192 Ro
175,0	181,0	19,2	> 5	HIS 1750 1810 192 Ro
180,0	186,0	19,2	> 5	HIS 1800 1860 192 Ro
185,0	191,0	19,2	> 5	HIS 1850 1910 192 Ro
190,0	196,0	19,2	> 5	HIS 1900 1960 192 Ro
195,0	201,0	19,2	> 5	HIS 1950 2100 192 Ro
200,0	206,0	19,2	> 5	HIS 2000 2060 192 Ro
205,0	211,0	19,2	> 5	HIS 2050 2110 192 Ro
210,0	216,0	19,2	> 5	HIS 2100 2160 192 Ro
215,0	221,0	19,2	> 5	HIS 2150 2210 192 Ro
220,0	226,0	19,2	> 5	HIS 2200 2260 192 Ro
225,0	231,0	19,2	> 5	HIS 2250 2310 192 Ro
230,0	236,0	19,2	> 5	HIS 2300 2360 192 Ro
235,0	241,0	19,2	> 5	HIS 2350 2410 192 Ro
240,0	246,0	19,2	> 5	HIS 2400 2460 192 Ro
245,0	251,0	19,2	> 5	HIS 2450 2510 192 Ro

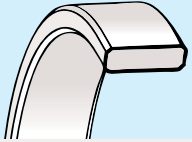

HES

ANELLI GUIDA ESTERNO TIPO HES

Descrizione

I pattini di guida tipo HES hanno la funzione di mantenere in asse tutto il sistema cilindro (stelo con testata e pistone con camicia) e svolgono due importanti compiti: aiutano la tenuta stelo, il raschiatore e la tenuta pistone a lavorare senza disallineamenti ed evitano il contatto tra le parti metalliche. Il materiale, con un coefficiente di attrito molto basso, non crea perdite di carico (linearità) e sopporta deformazioni elevate sotto carico grazie al punto di rammollimento vicino al punto di fusione (lavora in esercizio a 115° C). Per facilitare la scelta della guida pistone o stelo e conoscerne l'altezza più idonea consigliamo la formula a p.139.

Dati tecnici

Velocità: < 0,8 m/s
 Temperatura: da - 40° C a + 115° C
 Fluidi: oli e fluidi a base minerale
 (v. tabella 3 a p. 14)

Materiale

Il materiale è una resina poliacetalica rinforzata con fibra di vetro. Per temperature di esercizio superiori ai 115° C il materiale è una resina poliammidica rinforzata. Codice materiale per temp < 115°C: Ro
 Codice materiale per temp > 115°C: R1

Montaggio

La guida tagliata e l'ottima elasticità semplificano il montaggio, mentre la presenza di smussi sui due lati facilita l'inserimento del pistone.

Nota: sezione tecnica guide p.158

HES TYPE EXTERNAL WEAR RING

Description

The HES wear rings have been developed in order to keep all the parts of the cylinder aligned (the rod with the head, the piston with the bore). They play an important role as they help the rod seal, the wiper and the piston seal working without any misalignments and at the same time they prevent any contact between the metal parts. The material, which has a very low friction factor, does not cause load losses (linearity). It endures deformations under heavy loads, as the softening point is close to the fusion point (it works at 115° C). For an easier choice of the piston or rod guide, we suggest the use of the formula at page 139 to find the wear ring length.

Technical data

Speed: < 0,8 m/s
 Temperature: from - 40° C to + 115° C
 Fluids: mineral oils and fluids
 (see table 3, page 14)

Material

The material is a polyacetalic resin reinforced with fibreglass. For working temperatures higher than 115° C, the material is a reinforced polyamide resin. Compound reference for temp < 115°C: Ro
 Compound reference for temp > 115°C: R1

Assembling

The assembling can be easily done since the wear ring is cut and extremely elastic. The chamfers on both sides have been studied to better insert the wear ring in the rod.

Note: wear rings technical section p.158



HES

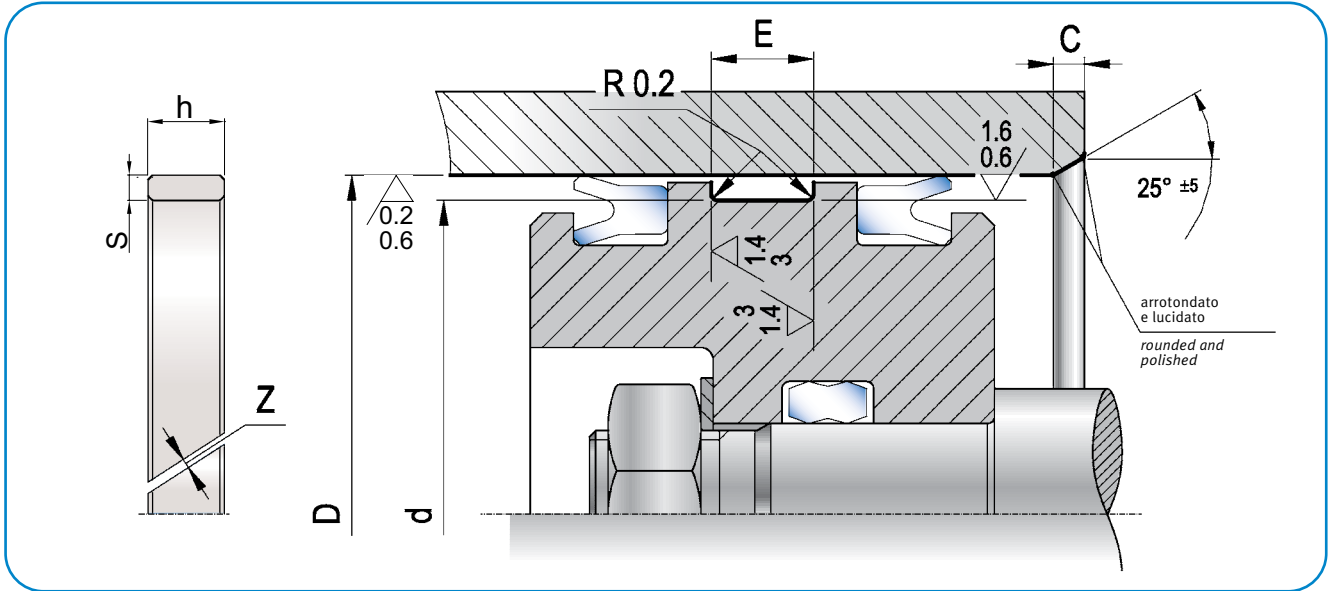
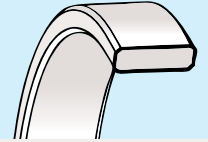

D _{H9}	d ₊₀ -0,05	E _{+0,2}	C	ART / ITEM
16,0	12,0	9,6	>3	HES 0160 0120 096 Ro
18,0	14,0	9,6	>3	HES 0180 0140 096 Ro
20,0	16,0	9,6	>3	HES 0200 0160 096 Ro
22,0	18,0	9,6	>3	HES 0220 0180 096 Ro
24,0	20,0	9,6	>3	HES 0240 0200 096 Ro
25,0	20,0	5,6	>3	HES 0250 0200 056 Ro
25,0	20,0	9,7	>3	HES 0250 0200 097 Ro
25,0	21,0	9,6	>3	HES 0250 0210 096 Ro
27,0	22,0	5,6	>3	HES 0270 0220 056 Ro
27,0	22,0	9,7	>3	HES 0270 0220 097 Ro
28,0	24,0	9,6	>3	HES 0280 0240 096 Ro
30,0	25,0	5,6	>3	HES 0300 0250 056 Ro
30,0	25,0	9,7	>3	HES 0300 0250 097 Ro
30,0	26,0	9,6	>3	HES 0300 0260 096 Ro
32,0	27,0	5,6	>3	HES 0320 0270 056 Ro
32,0	27,0	9,7	>3	HES 0320 0270 097 Ro
32,0	28,0	9,6	>3	HES 0320 0280 096 Ro
33,0	28,0	5,6	>3	HES 0330 0280 056 Ro
33,0	28,0	9,7	>3	HES 0330 0280 097 Ro
34,0	30,0	9,6	>3	HES 0340 0300 096 Ro
35,0	30,0	5,6	>3	HES 0350 0300 056 Ro
35,0	30,0	9,7	>3	HES 0350 0300 097 Ro
35,0	31,0	9,6	>3	HES 0350 0310 096 Ro
36,0	32,0	9,6	>3	HES 0360 0320 096 Ro

D _{H9}	d ₊₀ -0,05	E _{+0,2}	C	ART / ITEM
37,0	32,0	5,6	>3	HES 0370 0320 056 Ro
37,0	32,0	9,7	>3	HES 0370 0320 097 Ro
38,1	35,1	2,5	>3	HES 0381 0351 025 Ro
40,0	35,0	5,6	>3	HES 0400 0350 056 Ro
40,0	35,0	9,7	>3	HES 0400 0350 097 Ro
40,0	36,0	9,6	>3	HES 0400 0360 096 Ro
40,0	37,0	2,5	>3	HES 0400 0370 025 Ro
41,0	36,0	5,6	>3	HES 0410 0360 056 Ro
41,0	36,0	9,7	>3	HES 0410 0360 097 Ro
44,4	41,4	2,5	>3	HES 0444 0414 025 Ro
45,0	40,0	5,6	>3	HES 0450 0400 056 Ro
45,0	40,0	9,7	>3	HES 0450 0400 097 Ro
45,0	40,0	15,0	>3	HES 0450 0400 150 Ro
45,0	41,0	9,6	>3	HES 0450 0410 096 Ro
48,0	43,0	5,6	>3	HES 0480 0430 056 Ro
50,0	44,0	9,6	>3	HES 0500 0440 096 Ro
50,0	45,0	5,6	>3	HES 0500 0450 056 Ro
50,0	45,0	9,7	>3	HES 0500 0450 097 Ro
50,0	45,0	15,0	>3	HES 0500 0450 150 Ro
50,8	47,8	2,5	>3	HES 0508 0478 025 Ro
52,0	47,0	5,6	>3	HES 0520 0470 056 Ro
52,0	47,0	9,7	>3	HES 0520 0470 097 Ro
55,0	49,0	12,8	>3	HES 0550 0490 128 Ro
55,0	50,0	5,6	>3	HES 0550 0500 056 Ro

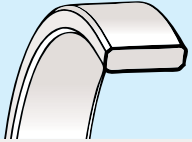

HES

D H ₉	d ₊₀ _{-0,05}	E _{+0,2}	C	ART / ITEM
55,0	50,0	9,7	> 3	HES 0550 0500 097 Ro
55,0	50,0	15,0	> 3	HES 0550 0500 150 Ro
60,0	54,0	12,8	> 3	HES 0600 0540 128 Ro
60,0	55,0	5,6	> 3	HES 0600 0550 056 Ro
60,0	55,0	9,7	> 3	HES 0600 0550 097 Ro
60,0	55,0	15,0	> 3	HES 0600 0550 150 Ro
61,0	56,0	5,6	> 3	HES 0610 0560 056 Ro
61,0	56,0	9,7	> 3	HES 0610 0560 097 Ro
63,0	57,0	12,8	> 3	HES 0630 0570 128 Ro
63,0	58,0	5,6	> 3	HES 0630 0580 056 Ro
63,0	58,0	9,7	> 3	HES 0630 0580 097 Ro
63,5	60,5	2,5	> 3	HES 0635 0605 025 Ro
65,0	59,0	12,8	> 3	HES 0650 0590 128 Ro
65,0	60,0	5,6	> 3	HES 0650 0600 056 Ro
65,0	60,0	9,7	> 3	HES 0650 0600 097 Ro
65,0	60,0	15,0	> 3	HES 0650 0600 150 Ro
68,0	63,0	5,6	> 3	HES 0680 0630 056 Ro
68,0	63,0	9,7	> 3	HES 0680 0630 097 Ro
70,0	64,0	12,8	> 3	HES 0700 0640 128 Ro
70,0	65,0	5,6	> 3	HES 0700 0650 056 Ro
70,0	65,0	9,7	> 3	HES 0700 0650 097 Ro
70,0	65,0	15,0	> 3	HES 0700 0650 150 Ro
70,0	60,0	10,0	> 3	HES 0700 0660 100 Ro
72,0	67,0	5,6	> 3	HES 0720 0670 056 Ro
75,0	69,0	12,8	> 3	HES 0750 0690 128 Ro
75,0	70,0	5,6	> 3	HES 0750 0700 056 Ro
75,0	70,0	9,7	> 3	HES 0750 0700 097 Ro
75,0	70,0	15,0	> 3	HES 0750 0700 150 Ro
80,0	74,0	12,8	> 4	HES 0800 0740 128 Ro
80,0	75,0	5,6	> 4	HES 0800 0750 056 Ro
80,0	75,0	9,7	> 4	HES 0800 0750 097 Ro
80,0	75,0	15,0	> 4	HES 0800 0750 150 Ro
85,0	79,0	12,8	> 4	HES 0850 0790 128 Ro
85,0	80,0	5,6	> 4	HES 0850 0800 056 Ro
85,0	80,0	9,7	> 4	HES 0850 0800 097 Ro
85,0	80,0	15,0	> 4	HES 0850 0800 150 Ro
90,0	84,0	12,8	> 4	HES 0900 0840 128 Ro
90,0	85,0	5,6	> 4	HES 0900 0850 056 Ro
90,0	85,0	9,7	> 4	HES 0900 0850 097 Ro
90,0	85,0	15,0	> 4	HES 0900 0850 150 Ro
95,0	89,0	12,8	> 4	HES 0950 0890 128 Ro
95,0	90,0	5,6	> 4	HES 0950 0900 056 Ro
95,0	90,0	9,7	> 4	HES 0950 0900 097 Ro
95,0	90,0	15,0	> 4	HES 0950 0900 150 Ro
97,0	92,0	5,6	> 4	HES 0970 0920 056 Ro

D H ₉	d ₊₀ _{-0,05}	E _{+0,2}	C	ART / ITEM
100,0	94,0	12,8	> 4	HES 1000 0940 128 Ro
100,0	95,0	5,6	> 4	HES 1000 0950 056 Ro
100,0	95,0	9,7	> 4	HES 1000 0950 097 Ro
100,0	95,0	15,0	> 4	HES 1000 0950 150 Ro
100,0	95,0	20,0	> 4	HES 1000 0950 200 Ro
100,0	95,0	25,0	> 4	HES 1000 0950 250 Ro
105,0	99,0	12,8	> 4	HES 1050 0990 128 Ro
105,0	100,0	5,6	> 4	HES 1050 1000 056 Ro
105,0	100,0	9,7	> 4	HES 1050 1000 097 Ro
105,0	100,0	15,0	> 4	HES 1050 1000 150 Ro
105,0	100,0	20,0	> 4	HES 1050 1000 200 Ro
105,0	100,0	25,0	> 4	HES 1050 1000 250 Ro
110,0	104,0	12,8	> 4	HES 1100 1040 128 Ro
110,0	105,0	9,7	> 4	HES 1100 1050 097 Ro
110,0	105,0	15,0	> 4	HES 1100 1050 150 Ro
110,0	105,0	20,0	> 4	HES 1100 1050 200 Ro
110,0	105,0	25,0	> 4	HES 1100 1050 250 Ro
115,0	109,0	12,8	> 4	HES 1150 1090 128 Ro
115,0	110,0	9,7	> 4	HES 1150 1100 097 Ro
115,0	110,0	15,0	> 4	HES 1150 1100 150 Ro
115,0	110,0	20,0	> 4	HES 1150 1100 200 Ro
115,0	110,0	25,0	> 4	HES 1150 1100 250 Ro
120,0	114,0	12,8	> 4	HES 1200 1140 128 Ro
120,0	115,0	9,7	> 4	HES 1200 1150 097 Ro
120,0	115,0	15,0	> 4	HES 1200 1150 150 Ro
120,0	115,0	20,0	> 4	HES 1200 1150 200 Ro
120,0	115,0	25,0	> 4	HES 1200 1150 250 Ro
125,0	119,0	12,8	> 4	HES 1250 1190 128 Ro
125,0	120,0	9,7	> 4	HES 1250 1200 097 Ro
125,0	120,0	15,0	> 4	HES 1250 1200 150 Ro
125,0	120,0	20,0	> 4	HES 1250 1200 200 Ro
125,0	120,0	25,0	> 4	HES 1250 1200 250 Ro
130,0	124,0	12,8	> 4	HES 1300 1240 128 Ro
130,0	125,0	15,0	> 4	HES 1300 1250 150 Ro
130,0	125,0	20,0	> 4	HES 1300 1250 200 Ro
130,0	125,0	25,0	> 4	HES 1300 1250 250 Ro
135,0	129,0	12,8	> 4	HES 1350 1290 128 Ro
135,0	130,0	15,0	> 4	HES 1350 1300 150 Ro
135,0	130,0	20,0	> 4	HES 1350 1300 200 Ro
135,0	130,0	25,0	> 4	HES 1350 1300 250 Ro
140,0	134,0	12,8	> 4	HES 1400 1340 128 Ro
140,0	135,0	15,0	> 4	HES 1400 1350 150 Ro
140,0	135,0	20,0	> 4	HES 1400 1350 200 Ro
140,0	135,0	25,0	> 4	HES 1400 1350 250 Ro
145,0	139,0	12,8	> 4	HES 1450 1390 128 Ro



HES

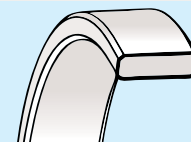

D _{H9}	d ₊₀ -0,05	E _{+0,2}	C	ART / ITEM
145,0	140,0	15,0	> 4	HES 1450 1400 150 Ro
145,0	140,0	20,0	> 4	HES 1450 1400 200 Ro
145,0	140,0	25,0	> 4	HES 1450 1400 250 Ro
150,0	144,0	12,8	> 4	HES 1500 1440 128 Ro
150,0	145,0	15,0	> 4	HES 1500 1450 150 Ro
150,0	145,0	20,0	> 4	HES 1500 1450 200 Ro
150,0	145,0	25,0	> 4	HES 1500 1450 250 Ro
155,0	149,0	19,2	> 4	HES 1550 1490 192 Ro
160,0	154,0	19,2	> 5	HES 1600 1540 192 Ro
160,0	155,0	15,0	> 5	HES 1600 1550 150 Ro
165,0	159,0	19,2	> 5	HES 1650 1590 192 Ro
170,0	164,0	19,2	> 5	HES 1700 1640 192 Ro
175,0	169,0	19,2	> 5	HES 1750 1690 192 Ro
180,0	174,0	19,2	> 5	HES 1800 1740 192 Ro
185,0	179,0	19,2	> 5	HES 1850 1790 192 Ro

D _{H9}	d ₊₀ -0,05	E _{+0,2}	C	ART / ITEM
190,0	184,0	19,2	> 5	HES 1900 1840 192 Ro
195,0	189,0	19,2	> 5	HES 1950 1890 192 Ro
200,0	194,0	19,2	> 5	HES 2000 1940 192 Ro
210,0	204,0	19,2	> 5	HES 2100 2040 192 Ro
220,0	214,0	19,2	> 5	HES 2200 2140 192 Ro
230,0	224,0	19,2	> 5	HES 2300 2240 192 Ro
240,0	234,0	19,2	> 5	HES 2400 2340 192 Ro
250,0	244,0	19,2	> 5	HES 2500 2440 192 Ro

Nota: altre dimensioni non a catalogo a richiesta. Consultare il nostro ufficio tecnico.

Remark: please contact our technical dept. for further dimensions not included in the catalogue.

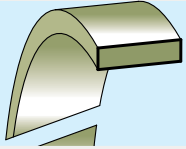

NG

NASTRO GUIDA IN PTFE TIPO NG

Descrizione

Il nastro guida NG in politetrafluoroetilene caricato bronzo è fornito in rotoli dai quali si ricavano guide intercambiabili con quelle in materiale termoplastico. Le guide sono progettate sia per stelo sia per pistone e hanno come caratteristiche principali la precisione dello spessore e la quasi assenza di attrito. Per la loro inerzia chimica sono compatibili con molti fluidi. Possono essere con o senza smussi di invito.

Dati Tecnici

Velocità: < 15 m/s

Temperatura: da -50°C a +160°C con punte a 200°C

Fluidi: molti fluidi essendo un materiale con inerzia chimica elevata
(v. tabella 3 a p. 14)

Materiale

Il materiale è politetrafluoroetilene (PTFE) con cariche interne di bronzo.

Codice materiale:

TV LBR4030 (verde)

TM LBR4003 (grigio/ marrone)

Montaggio

La guida tagliata e l'ottima elasticità semplificano il montaggio.

Nota: sezione tecnica guide p.158

NG TYPE PTFE WEAR TAPE

Description

NG bronze filled PTFE tape is supplied in rolls.

By cutting them is possible to obtain interchangeable guides to replace thermoplastic material.

They can be used for rods or pistons.

Thanks to the properties (thickness accuracy, low friction and chemical resistance) are compatible with many fluids.

They can be with or without chamfers.

Technical Data

Speed: < 15 m/s

Temperature: from -50°C to +160°C peaks till 200°C.

Fluidi: many fluids as a material with high chemical inertia
(see table 3, page 14)

Material

The material is bronze filled PTFE.

Compound reference:

TV LBR4030 (green)

TM LBR4003 (dark brown)

Assembling

The assembling can be easily done since the wear ring is cut.

Note: wear rings technical section p.158

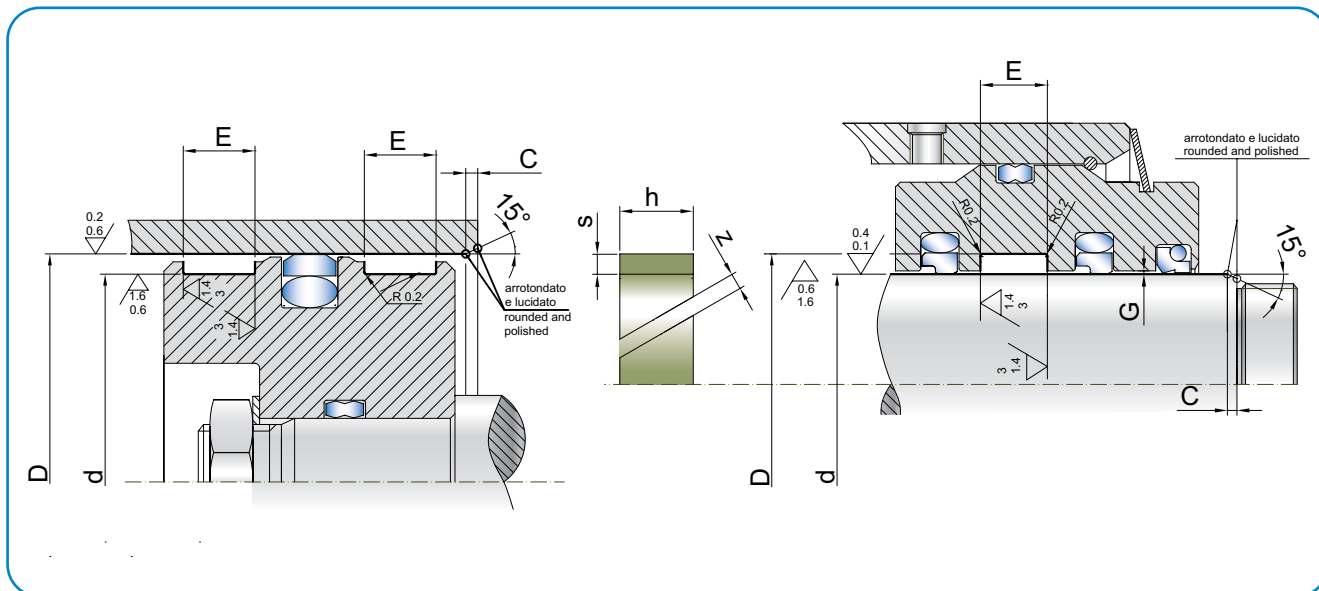
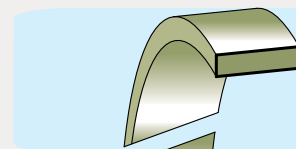
**NG****Oleodinamica
Hydraulic**

Dimensione sede - Groove dimension					
d_{H9}	D_{H9}	$E_{+0.2}$	Spessore anello Ring thickness s	z	
8-20	$d + 2s$	3,20	1,50	1,0-2,0	
15-35	$d + 2s$	4,20	1,50 2,00	1,0-2,0	
15-75	$d + 2s$	5,60	1,50 2,00 2,50	1,5-3,5	
20-75	$d + 2s$	6,30	1,50 2,00 2,50	1,5-3,5	
30-250	$d + 2s$	8,10	1,50 2,00 2,50	2,0-5,0	
35-300	$d + 2s$	9,70	1,50 2,00 2,50 3,00	2,0-6,0	
120-400	$d + 2s$	15,00	1,50 2,00 2,50 3,00	4,0-8,0	
200-900	$d + 2s$	20,00	1,50 2,00 2,50 3,00	4,5-8,0	
300-900	$d + 2s$	25,00	2,00 2,50 3,00	6,0-8,0	
300-900	$d + 2s$	30,00	2,00 2,50 3,00	6,0-10,0	

Nota: altre dimensioni non a catalogo a richiesta. Consultare il nostro ufficio tecnico.

Remark: please contact our technical dept. for further dimensions not included in the catalogue.

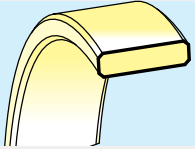

HPW

GUIDA TIPO HPW

Descrizione

Le HPW sono guide in resina fenolica e sono intercambiabili con quelle in materiale termoplastico.

Progettate per stelo e pistone sono ricavate da un tubo per tornitura, lavorazione che garantisce un'alta precisione di spessore. Utilizzate in impieghi decisamente gravosi, sopportano carichi molto elevati.

Dati Tecnici

Velocità: < 1 m/s
 Temperatura: da - 50° C a + 150° C
 Fluidi: oli idraulici a base minerale
 (v. tabella 3 a p. 14)

Materiale

I materiali utilizzabili sono:

- resina fenolica impregnata in trecce di cotone naturale impiegata per carichi medio/bassi
Codice materiale: S0
- resina fenolica impregnata in trecce di poliestere additivata con PTFE.
Codice materiale: S1
- resina fenolica impregnata in trecce di poliestere additivata con grafite
Codice materiale: S3

Montaggio

La guida tagliata e l'ottima elasticità semplificano il montaggio, mentre la presenza di smussi sui due lati facilita l'inserimento dello stelo o del pistone.

Nota: sezione tecnica guide p.158

HPW TYPE WEAR RING

Description

HPW phenolic resin guides can be interchangeable with other thermoplastic wear rings. They can be used for rods or pistons. They are produced from tubes with high thickness accuracy, supporting very high loads and are used in very heavy conditions.

Technical Data

Speed: < 1 m/s
 Temperature: from - 50° C a + 150° C
 Fluids: hydraulic mineral oil
 (see table 3, page 14)

Material

The materials used could be :

- *impregnated phenolic resin in natural cotton braids for low/medium load
Compound reference: S0*
- *impregnated phenolic resin with polyester braids filled PTFE.
Compound reference: S1*
- *impregnated phenolic resin with polyester braids filled graphite
Compound: S3*

Assembling

The assembling can be easily done since the wear ring is cut and extremely elastic. The chamfers on both sides have been studied to better insert the wear ring in the rod or piston.

Note: wear rings technical section p.158



HPW

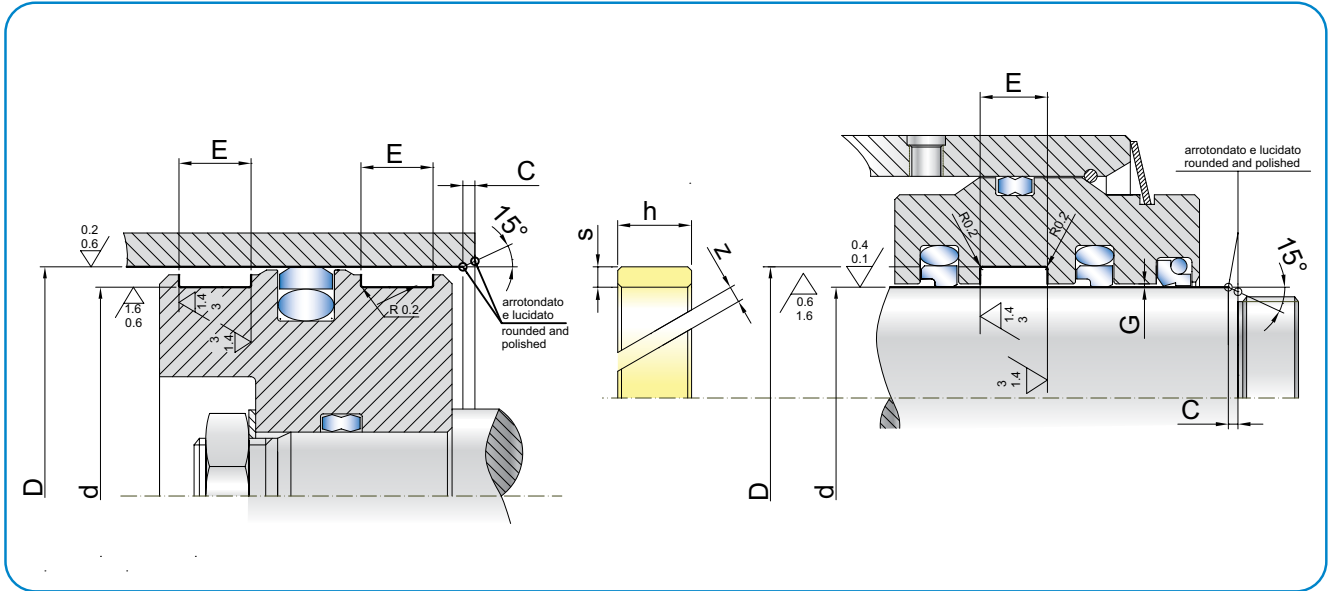
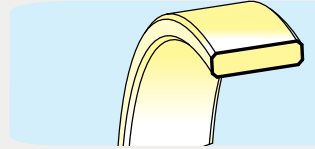

Oleodinamica
Hydraulic

df8	DH9	E +0.2	E +0.2	E +0.2	ART / ITEM
40,0	45,0	5,6	9,7		HPW 0400 0450 056-097 So
45,0	50,0	5,6	9,7		HPW 0450 0500 056-097 So
50,0	55,0	5,6	9,7		HPW 0500 0550 056-097 So
55,0	60,0	5,6	9,7		HPW 0550 0600 056-097 So
56,0	61,0	5,6	9,7		HPW 0560 0610 056-097 So
60,0	65,0	5,6	9,7		HPW 0600 0650 056-097 So
65,0	70,0	5,6	9,7		HPW 0650 0700 056-097 So
70,0	75,0	5,6	9,7		HPW 0700 0750 056-097 So
75,0	80,0	5,6	9,7		HPW 0750 0800 056-097 So
80,0	85,0	9,7	12,8	15,0	HPW 0800 0850 097-128-150 So
85,0	90,0	9,7	12,8	15,0	HPW 0850 0900 097-128-150 So
90,0	95,0	9,7	12,8	15,0	HPW 0900 0950 097-128-150 So
95,0	100,0	9,7	12,8	15,0	HPW 0950 1000 097-128-150 So
100,0	105,0	9,7	12,8	15,0	HPW 1000 1050 097-128-150 So
105,0	110,0	9,7	12,8	15,0	HPW 1050 1100 097-128-150 So
110,0	115,0	9,7	12,8	15,0	HPW 1100 1150 097-128-150 So
115,0	120,0	9,7	12,8	15,0	HPW 1150 1200 097-128-150 So
120,0	125,0	9,7	12,8	15,0	HPW 1200 1250 097-128-150 So
125,0	130,0	9,7	12,8	15,0	HPW 1250 1300 097-128-150 So
130,0	135,0	9,7	12,8	15,0	HPW 1300 1350 097-128-150 So
135,0	140,0	9,7	12,8	15,0	HPW 1350 1400 097-128-150 So
140,0	145,0	9,7	12,8	15,0	HPW 1400 1450 097-128-150 So
145,0	150,0	9,7	12,8	15,0	HPW 1450 1500 097-128-150 So
150,0	155,0	9,7	12,8	15,0	HPW 1500 1550 097-128-150 So

df8	DH9	E +0.2	E +0.2	E +0.2	ART / ITEM
155,0	160,0	9,7	12,8	15,0	HPW 1550 1600 097-128-150 So
160,0	165,0	9,7	12,8	15,0	HPW 1600 1650 097-128-150 So
165,0	170,0	9,7	12,8	15,0	HPW 1650 1700 097-128-150 So
170,0	175,0	9,7	12,8	15,0	HPW 1700 1750 097-128-150 So
175,0	180,0	9,7	12,8	15,0	HPW 1750 1800 097-128-150 So
180,0	185,0	9,7	12,8	15,0	HPW 1800 1850 097-128-150 So
185,0	190,0	9,7	12,8	15,0	HPW 1850 1900 097-128-150 So
190,0	195,0	9,7	12,8	15,0	HPW 1900 1950 097-128-150 So
195,0	200,0	9,7	12,8	15,0	HPW 1950 2000 097-128-150 So
200,0	205,0	9,7	12,8	15,0	HPW 2000 2050 097-128-150 So
205,0	210,0	9,7	12,8	15,0	HPW 2050 2100 097-128-150 So
210,0	215,0	9,7	12,8	15,0	HPW 2100 2150 097-128-150 So
215,0	220,0	\	15,0	25,0	HPW 2150 2200 150-250 So
220,0	225,0	\	15,0	25,0	HPW 2200 2250 150-250 So
225,0	230,0	\	15,0	25,0	HPW 2250 2300 150-250 So
230,0	235,0	\	15,0	25,0	HPW 2300 2350 150-250 So
235,0	240,0	\	15,0	25,0	HPW 2350 2400 150-250 So
240,0	245,0	\	15,0	25,0	HPW 2400 2450 150-250 So
245,0	250,0	\	15,0	25,0	HPW 2450 2500 150-250 So
250,0	255,0	\	15,0	25,0	HPW 2500 2550 150-250 So

Nota: altre dimensioni non a catalogo a richiesta. Consultare il nostro ufficio tecnico.

Remark: please contact our technical dept. for further dimensions not included in the catalogue.

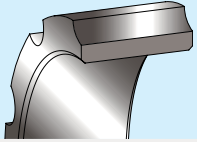

HEN

GUIDA TIPO HEN

Descrizione

Le HEN sono guide studiate per i cilindri tuffanti, in alternativa alle tradizionali boccole in bronzo. Duplice la loro funzione: mantenere in guida lo stelo sulla camicia e fungere da finecorsa. Il passaggio dell'olio è garantito dalle grandi scanalature presenti sul diametro esterno.

Dati Tecnici

Velocità: < 0,8 m/s
 Temperatura: da - 40° C a + 115° C
 Fluidi: oli idraulici a base minerale
 (v. tabella 3 a p.14)

Materiale

Il materiale è una resina poliacetalica rinforzata con fibra di vetro.
 Per temperature di esercizio superiori ai 115°C il materiale è una resina poliammidica rinforzata.
 Codice materiale per temp. <115°C:Ro
 Codice materiale per temp >115°C:R1

Montaggio

La guida tagliata e l'ottima elasticità semplificano il montaggio, mentre la presenza di smussi sui due lati facilita l'inserimento dello stelo.

Nota: sezione tecnica guide p.158

HEN TYPE WEAR RING

Description

The HEN wear rings are designed especially for the plunger cylinders, in substitution to the traditional bronze bushings. It has a double function: it keeps the rod in guide on the bore and acts as a limit switch, the oil passage is guaranteed by the large grooves on the external diameter.

Technical Data

Speed: < 0,8 m/s
 Temperature: from - 40° C a + 115° C
 Fluids: hydraulic mineral oil
 (see table 3, page 14)

Material

*The material is a polyacetal resin reinforced with fibreglass.
 For working temperatures higher than 115° C, the material is a reinforced polyamide resin.
 Compound reference for temp < 115°C: Ro
 Compound reference for temp > 115°C: R1*

Assembling

*The assembling can be easily done since the wear ring is cut and extremely elastic.
 The chamfers on both sides have been studied to better insert the wear ring in the rod.*

Note: wear rings technical section p.158



HEN

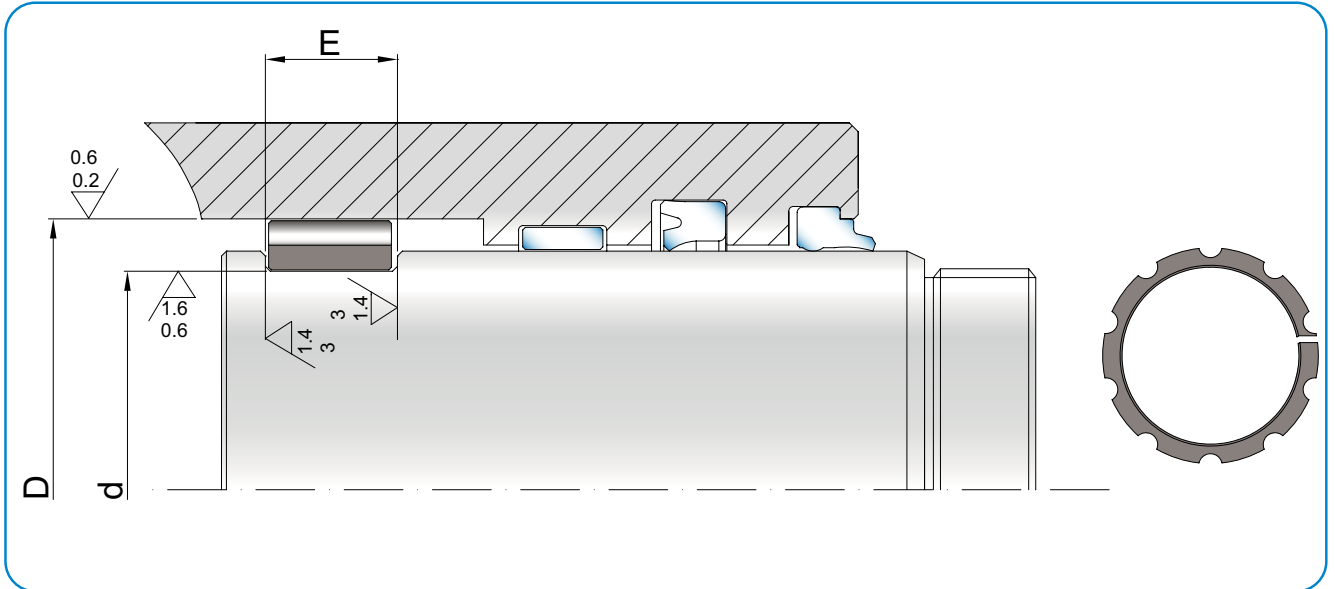
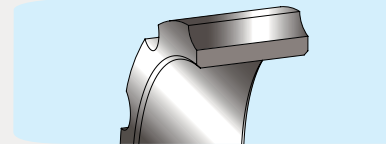

Oleodinamica
Hydraulic

D_{H9}	d_{f8}	$E_{+0,2}$	ART / ITEM			
30,0	20,0	13,0	HEN 0300	0200	130	Ro
35,0	25,0	13,0	HEN 0350	0250	130	Ro
40,0	30,0	13,0	HEN 0400	0300	130	Ro
45,0	35,0	13,0	HEN 0450	0350	130	Ro
50,0	40,0	16,0	HEN 0500	0400	160	Ro
55,0	45,0	16,0	HEN 0550	0450	160	Ro
60,0	50,0	16,0	HEN 0600	0500	160	Ro
65,0	55,0	16,0	HEN 0650	0550	160	Ro
70,0	60,0	16,0	HEN 0700	0600	160	Ro
75,0	65,0	16,0	HEN 0750	0650	160	Ro
80,0	70,0	16,0	HEN 0800	0700	160	Ro
85,0	75,0	16,0	HEN 0850	0750	160	Ro

Nota: altre dimensioni non a catalogo a richiesta. Consultare il nostro ufficio tecnico.

Remark: please contact our technical dept. for further dimensions not included in the catalogue.

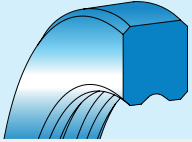

GDR

TENUTA ROTANTE TIPO GDR

Descrizione

La tenuta per movimenti rotativi tipo GDR è una guarnizione simmetrica con due lati di tenuta per giunti girevoli. La simmetria del profilo ha lo scopo di facilitare il montaggio.

Dati tecnici

Pressione: < 350 bar
 Velocità: < 0,3 m/s
 Temperatura: da - 35° C a + 100° C
 Fluidi: oli minerali
 (v. tabella 3 a p. 14)
 Rugosità superficie: dac Ra 0,1 um a Ra 0,4 um

Materiale

Il materiale proposto è il poliuretano tipo Co ad alto modulo elastico, basso compression-set, alta resistenza all'abrasione.
 Ha una durezza di 93 Shore A ± 2.
 Codice materiale: Co

Montaggio

Il montaggio avviene in cava anulare. Per la sua flessibilità, la guarnizione non necessita di utensili di montaggio.
 Eliminare spigoli e bave che possano danneggiare la guarnizione durante l'installazione.

GDR TYPE ROTARY SEAL

Description

The seal for rotary type GDR is a symmetric two-sided seal for swivel joints.
 The symmetry created has the purpose to facilitate the assembly.

Technical data

Pressure: < 350 bar
 Speed: < 0.3 m/s
 Temperature: from - 35° C to + 100° C
 Fluids: mineral oil
 (see table 3, page 14)
 Surface Roughness: from Ra 0,1 um to Ra 0,4 um

Material

The proposed material is a "Co" type polyurethane, with high elasticity modulus, low compression-set and high abrasion resistance.
 The hardness is 93 Shore A ± 2.
 Compound reference: Co

Assembling

Installation is in the annular groove.
 For its flexibility does not need installation tools.
 Remove burrs and sharp edges that could damage the seal during installation.

Tab.42 gioco di accoppiamento / coupling clearance

pressione / pressure BAR	G mm
50	0,50
100	0,30
200	0,20
300	0,10



GDR

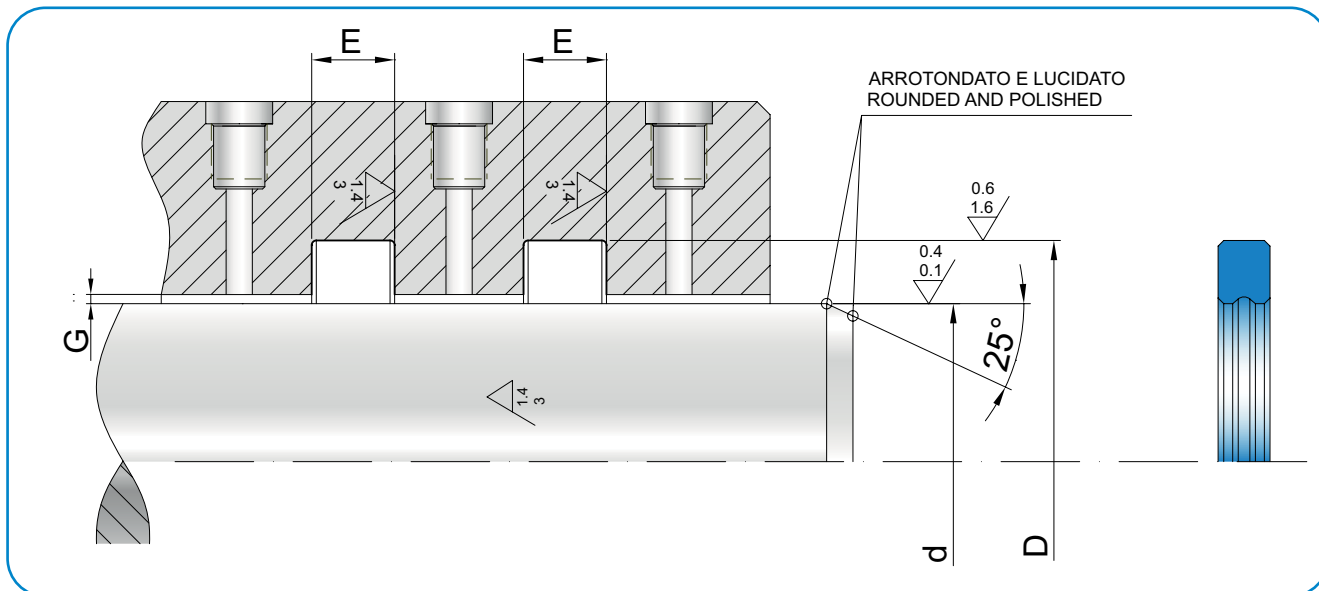
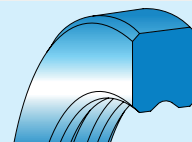

Oleodinamica
Hydraulic

d_{fs}	D_{H10}	$E_{+0,3}$	C	ART / ITEM				
70,0	80,0	5,0	5,0	GDR	0700	0800	050	Co
80,0	90,0	5,0	5,0	GDR	0800	0900	050	Co
90,0	100,0	5,0	5,0	GDR	0900	1000	050	Co
95,0	105,0	5,0	5,5	GDR	0950	1050	050	Co
100,0	110,0	5,0	5,5	GDR	1000	1100	050	Co
110,0	120,0	5,0	5,5	GDR	1100	1200	050	Co
115,0	125,0	5,0	6,0	GDR	1150	1250	050	Co
120,0	130,0	5,0	6,0	GDR	1200	1300	050	Co
125,0	135,0	5,0	6,0	GDR	1250	1350	050	Co

Nota: altre dimensioni non a catalogo a richiesta. Consultare il nostro ufficio tecnico.

Remark: please contact our technical dept. for further dimensions not included in the catalogue.

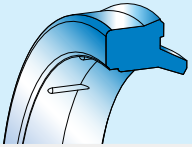

WSL

RASCHIATORE STELO TIPO WSL

Descrizione

Il raschiatore tipo WSL presenta due labbri: uno raschiante e molto flessibile nella parte dinamica e uno sporgente, più corto e molto robusto, nella parte statica. Questo profilo speciale, sia dal lato stelo sia dal lato esterno statico, impedisce alle impurità (scorie, acqua e altro) di penetrare, danneggiare la guarnizione di tenuta e corrodere l'interno del cilindro.

Dati tecnici

Velocità: < 0,8 m/s

Temperatura: da - 35° C a + 100 ° C con punte fino a 110° C.

Fluidi: agenti atmosferici, acqua a temperatura inferiore a 60° C, oli a base minerale (v. tabella 3 a p. 14)

Materiale

I materiali utilizzati sono dei poliuretani resistenti all'abrasione e agli agenti atmosferici, con alto modulo elastico. Il materiale standard è di durezza 93 Shore A ± 2. In alternativa, e previo consulto con il nostro ufficio tecnico, sono utilizzabili poliuretani di durezza superiore, come nel caso di condizioni gravose in ambienti molto inquinanti.

Codice materiale: Co

Montaggio

Il montaggio è privo di problemi particolari grazie alla sede semiaperta collocata nella parte più vicina all'esterno del cilindro. Per evitare di incidere il raschiatore durante il montaggio è importante eliminare gli spigoli taglienti e le bave. Per ulteriori informazioni leggere le istruzioni a p. 63.

WSL TYPE ROD WIPER

Description

The WSL wiper has a high flexible wiping lip on the dynamic side and a strong, shorter, protruding lip on the static side.

This special profile keeps the rod and the static side where it is housed free from any impurity, waste or water.

Impurities would damage the seal and corrode the inner part of the cylinder.

Technical data

Speed: < 0.8 m/s

Temperature: from - 35° C to + 100 ° C with peaks till 110° C.

Fluids: atmospheric factors, water at a temperature below 60° C, mineral oils (see table 3, page 14)

Material

The material used is a polyurethane with a high modulus of elasticity, low compression set and high wear resistance.

Its hardness is 93 Shore A ± 2.

Compound reference: Co

Assembling

It is not very problematic as it can be done in semi-open groove located in the nearest part outside the cylinder.

Remove cutting edges and flashes to avoid the scratching of the wiper during the installation.

For further information please refer to the installation instructions on page 63.



WSL

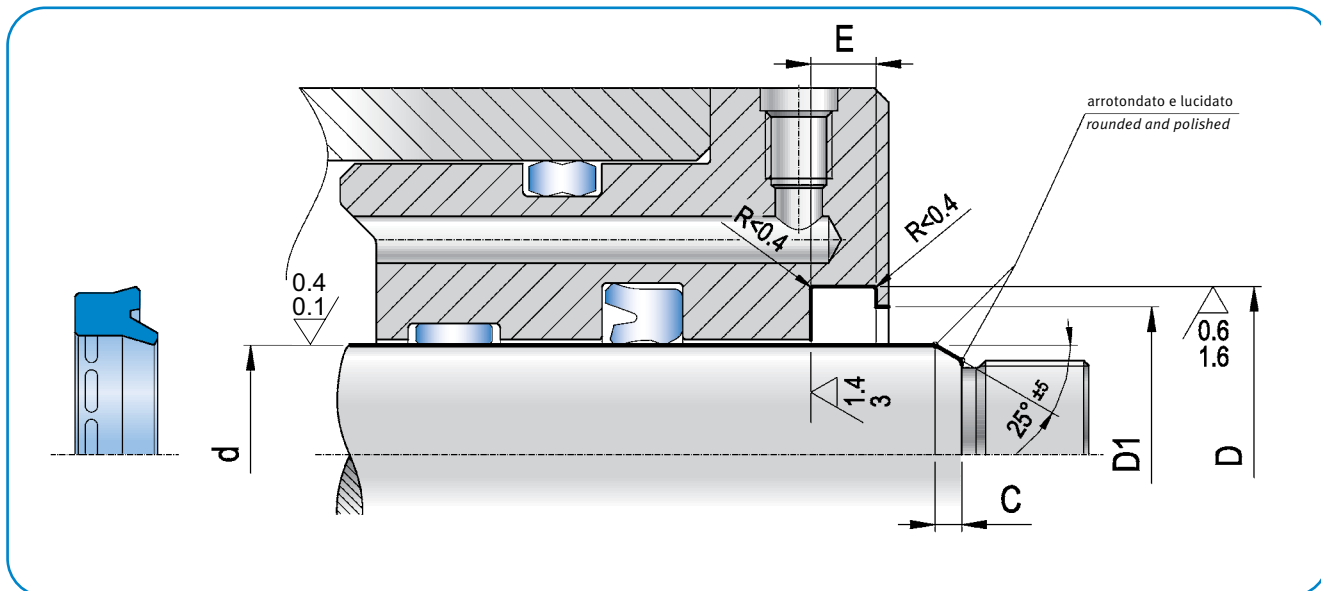

d_{hg}	D_{H10}	$E_{+0,2}$	$D_{1\ 0/+0,2}$	ART / ITEM				
5,0	12,0	2,8	8,0	WSL	0050	0120	028	Co
6,0	12,0	3,0	9,0	WSL	0060	0120	030	Co
8,0	14,6	3,8	11,0	WSL	0080	0146	038	Co
10,0	15,0	1,0	13,0	WSL	0100	0150	010	Co
10,0	16,6	3,8	13,0	WSL	0100	0166	038	Co
12,0	18,6	3,8	15,0	WSL	0120	0186	038	Co
13,0	19,6	3,8	16,0	WSL	0130	0196	038	Co
14,0	20,6	3,8	17,0	WSL	0140	0206	038	Co
15,0	21,6	3,8	18,0	WSL	0150	0216	038	Co
16,0	22,6	3,8	19,0	WSL	0160	0226	038	Co
18,0	24,6	3,8	21,0	WSL	0180	0246	038	Co
20,0	28,6	5,3	23,0	WSL	0200	0286	053	Co
22,0	30,6	5,3	25,0	WSL	0220	0306	053	Co
24,0	32,6	5,3	27,0	WSL	0240	0326	053	Co
25,0	33,6	5,3	28,0	WSL	0250	0336	053	Co
26,0	34,6	5,3	29,0	WSL	0260	0346	053	Co
28,0	36,0	5,0	31,0	WSL	0280	0360	050	Co
28,0	36,6	5,3	31,0	WSL	0280	0366	053	Co
30,0	38,0	5,3	33,0	WSL	0300	0380	053	Co
30,0	38,6	5,3	33,0	WSL	0300	0386	053	Co
32,0	40,0	5,0	35,0	WSL	0320	0400	050	Co
32,0	40,6	5,3	35,0	WSL	0320	0406	053	Co
35,0	43,6	5,3	38,0	WSL	0350	0436	053	Co
36,0	44,6	5,3	39,0	WSL	0360	0446	053	Co
38,0	46,6	5,3	41,0	WSL	0380	0466	053	Co
40,0	48,6	5,3	43,0	WSL	0400	0486	053	Co
40,0	50,0	5,0	43,0	WSL	0400	0500	050	Co

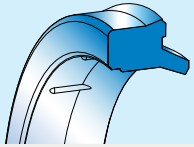

WSL

d _{h9}	D _{H10}	E _{+0,2}	D _{10/+0,2}	ART / ITEM			
40,0	50,0	5,3	43,0	WSL 0400	0500	053	Co
45,0	53,6	5,3	48,0	WSL 0450	0536	053	Co
45,0	55,0	5,3	48,0	WSL 0450	0550	053	Co
46,0	54,6	5,3	49,0	WSL 0460	0546	053	Co
50,0	58,0	5,3	53,0	WSL 0500	0580	053	Co
50,0	58,6	5,3	53,0	WSL 0500	0586	053	Co
50,0	60,0	5,3	53,0	WSL 0500	0600	053	Co
55,0	63,6	5,3	58,0	WSL 0550	0636	053	Co
55,0	65,0	6,3	58,0	WSL 0550	0650	063	Co
55,0	65,6	5,3	58,0	WSL 0550	0656	053	Co
56,0	64,6	5,3	59,0	WSL 0560	0646	053	Co
60,0	68,0	5,3	63,0	WSL 0600	0680	053	Co
60,0	68,6	5,3	63,0	WSL 0600	0686	053	Co
60,0	70,0	5,0	63,0	WSL 0600	0700	050	Co
60,0	70,0	6,3	63,0	WSL 0600	0700	063	Co
61,0	69,6	5,3	64,0	WSL 0610	0696	053	Co
63,0	71,6	5,3	66,0	WSL 0630	0716	053	Co
63,0	71,3	6,0	66,0	WSL 0630	0713	060	Co
65,0	73,6	5,3	68,0	WSL 0650	0736	053	Co
70,0	78,6	5,3	73,0	WSL 0700	0786	053	Co
70,0	80,0	5,0	73,0	WSL 0700	0800	050	Co
70,0	82,2	7,1	76,0	WSL 0700	0822	071	Co
70,0	82,6	7,1	76,0	WSL 0700	0826	071	Co
75,0	83,0	5,3	78,0	WSL 0750	0830	053	Co
75,0	83,6	5,3	78,0	WSL 0750	0836	053	Co
75,0	85,0	6,3	81,0	WSL 0750	0850	063	Co
75,0	87,2	7,1	81,0	WSL 0750	0872	071	Co
76,0	84,6	5,3	79,0	WSL 0760	0846	053	Co
78,0	88,6	5,5	83,0	WSL 0780	0886	053	Co
80,0	88,6	5,3	83,0	WSL 0800	0886	053	Co
80,0	90,0	5,3	83,0	WSL 0800	0900	053	Co
80,0	90,2	7,1	83,0	WSL 0800	0902	071	Co
80,0	92,6	7,1	83,0	WSL 0800	0926	071	Co
85,0	93,6	5,3	88,0	WSL 0850	0936	053	Co
85,0	97,2	7,1	91,0	WSL 0850	0972	071	Co
90,0	98,0	5,3	96,0	WSL 0900	0980	053	Co
90,0	102,2	7,1	96,0	WSL 0900	1022	071	Co
91,0	99,6	5,3	97,0	WSL 0910	0996	053	Co
95,0	107,2	7,1	101,0	WSL 0950	1072	071	Co
97,0	105,6	5,3	103,0	WSL 0970	1056	053	Co
100,0	108,6	5,3	103,0	WSL 1000	1086	053	Co
100,0	112,2	7,1	106,0	WSL 1000	1122	071	Co
105,0	113,0	5,3	108,0	WSL 1050	1130	053	Co
105,0	113,6	5,3	108,0	WSL 1050	1136	053	Co
105,0	117,2	7,1	111,0	WSL 1050	1172	071	Co



WSL

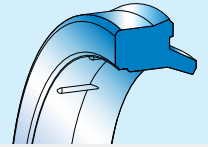

d _{hg}	D _{H10}	E _{+0,2}	D _{1 0/+0,2}	ART / ITEM				
107,0	115,6	5,3	110,0	WSL	1070	1156	053	Co
110,0	118,6	5,3	113,0	WSL	1100	1186	053	Co
110,0	122,2	7,1	116,0	WSL	1100	1222	071	Co
115,0	127,2	7,1	121,0	WSL	1150	1272	071	Co
120,0	132,2	7,1	126,0	WSL	1200	1322	071	Co
125,0	137,2	7,1	131,0	WSL	1250	1372	071	Co
126,0	134,6	5,3	129,0	WSL	1260	1346	053	Co
130,0	142,2	7,1	136,0	WSL	1300	1422	071	Co
135,0	147,2	7,1	141,0	WSL	1350	1472	071	Co
140,0	152,2	7,1	146,0	WSL	1400	1522	071	Co
140,0	155,0	9,0	146,5	WSL	1400	1550	090	Co
145,0	157,2	7,1	151,0	WSL	1450	1572	071	Co
150,0	162,2	7,1	156,0	WSL	1500	1622	071	Co
160,0	172,2	7,1	166,0	WSL	1600	1722	071	Co
160,0	175,2	10,1	168,0	WSL	1600	1752	101	Co
170,0	185,2	10,1	178,0	WSL	1700	1852	101	Co
180,0	195,2	10,1	188,0	WSL	1800	1952	101	Co
180,0	200,2	10,2	183,0	WSL	1800	2002	102	Co
190,0	205,2	10,1	198,0	WSL	1900	2052	101	Co
200,0	215,2	10,1	208,0	WSL	2000	2152	101	Co
210,0	225,2	10,1	218,0	WSL	2100	2252	101	Co
220,0	235,2	10,1	228,0	WSL	2200	2352	101	Co
230,0	245,2	10,1	238,0	WSL	2300	2452	101	Co
240,0	255,2	10,1	248,0	WSL	2400	2552	101	Co
250,0	265,2	10,1	258,0	WSL	2500	2652	101	Co

Nota: altre dimensioni non a catalogo a richiesta. Consultare il nostro ufficio tecnico.

Remark: please contact our technical dept. for further dimensions not included in the catalogue.

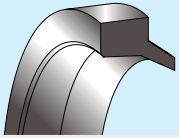

R06

RASCHIATORE STELO TIPO R06

Descrizione

Gli anelli raschiatori della serie Ro6 sono utilizzati per impedire l'ingresso di impurità all'interno di apparecchiature oleodinamiche e proteggere le guarnizioni e le parti metalliche che altrimenti potrebbero danneggiarsi.

Dati tecnici

Velocità: < 0,8 m/s
 Temperatura: da -30° C a +100 ° C con punte fino a 110° C.
 Fluidi: agenti atmosferici, acqua a temperatura inferiore a 60° C, oli a base minerale
 (v. tabella 3 a p. 14)

Materiale

Il materiale standard utilizzato è NBR 90 ShoreA. Per le temperature elevate (da -15°C a +200°C) si consiglia l'utilizzo di FPM 90 Shore A.

Montaggio

Privo di particolari problemi grazie alla sede semiaperta collocata nella parte più vicina all'esterno del cilindro.
 Per evitare di incidere il raschiatore durante il montaggio si raccomanda di eliminare gli spigoli taglienti e le bave.
 Per ulteriori informazioni leggere le istruzioni a p. 63.

R06 TYPE ROD WIPER

Description

The wiper rings of the series Ro6 are used to prevent the entry of impurities inside of hydraulic equipment, thus protecting both the seals and the metal parts that might otherwise be damaged.

Technical data

Speed: < 0.8 m/s
 Temperature: from -30° C to +100 ° C with peaks till 110° C.
 Fluids: atmospheric factors, water at a temperature below 60° C, mineral oils
 (see table 3, page 14)

Material

the standard material used is NBR 90 ShoreA. For high temperatures (from -15 ° C to +200 ° C), we recommend the use of FPM 90 Shore A.

Assembling

It is not very problematic as it can be done in semi-open groove located in the nearest part outside the cylinder.
 Remove cutting edges and flashes to avoid the scratching of the wiper during the installation.
 For further information please refer to the installation instructions on page 63.



R06

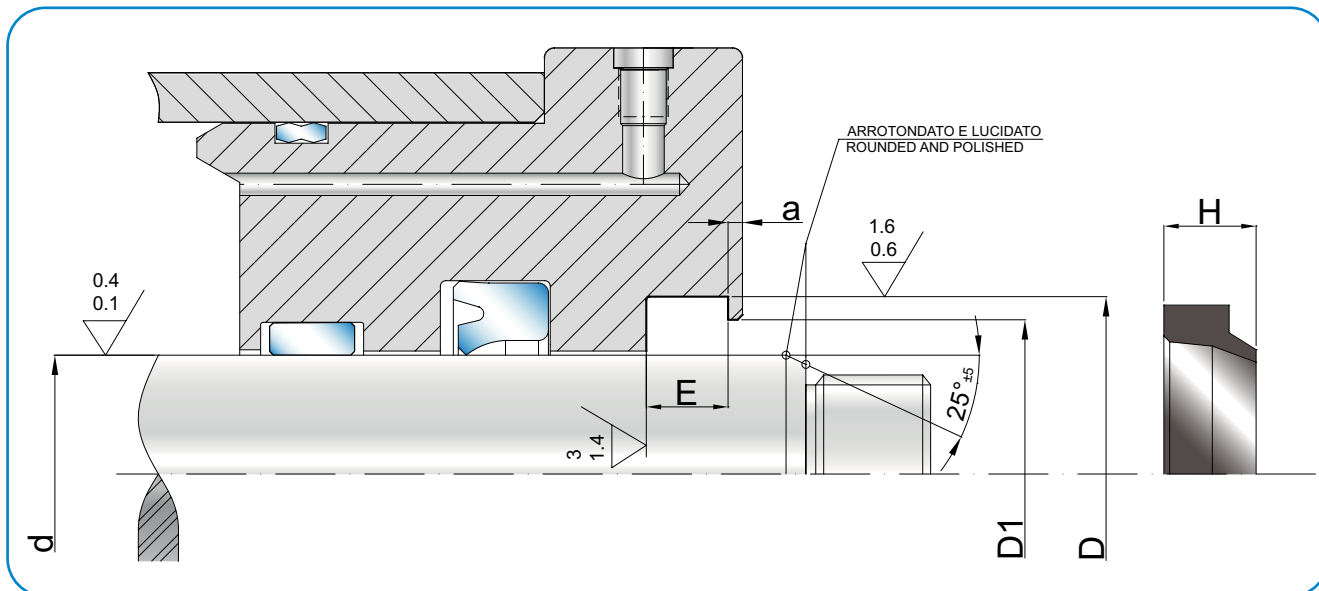
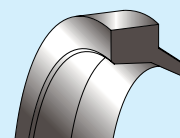

Oleodinamica
Hydraulic

d _{h9}	D _{H10}	D ₁	E _{+0,2}	H	a	ART / ITEM
12,0	18,6	15,0	3,8	5,0	2,0	Ro6 1218
13,0	19,6	16,0	3,8	5,0	2,0	Ro6 1319
15,0	21,6	18,0	3,8	5,0	2,0	Ro6 1521
16,0	22,6	19,0	3,8	5,0	2,0	Ro6 1622
17,0	23,6	20,0	3,8	5,0	2,0	Ro6 1723
18,0	24,6	21,0	3,8	5,0	2,0	Ro6 1824
19,0	28,6	22,0	5,3	7,0	2,0	Ro6 1928
20,0	28,6	23,0	5,3	7,0	2,0	Ro6 2028
22,0	30,6	25,0	5,3	7,0	2,0	Ro6 2230
24,0	32,6	27,0	5,3	7,0	2,0	Ro6 2432
25,0	33,6	28,0	5,3	7,0	2,0	Ro6 2533
26,0	34,6	29,0	5,3	7,0	2,0	Ro6 2634
27,0	35,6	30,0	5,3	7,0	2,0	Ro6 2735
28,0	36,6	31,0	5,3	7,0	2,0	Ro6 2836
30,0	38,6	33,0	5,3	7,0	2,0	Ro6 3038
32,0	40,6	35,0	5,3	7,0	2,0	Ro6 3240
33,0	41,6	36,0	5,3	7,0	2,0	Ro6 3341
35,0	43,6	38,0	5,3	7,0	2,0	Ro6 3543
36,0	44,6	39,0	5,3	7,0	2,0	Ro6 3644
38,0	46,6	41,0	5,3	7,0	2,0	Ro6 3846
40,0	48,6	43,0	5,3	7,0	2,0	Ro6 4048
42,0	50,6	45,0	5,3	7,0	2,0	Ro6 4250
45,0	53,6	48,0	5,3	7,0	2,0	Ro6 4553
45,0	55,6	48,0	5,3	7,0	2,0	Ro6 4555
46,0	54,6	49,0	5,3	7,0	2,0	Ro6 4654
48,0	56,6	51,0	5,3	7,0	2,0	Ro6 4856
50,0	58,6	53,0	5,3	7,0	2,0	Ro6 5058

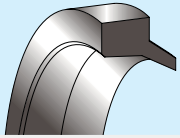

R06

d _{h9}	D _{H10}	D1	E _{+0,2}	H	a	ART / ITEM
50,0	60,6	53,0	5,3	7,0	2,0	R06 5060
53,0	61,6	56,0	5,3	7,0	2,0	R06 5361
28,0	36,0	5,8	6,3	4,5	2,0	R06 1218
55,0	63,6	58,0	5,3	7,0	2,0	R06 5563
55,0	65,6	58,0	5,3	7,0	2,0	R06 5565
56,0	64,6	59,0	5,3	7,0	2,0	R06 5664
56,0	66,6	59,0	5,3	7,0	2,0	R06 5666
60,0	68,6	63,0	5,3	7,0	2,0	R06 6068
60,0	70,6	63,0	5,3	7,0	2,0	R06 6070
63,0	71,6	66,0	5,3	7,0	2,0	R06 6371
63,0	73,6	68,0	5,3	7,0	2,0	R06 6373
65,0	73,6	68,0	5,3	7,0	2,0	R06 6573
65,0	75,6	68,0	5,3	7,0	2,0	R06 6575
70,0	78,6	73,0	5,3	7,0	2,0	R06 7078
70,0	80,6	73,0	5,3	7,0	2,0	R06 7080
70,0	82,6	76,0	7,1	11,5	4,5	R06 7082
73,0	81,6	76,0	5,3	7,0	2,0	R06 7381
75,0	83,6	78,0	5,3	7,0	2,0	R06 7583
75,0	87,2	81,0	7,1	12,0	5,0	R06 7587
76,5	88,7	82,5	7,1	11,5	4,5	R06 7688
78,0	92,2	85,0	7,1	12,0	5,0	R06 7892
80,0	88,6	83,0	5,3	7,0	2,0	R06 8088
80,0	92,6	86,0	7,1	12,0	5,0	R06 8092
83,0	91,6	86,0	5,3	7,0	2,0	R06 8391
85,0	93,6	88,0	5,3	7,0	2,0	R06 8593
85,0	97,2	91,0	7,1	12,0	4,5	R06 8597
88,0	100,2	94,0	7,1	12,5	4,5	R06 88100
90,0	102,2	96,0	7,1	12,0	4,5	R06 90102
95,0	107,2	101,0	7,1	12,5	5,5	R06 95107
97,0	111,0	104,0	7,1	12,0	5,0	R06 97111
100,0	112,2	106,0	7,1	12,0	5,0	R06 100112
103,0	115,2	109,0	7,1	12,5	5,5	R06 103115
104,0	116,2	110,0	7,1	12,5	5,5	R06 104116
105,0	117,2	111,0	7,1	12,5	5,5	R06 105117
110,0	122,2	116,0	7,1	12,0	5,0	R06 110122
115,0	127,2	121,0	7,1	12,0	5,0	R06 115127
116,0	130,2	123,0	7,1	12,0	5,0	R06 116130
118,0	130,2	124,0	7,1	12,5	5,5	R06 118130
120,0	132,2	126,0	7,1	12,5	5,5	R06 120132
125,0	137,2	131,0	7,1	12,5	5,5	R06 125137
125,0	140,0	132,6	10,1	16,0	6,0	R06 125140
127,0	139,2	133,0	7,1	12,5	5,5	R06 127139



R06

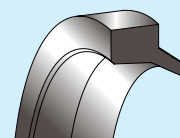

d _{h9}	D _{H10}	D1	E _{+0,2}	H	a	ART / ITEM
130,0	142,2	136,0	7,1	12,5	5,5	R06 130142
135,0	147,2	141,0	7,1	12,5	5,5	R06 135147
135,0	149,2	142,0	7,1	12,0	5,0	R06 135149
140,0	152,2	146,0	7,1	12,5	5,5	R06 140152
140,0	155,2	148,0	10,1	16,0	6,0	R06 140155
145,0	157,2	151,0	7,1	12,5	5,5	R06 145157
146,1	158,3	152,1	7,1	12,5	5,5	R06 146158
150,0	162,2	156,0	7,1	12,5	5,5	R06 150162
150,0	165,2	158,0	10,1	16,0	6,0	R06 150165
155,0	169,2	162,0	7,1	12,0	5,0	R06 155169
160,0	175,2	168,0	10,1	16,0	6,0	R06 160175
170,0	185,2	178,0	10,1	16,0	6,0	R06 170185
175,0	189,2	182,0	7,1	12,0	5,0	R06 175189
180,0	195,2	188,0	10,1	16,0	6,0	R06 180195
180,0	200,0	190,0	10,2	18,0	8,0	R06 180200
196,0	210,2	203,0	7,1	12,0	5,0	R06 196210
200,0	220,0	210,0	10,2	18,0	8,0	R06 200220
219,5	233,7	226,5	7,1	12,0	5,0	R06 219233
244,5	258,7	251,5	7,1	12,0	5,0	R06 244258

Nota: altre dimensioni non a catalogo a richiesta. Consultare il nostro ufficio tecnico.

Remark: please contact our technical dept. for further dimensions not included in the catalogue.

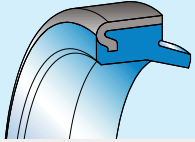

WSG

RASCHIATORE CON GABBIA METALLICA WSG

Descrizione

Composto da un'anima metallica incollata a un elemento in poliuretano, il raschiatore tipo WSG ha la funzione di pulire lo stelo al suo rientro e mantenere le impurità all'esterno del cilindro. La cava aperta facilita l'esecuzione della sede.

Dati tecnici

Velocità: < 0,8 m/s
 Temperatura: da - 35° C a + 100 ° C con punte fino a 110° C.
 Fluidi: agenti atmosferici, acqua a temperatura inferiore a 60° C, oli a base minerale
 (v. tabella 3 a p. 14)

Materiale

Il materiale del raschiatore è un poliuretano di durezza 93 Shore A e anima in acciaio.
 Codice materiale: CA

Montaggio

Il montaggio avviene in cava aperta.
 Togliere gli spigoli vivi e le bave per facilitarne l'inserimento.

Attenzione: La cava dove alloggia il raschiatore deve essere in tolleranza di lavorazione come indicato nella tabella. Il mancato rispetto della misura della tolleranza può causare la fuoriuscita del raschiatore durante il movimento.

WSG TYPE WIPER WITH METAL CAGE

Description

The function of the WSG wiper is to clean the rod while returning to position, blocking external impurities.

It is made up of a metal core bonded to a polyurethane element.

The groove is open and allows easier design of the seat.

Technical data

Speed: < 0.8 m/s
 Temperature: from - 35° C to + 100 ° C with peaks till 110° C.
 Fluids: atmospheric factors, water at a temperature below 60° C, mineral oils
 (see table 3, page 14)

Material

The material of the wiper is a polyurethane with a hardness of 93 Shore A and steel core.
 Compound reference: CA

Assembling

The assembling is done in open groove.
 Remove flashes and cutting edges to allow better installation of the wiper.

**Warning: The housing of the wiper must be within the machining tolerance as shown in the table.
 Not observed tolerances may cause the expulsion of the wiper during the operations.**



WSG

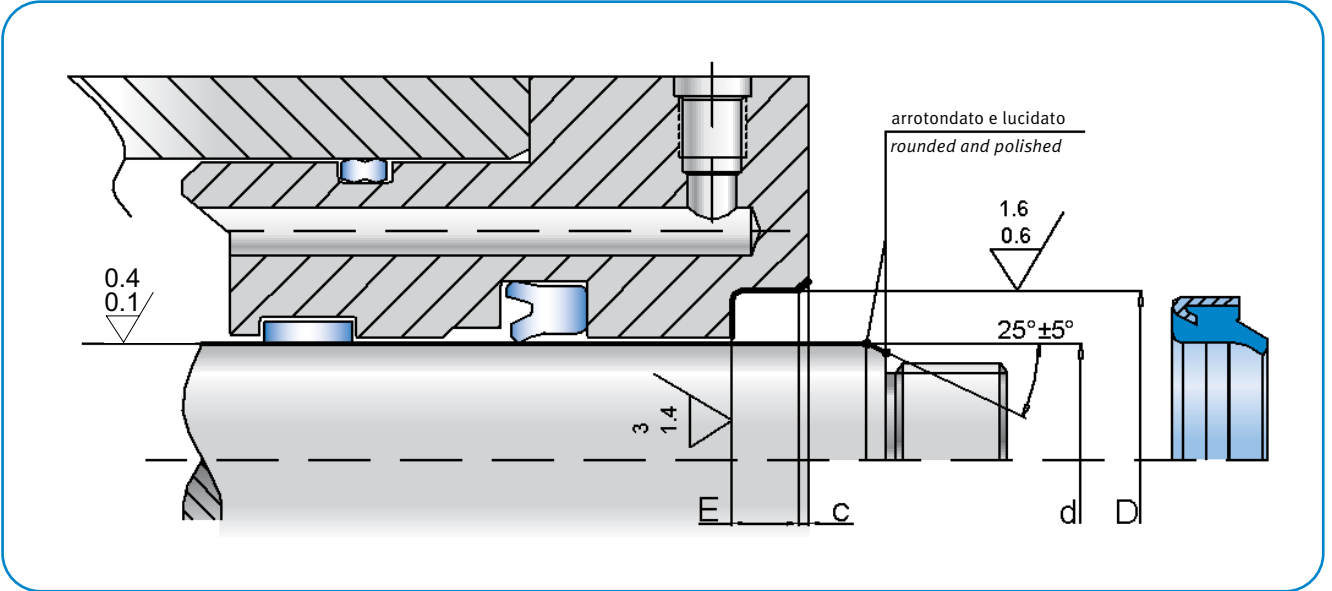
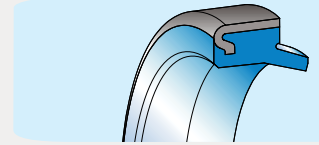

d _{h9}	D _{H10}	Toll.	E _{+0,2}	C	ART / ITEM
20,0	30,0	-0	4,0	0,8	WSG 0200 0300 040 CA
20,0	30,0	+0,033	5,0	1,0	WSG 0200 0300 050 CA
* 20,0	30,0		7,0	1,5	WSG 0200 0300 070 CA
22,0	30,0	-0	4,0	0,8	WSG 0220 0300 040 CA
22,0	32,0	+0,039	5,0	1,0	WSG 0220 0320 050 CA
* 22,0	32,0		7,0	1,5	WSG 0220 0320 070 CA
25,0	35,0	-0	5,0	1,5	WSG 0250 0350 050 CA
* 25,0	35,0	+0,039	7,0	1,5	WSG 0250 0350 070 CA
28,0	38,0		5,0	1,0	WSG 0280 0380 050 CA
28,0	38,0	-0	7,0	1,5	WSG 0280 0380 070 CA
30,0	40,0	+0,039	5,0	1,0	WSG 0300 0400 050 CA
30,0	40,0		7,0	1,5	WSG 0300 0400 070 CA
32,0	42,0	-0	5,0	1,0	WSG 0320 0420 050 CA
32,0	42,0	+0,039	7,0	1,5	WSG 0320 0420 070 CA
35,0	45,0		5,0	1,0	WSG 0350 0450 050 CA
* 35,0	45,0	-0	7,0	1,5	WSG 0350 0450 070 CA
36,0	46,0	+0,039	5,0	1,0	WSG 0360 0460 050 CA
38,0	48,0		7,0	1,0	WSG 0380 0480 070 CA
40,0	50,0	-0	5,0	1,0	WSG 0400 0500 050 CA
* 40,0	50,0	+0,046	7,0	1,5	WSG 0400 0500 070 CA
42,0	52,0		7,0	1,5	WSG 0420 0520 070 CA

d _{h9}	D _{H10}	Toll.	E _{+0,2}	C	ART / ITEM
45,0	55,0	-0	7,0	1,5	WSG 0450 0550 070 CA
50,0	60,0	+0,046	5,0	1,0	WSG 0500 0600 050 CA
* 50,0	60,0		7,0	1,5	WSG 0500 0600 070 CA
55,0	65,0	-0	7,0	1,5	WSG 0550 0650 070 CA
* 56,0	66,0	+0,046	7,0	1,5	WSG 0560 0660 070 CA
60,0	70,0		5,0	1,0	WSG 0600 0700 050 CA
60,0	70,0	-0	7,0	1,5	WSG 0600 0700 070 CA
65,0	75,0	0,046	7,0	1,5	WSG 0650 0750 070 CA
* 70,0	80,0		7,0	1,5	WSG 0700 0800 070 CA
75,0	85,0	-0	7,0	1,5	WSG 0750 0850 070 CA
* 80,0	90,0	+0,054	7,0	1,5	WSG 0800 0900 070 CA
85,0	95,0		7,0	1,5	WSG 0850 0950 070 CA
* 90,0	100,0	-0	7,0	1,5	WSG 0900 1000 070 CA
95,0	105,0	+0,054	7,0	1,5	WSG 0950 1050 070 CA
100,0	110,0		7,0	1,5	WSG 1000 1100 070 CA
110,0	120,0	-0	7,0	1,5	WSG 1100 1200 070 CA
120,0	130,0	+0,063	7,0	1,5	WSG 1200 1300 070 CA

* in conformità alle norme ISO 3320 – in accordance with ISO 3320 norms

Nota: altre dimensioni non a catalogo a richiesta. Consultare il nostro ufficio tecnico.

Remark: please contact our technical dept. for further dimensions not included in the catalogue.



IWP

RASCHIATORE CON GABBIA METALLICA TIPO IWP

Descrizione

Il raschiatore tipo IWP ha la funzione di mantenere pulito lo stelo al rientro nel cilindro. È composto da un inserto metallico incollato a un elemento in poliuretano e ha largo impiego sulle macchine agricole e movimento terra.

Per il limitato ingombro può proteggere snodi, cuscinetti e boccole di rotolamento (pin dust seal). La cava aperta ne facilita il montaggio.

Dati tecnici

Velocità: < 0,8 m/s

Temperatura: da - 35° C a + 100 ° C con punte fino a 110° C.

Fluidi: agenti atmosferici, acqua a temperatura inferiore a 60° C, oli a base minerale
(v. tabella 3 a p. 14)

Materiale

Il materiale utilizzato per il raschiatore è un poliuretano a 93° Shore A. La gabbia metallica è realizzata in acciaio.

Codice Materiale: CA

NORME DIN 1624

Montaggio

Il montaggio è in cava aperta e avviene per interferenza (piantaggio). Togliere gli spigoli vivi ed eseguire lo smusso di invito come da tabella allegata per facilitare il montaggio e non danneggiare la gabbia durante l'inserimento.

Attenzione: La cava dove alloggia il raschiatore deve essere in tolleranza di lavorazione come indicato nella tabella. Il mancato rispetto della misura della tolleranza può causare la fuoriuscita del raschiatore durante il movimento.

IWP TYPE WIPER WITH METAL CAGE

Description

The function of the IWP wiper is cleaning the rod while return into position, blocking external impurities. It is made up of an external metal cage core part glued to a PU element. It has widely used on earth moving machinery and agricultural machinery. For the limited size can be used to protect joints, bearings and bushings rolling (pin dust seal). The groove is open and makes easier the design of the seat.

Technical data

Speed: < 0.8 m/s

Temperature: from - 35° C to + 100 ° C with peaks till 110° C.

Fluids: atmospheric factors, water at a temperature below 60° C, mineral oils
(see table 3, page 14)

Material

The material of the wiper is a polyurethane with a hardness of 93° Shore A and steel core.

Compound reference: CA

NORMS DIN 1624

Assembling

The assembling is done in open groove (interference). Remove flashes and cutting edges to allow better installation of the wiper to facilitate and not damage the cage during insertion.

Warning: The housing of the wiper must be within the machining tolerance as shown in the table.

Not observed tolerances may cause the expulsion of the wiper during the operations.



IWP

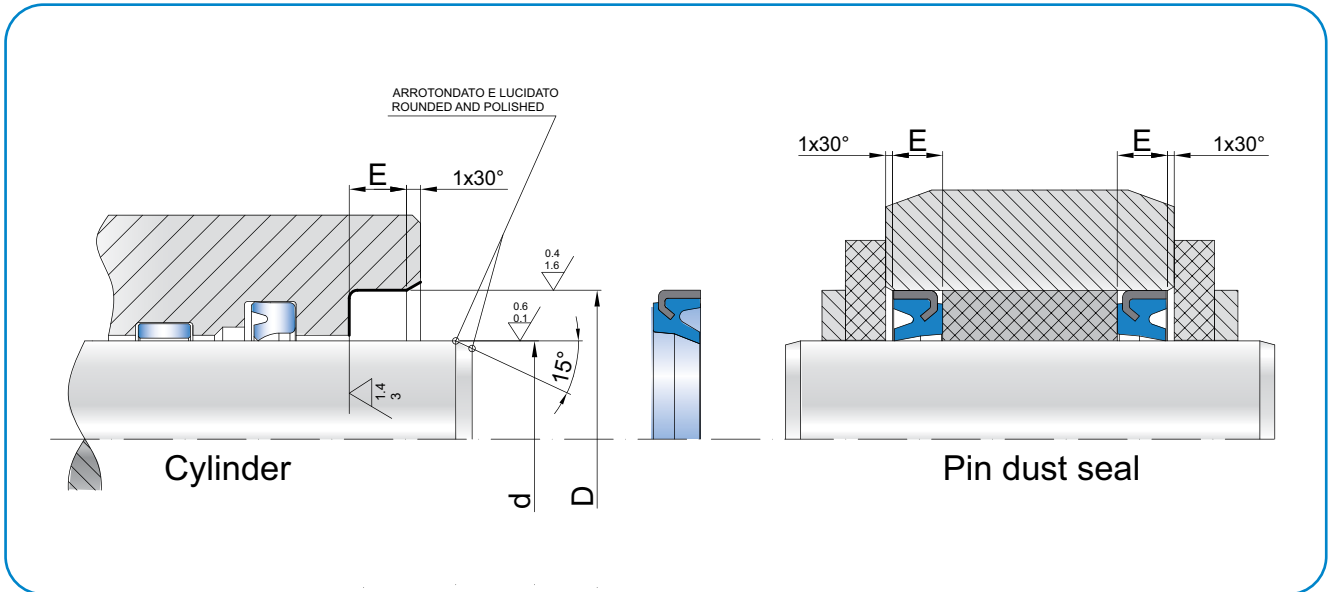
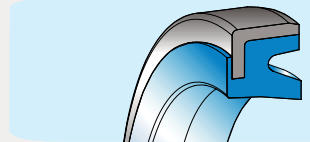

Oleodinamica
Hydraulic

d _{H9}	D _{H8}	Toll _{H8}	E _{+0,2}	ART / ITEM
16,0	30,0	+0,039/0	4,2	IWP 0160 0300 042 CA
18,0	28,0	+0,039/0	4,0	IWP 0180 0280 040 CA
20,0	34,0	+0,039/0	4,2	IWP 0200 0340 042 CA
22,0	32,0	+0,039/0	4,0	IWP 0220 0320 040 CA
25,0	39,0	+0,039/0	5,2	IWP 0250 0390 052 CA
30,0	40,0	+0,039/0	4,0	IWP 0300 0400 040 CA
32,0	45,0	+0,039/0	6,0	IWP 0320 0450 060 CA
35,0	45,0	+0,039/0	4,0	IWP 0350 0450 040 CA
35,0	45,0	+0,039/0	5,0	IWP 0350 0450 050 CA
35,0	45,0	+0,039/0	6,0	IWP 0350 0450 060 CA
38,0	50,0	+0,039/0	5,0	IWP 0380 0500 050 CA
38,0	50,0	+0,039/0	7,5	IWP 0380 0500 075 CA
40,0	50,0	+0,039/0	4,0	IWP 0400 0500 040 CA
40,0	52,0	+0,046/0	6,0	IWP 0400 0520 060 CA
42,0	52,0	+0,046/0	7,0	IWP 0420 0520 070 CA
45,0	55,0	+0,046/0	4,0	IWP 0450 0550 040 CA
45,0	55,0	+0,046/0	3,2	IWP 0450 0550 032 CA
45,0	60,0	+0,046/0	7,5	IWP 0450 0600 075 CA
50,0	60,0	+0,046/0	4,0	IWP 0500 0600 040 CA
50,0	63,0	+0,046/0	4,0	IWP 0500 0630 040 CA
50,0	65,0	+0,046/0	7,5	IWP 0500 0650 075 CA
55,0	65,0	+0,046/0	3,2	IWP 0550 0650 032 CA
55,0	70,0	+0,046/0	7,5	IWP 0550 0700 075 CA
56,0	70,0	+0,046/0	7,5	IWP 0560 0700 075 CA

d _{H9}	D _{H8}	Toll _{H8}	E _{+0,2}	ART / ITEM
60,0	74,0	+0,046/0	8,0	IWP 0600 0740 080 CA
60,0	75,0	+0,046/0	7,5	IWP 0600 0750 075 CA
60,0	75,0	+0,046/0	4,0	IWP 0600 0750 040 CA
63,0	78,0	+0,046/0	7,5	IWP 0630 0780 075 CA
65,0	80,0	+0,046/0	5,0	IWP 0650 0800 050 CA
70,0	80,0	+0,046/0	5,0	IWP 0700 0800 050 CA
70,0	85,0	+0,054/0	4,0	IWP 0700 0850 040 CA
70,0	85,0	+0,054/0	7,5	IWP 0700 0850 075 CA
71,0	86,0	+0,054/0	5,0	IWP 0710 0860 050 CA
75,0	90,0	+0,054/0	7,5	IWP 0750 0900 075 CA
76,5	85,0	+0,054/0	5,0	IWP 0765 0850 050 CA
80,0	95,0	+0,054/0	5,0	IWP 0800 0950 050 CA
80,0	95,0	+0,054/0	7,5	IWP 0800 0950 075 CA
80,0	100,0	+0,054/0	10,0	IWP 0800 1000 100 CA
85,0	100,0	+0,054/0	10,0	IWP 0850 1000 100 CA
90,0	105,0	+0,054/0	6,0	IWP 0900 1050 060 CA
90,0	110,0	+0,054/0	10,0	IWP 0900 1100 100 CA
100,0	115,0	+0,054/0	6,5	IWP 1000 1150 065 CA
100,0	115,0	+0,054/0	7,5	IWP 1000 1150 075 CA
110,0	125,0	+0,063/0	4,0	IWP 1100 1250 040 CA
110,0	125,0	+0,063/0	9,0	IWP 1100 1250 090 CA
115,0	130,0	+0,063/0	7,5	IWP 1150 1300 075 CA
120,0	135,0	+0,063/0	8,0	IWP 1200 1350 080 CA
125,0	140,0	+0,063/0	7,0	IWP 1250 1400 070 CA

Nota: altre dimensioni non a catalogo a richiesta. Consultare il nostro ufficio tecnico.

Remark: please contact our technical dept. for further dimensions not included in the catalogue.

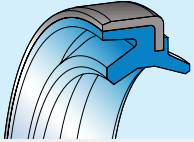

DWP

RASCHIATORE BIDIREZIONALE CON GABBIA METALLICA TIPO DWP

Descrizione

Il raschiatore DWP è di tipo bidirezionale con gabbia metallica. Dotato di funzione raschiante sullo stelo, questo raschiatore presenta un labbro di tenuta che lavora in tandem con la guarnizione primaria. È utilizzato in cilindri di macchine movimento terra dove l'effetto raschiante è molto importante poiché si lavora a contatto con materiali come terra, cemento e ghiaccio.

Dati tecnici

Velocità: < 0,8 m/s
 Temperatura: da - 35° C a + 100 ° C con punte fino a 110° C.
 Fluidi: agenti atmosferici, acqua a temperatura inferiore a 60° C, oli a base minerale
 (v. tabella 3 a p. 14)

Materiale

Il materiale utilizzato per il raschiatore è un poliuretano a 93° Shore A. La gabbia metallica è realizzata in acciaio.
 Codice Materiale: CA
 NORME DIN 1624

Montaggio

Il montaggio è in cava aperta e avviene per interferenza (piantaggio). Togliere gli spigoli vivi ed eseguire lo smusso di invito come da tabella allegata per facilitare il montaggio e non danneggiare la gabbia durante l'inserimento.

Attenzione: La cava dove alloggia il raschiatore deve essere in tolleranza di lavorazione come indicato nella tabella. Il mancato rispetto della misura della tolleranza può causare la fuoriuscita del raschiatore durante il movimento.

DWP TYPE BIDIRECTIONAL WIPER WITH METAL CAGE

Description

The DWP wiper is a bi-directional type with metal cage. Besides the function wiper on the stem has a sealing lip that works in tandem with the primary seal. This type of bi-directional scraper is used in cylinders of earth-moving machines where the effect is very important when the wiper is in contact with earth, concrete, ice etc..

Technical data

Speed: < 0.8 m/s
 Temperature: from - 35° C to + 100 ° C with peaks till 110° C.
 Fluids: atmospheric factors, water at a temperature below 60° C, mineral oils
 (see table 3, page 14)

Material

The material of the wiper is a polyurethane with a hardness of 93° Shore A and steel core.
 Compound reference: CA
 NORMS DIN 1624

Assembling

The assembling is done in open groove (interference). Remove flashes and cutting edges to allow better installation of the wiper to facilitate and not damage the cage during insertion.

Warning: The housing of the wiper must be within the machining tolerance as shown in the table. Not observed tolerances may cause the expulsion of the wiper during the operations.



DWP

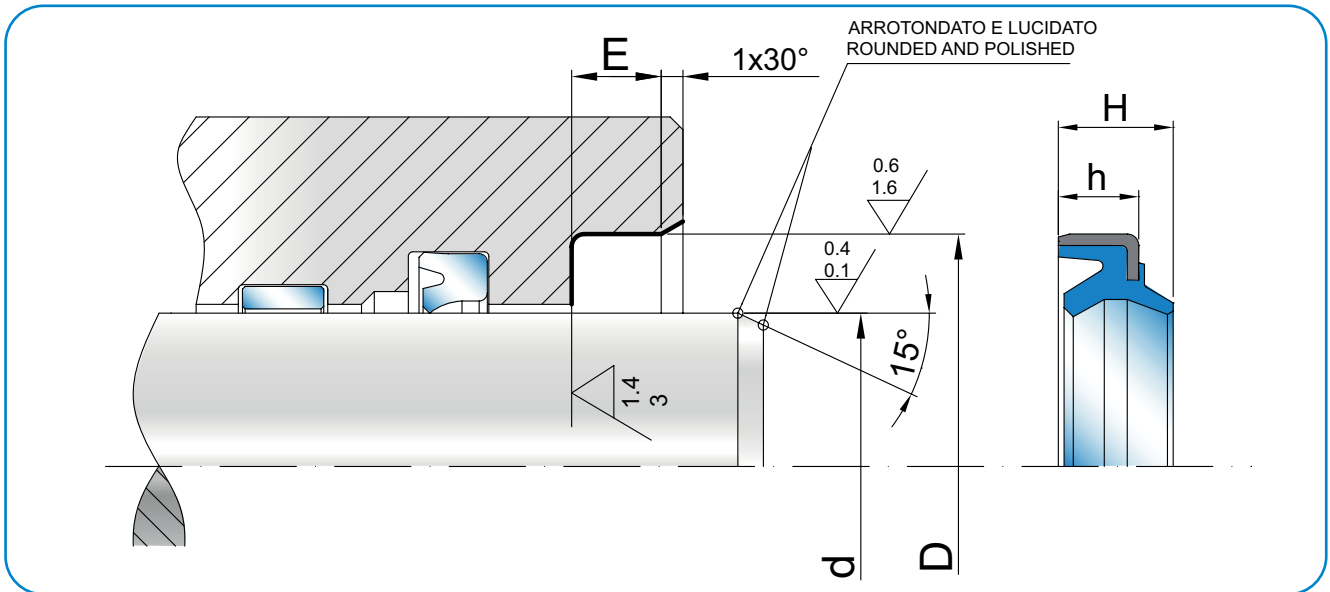
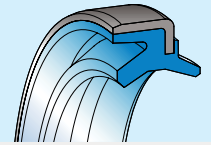

dh ₉	DH ₈	Toll _{H8}	h	H	E + 0,2	ART / ITEM				
20,0	32,0	+0,039/0	6,0	9,0	6,0	DWP	0200	0320	060	CA
25,0	37,0	+0,039/0	6,0	9,0	6,0	DWP	0250	0370	060	CA
30,0	42,0	+0,039/0	6,0	9,0	6,0	DWP	0300	0420	060	CA
32,0	44,0	+0,039/0	7,0	10,0	7,0	DWP	0320	0440	070	CA
34,0	46,0	+0,039/0	7,0	10,0	7,0	DWP	0340	0460	070	CA
35,0	47,0	+0,039/0	7,0	10,0	7,0	DWP	0350	0470	070	CA
38,0	50,0	+0,039/0	7,0	10,0	7,0	DWP	0380	0500	070	CA
40,0	52,0	+0,046/0	7,0	10,0	7,0	DWP	0400	0520	070	CA
45,0	57,0	+0,046/0	7,0	10,0	7,0	DWP	0450	0570	070	CA
50,0	62,0	+0,046/0	7,0	10,0	7,0	DWP	0500	0620	070	CA
55,0	69,0	+0,046/0	8,0	11,0	8,0	DWP	0550	0690	080	CA
60,0	74,0	+0,046/0	8,0	11,0	8,0	DWP	0600	0740	080	CA
63,0	77,0	+0,046/0	8,0	11,0	8,0	DWP	0630	0770	080	CA
65,0	79,0	+0,046/0	8,0	11,0	8,0	DWP	0650	0790	080	CA
70,0	84,0	+0,054/0	8,0	11,0	8,0	DWP	0700	0840	080	CA
75,0	89,0	+0,054/0	8,0	11,0	8,0	DWP	0750	0890	080	CA
80,0	94,0	+0,054/0	8,0	12,0	8,0	DWP	0800	0940	080	CA
85,0	99,0	+0,054/0	8,0	11,0	8,0	DWP	0850	0990	080	CA
90,0	104,0	+0,054/0	8,0	11,0	8,0	DWP	0900	1040	080	CA
95,0	109,0	+0,054/0	8,0	11,0	8,0	DWP	0950	1090	080	CA
100,0	114,0	+0,054/0	8,0	11,0	8,0	DWP	1000	1140	080	CA
105,0	121,0	+0,063/0	9,0	12,0	9,0	DWP	1050	1210	090	CA
110,0	126,0	+0,063/0	9,0	12,0	9,0	DWP	1100	1260	090	CA
115,0	131,0	+0,063/0	9,0	12,0	9,0	DWP	1150	1310	090	CA
120,0	136,0	+0,063/0	9,0	12,0	9,0	DWP	1200	1360	090	CA
130,0	146,0	+0,063/0	9,0	12,0	9,0	DWP	1300	1460	090	CA
140,0	160,0	+0,063/0	10,0	14,0	10,0	DWP	1400	1600	100	CA

Nota: altre dimensioni non a catalogo a richiesta. Consultare il nostro ufficio tecnico.

Remark: please contact our technical dept. for further dimensions not included in the catalogue.

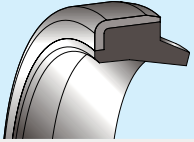

R09

RASCHIATORE CON GABBIA METALLICA TIPO R09

Descrizione

Il raschiatore R09 ha la funzione di pulire lo stelo al suo rientro e mantenere le impurità all'esterno. È composto da un'anima metallica rettificata all'esterno e incollata a un elemento raschiante in NBR. La cava che alloggia il raschiatore è aperta e ne facilita il montaggio.

Dati tecnici

Velocità: < 0,8 m/s
 Temperatura: da - 30° C a + 100 ° C con punte fino a 110° C.
 Fluidi: agenti atmosferici, acqua a temperatura inferiore a 60° C, oli a base minerale
 (v. tabella 3 a p. 14)

Materiale

Il materiale del raschiatore è in gomma nitrilica NBR 90 Shore A e anima in acciaio AISI 1010
 Codice materiale standard: NG

Montaggio

Il montaggio avviene in cava aperta. Togliere gli spigoli vivi e le bave per facilitare l'inserimento.

Attenzione: La cava dove alloggia il raschiatore deve essere in tolleranza di lavorazione come indicato nella tabella. Il mancato rispetto della misura della tolleranza può causare la fuoriuscita del raschiatore durante il movimento.

R09 TYPE WIPER WITH METAL CAGE

Description

The function of the R09 wiper is cleaning the rod while return into position, blocking external impurities. It is made up of an external, ground metal cage core part glued to a NBR element. The groove is open and makes easier the design of the seat.

Technical data

Speed: < 0.8 m/s
 Temperature: from - 30° C to + 100 ° C with peaks till 110° C.
 Fluids: atmospheric factors, water at a temperature below 60° C, mineral oils
 (see table 3, page 14)

Material

The wiper material is a nitrile rubber NBR 90 Shore A with steel core AISI 1010.
 Compound reference: NG

Assembling

The assembling is done in open groove. Remove flashes and cutting edges to allow better installation of the wiper.

Warning: The housing of the wiper must be within the machining tolerance as shown in the table. Not observed tolerances may cause the expulsion of the wiper during the operations.



R09

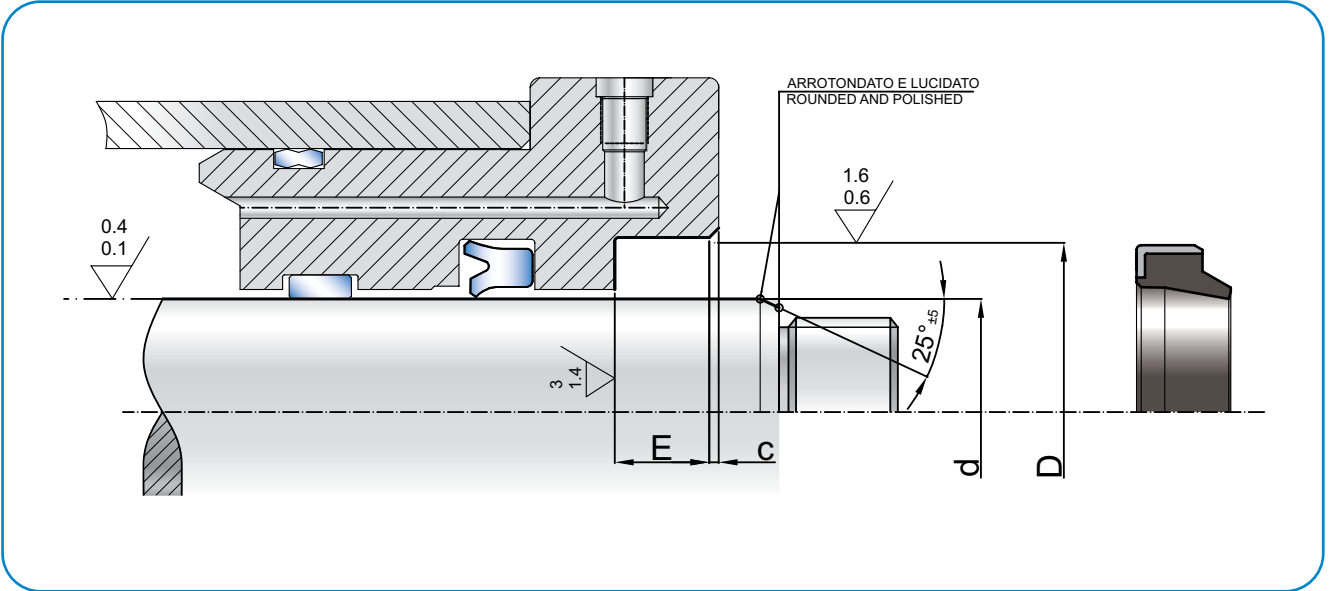
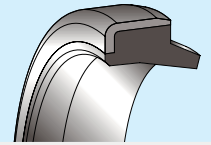

dh ₉	DH ₁₀	Toll.	E _{+0,2}	C	ART / ITEM
20,0	30,0	-0	4,0	0,8	R09 0200 0300 040 NG
20,0	30,0	+0,033	5,0	1,0	R09 0200 0300 050 NG
* 20,0	30,0		7,0	1,5	R09 0200 0300 070 NG
22,0	30,0	-0	4,0	0,8	R09 0220 0300 040 NG
22,0	32,0	+0,039	5,0	1,0	R09 0220 0320 050 NG
* 22,0	32,0		7,0	1,5	R09 0220 0320 070 NG
25,0	35,0	-0	5,0	1,5	R09 0250 0350 050 NG
* 25,0	35,0	+0,039	7,0	1,5	R09 0250 0350 070 NG
28,0	38,0		5,0	1,0	R09 0280 0350 050 NG
28,0	38,0	-0	7,0	1,5	R09 0280 0380 070 NG
30,0	40,0	+0,039	5,0	1,0	R09 0300 0400 050 NG
30,0	40,0		7,0	1,5	R09 0300 0400 070 NG
32,0	42,0	-0	5,0	1,0	R09 0320 0420 050 NG
32,0	42,0	+0,039	7,0	1,5	R09 0320 0420 070 NG
35,0	45,0		5,0	1,0	R09 0350 0450 050 NG
* 35,0	45,0	-0	7,0	1,5	R09 0350 0450 070 NG
36,0	46,0	+0,039	5,0	1,0	R09 0360 0460 050 NG
38,0	48,0		7,0	1,0	R09 0380 0480 070 NG
40,0	50,0	-0	5,0	1,0	R09 0400 0500 050 NG
* 40,0	50,0	+0,046	7,0	1,5	R09 0400 0500 070 NG
42,0	52,0		7,0	1,5	R09 0420 0520 070 NG

dh ₉	DH ₁₀	Toll.	E _{+0,2}	C	ART / ITEM
45,0	55,0	-0	7,0	1,5	R09 0450 0550 070 NG
50,0	56,0	+0,046	5,0	1,0	R09 0500 0560 050 NG
50,0	60,0		5,0	1,0	R09 0500 0600 050 NG
* 50,0	60,0		7,0	1,5	R09 0500 0600 070 NG
55,0	65,0	-0	7,0	1,5	R09 0550 0650 070 NG
* 56,0	66,0	+0,046	7,0	1,5	R09 0560 0660 070 NG
60,0	70,0		5,0	1,0	R09 0600 0700 050 NG
60,0	70,0	-0	7,0	1,5	R09 0600 0700 070 NG
65,0	75,0	0,046	7,0	1,5	R09 0650 0750 070 NG
* 70,0	80,0		7,0	1,5	R09 0700 0800 070 NG
75,0	85,0	-0	7,0	1,5	R09 0750 0850 070 NG
* 80,0	90,0	+0,054	7,0	1,5	R09 0800 0900 070 NG
85,0	95,0		7,0	1,5	R09 0850 0950 070 NG
* 90,0	100,0	-0	7,0	1,5	R09 0900 1000 070 NG
95,0	105,0	+0,054	7,0	1,5	R09 0950 1050 070 NG
100,0	110,0		7,0	1,5	R09 1000 1100 070 NG
110,0	120,0	-0	7,0	1,5	R09 1100 1200 070 NG
120,0	130,0	+0,063	7,0	1,5	R09 1200 1300 070 NG
140,0	155,0		9,0	1,5	R09 1400 1550 090 NG

Nota: altre dimensioni non a catalogo a richiesta. Consultare il nostro ufficio tecnico.

Remark: please contact our technical dept. for further dimensions not included in the catalogue.

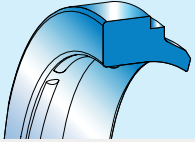

WWS

RASCHIATORE CON STEP TIPO WWS

Descrizione

A differenza di altri profili, il raschiatore tipo WWS è agganciato alla sede tramite un gradino sul lato statico. Questa struttura facilita il montaggio in automatico del particolare e semplifica l'esecuzione meccanica della sede.

I notches della base interna fungono da stabilizzatori e assicurano uno sfiato alla pressione che potrebbe crearsi per via di perdite tra guarnizione e raschiatore con conseguente espulsione di quest'ultimo dalla sede.

Dati tecnici

Velocità: < 0,8 m/s

Temperatura: da - 35° C a + 100 ° C con punte fino a 110° C.

Fluidi: agenti atmosferici, acqua a temperatura inferiore a 60° C, oli a base minerale
(v. tabella 3 a p. 14)

Materiale

Il materiale utilizzato è un poliuretano molto flessibile (anche a basse temperature) con un'alta resistenza all'abrasione.

Materiale standard poliuretano 90 Shore A (Bo) fino al diametro 35mm.

Per diametri maggiori il poliuretano 93 Shore A (Co).

Codice materiale per diam ≤ 35mm: Bo

Codice materiale per diam > 36mm: Co

Montaggio

La sede semiaperta facilita il montaggio.

Eliminare bave e spigoli taglienti nella sede.

Per ulteriori informazioni leggere le istruzioni a p. 63.

WWS TYPE WIPER WITH STEP

Description

The WWS scraper, unlike other profiles, has a step in the static side which hooks it to the housing.

This helps automated assembling and makes the mechanical construction of the groove extremely easy.

It presents notches in the wiper inner base having stabilisation effect, ensuring good ventilation.

This avoids extrusion problems.

Technical data

Speed: < 0.8 m/s

Temperature: from - 35° C to + 100 ° C with peaks till 110° C.

Fluids: atmospheric factors, water at a temperature below 60° C, mineral oils
(see table 3, page 14)

Material

The material used is a very flexible polyurethane, even at low temperatures, with a high abrasion resistance.

Standard polyurethane 90 Shore A up to diameter 35 mm (Bo).

For bigger dimensions standard polyurethane 93 Shore A (Co).

Compound reference diam ≤ 35mm: Bo

Compound reference diam > 36mm: Co

Assembling

The assembling is much easier since it can be done in semi-open groove.

Remove flashes an/or cutting edges in the housing.

For further information please refer to the installation instructions on page 63.



WWS

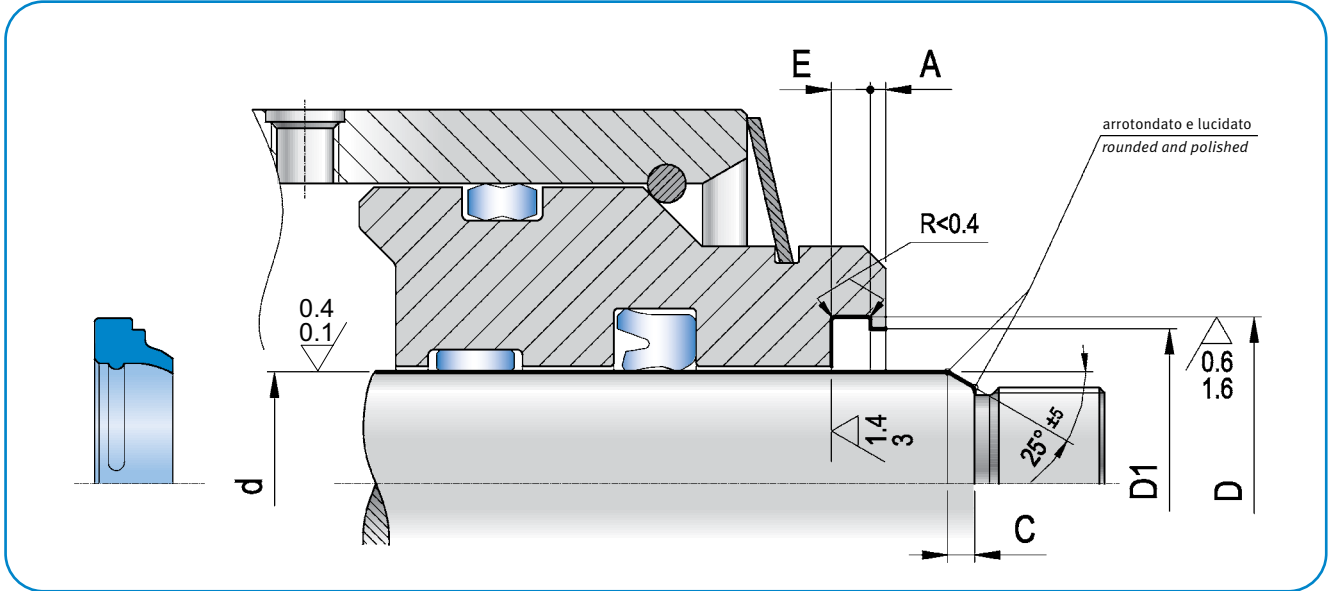
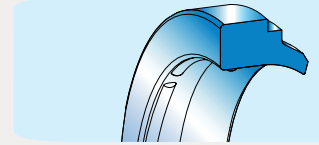

d_{h9}	D_{H10}	$E_{+0,2}$	$D_1 H_{11}$	$A_{min.}$	ART / ITEM
5,0	11,0	4,0	8,0	1,0	WWS 0050 0110 040 Bo
* 6,0	10,0	2,0	9,0	1,0	WWS 0060 0100 020 Bo
* 8,0	14,0	2,6	12,0	1,0	WWS 0080 0140 026 Bo
* 10,0	16,0	2,6	14,0	1,0	WWS 0100 0160 026 Bo
* 10,0	18,0	4,0	16,0	1,0	WWS 0100 0180 040 Bo
* 12,0	18,0	2,6	16,0	1,0	WWS 0120 0180 026 Bo
* 12,0	20,0	4,0	18,0	1,0	WWS 0120 0200 040 Bo
* 14,0	20,0	2,6	18,0	1,0	WWS 0140 0200 026 Bo
* 14,0	22,0	4,0	20,0	1,0	WWS 0140 0220 040 Bo
15,0	23,0	4,0	21,0	1,0	WWS 0150 0230 040 Bo
* 16,0	24,0	4,0	22,0	1,0	WWS 0160 0240 040 Bo
* 18,0	26,0	4,0	24,0	1,0	WWS 0180 0260 040 Bo
20,0	26,0	3,1	24,0	1,0	WWS 0200 0260 031 Bo
* 20,0	28,0	4,0	26,0	1,0	WWS 0200 0280 040 Bo
* 22,0	30,0	4,0	28,0	1,0	WWS 0220 0300 040 Bo
24,0	32,0	4,0	30,0	1,0	WWS 0240 0320 040 Bo
* 25,0	33,0	4,0	31,0	1,0	WWS 0250 0330 040 Bo
* 28,0	36,0	4,0	34,0	1,0	WWS 0280 0360 040 Bo
30,0	38,0	4,0	36,0	1,0	WWS 0300 0380 040 Bo
* 32,0	40,0	4,0	38,0	1,0	WWS 0320 0400 040 Bo
34,0	42,0	4,0	40,0	1,0	WWS 0340 0420 040 Bo
35,0	43,0	4,0	41,0	1,0	WWS 0350 0430 040 Bo
* 36,0	44,0	4,0	42,0	1,0	WWS 0360 0440 040 Co
38,0	46,0	4,0	44,0	1,0	WWS 0380 0460 040 Co
* 40,0	48,0	4,0	46,0	1,0	WWS 0400 0480 040 Co
42,0	50,0	4,0	48,0	1,0	WWS 0420 0500 040 Co
* 45,0	53,0	4,0	51,0	1,0	WWS 0450 0530 040 Co

d_{h9}	D_{H10}	$E_{+0,2}$	$D_1 H_{11}$	$A_{min.}$	ART / ITEM
* 50,0	58,0	4,0	56,0	1,0	WWS 0500 0580 040 Co
52,0	60,0	4,0	58,0	1,0	WWS 0520 0600 040 Co
55,0	63,0	4,0	61,0	1,0	WWS 0550 0630 040 Co
* 56,0	64,0	4,0	62,0	1,0	WWS 0560 0640 040 Co
60,0	68,0	4,0	66,0	1,0	WWS 0600 0680 040 Co
* 63,0	71,0	4,0	69,0	1,0	WWS 0630 0710 040 Co
63,5	71,5	4,0	69,5	1,0	WWS 0635 0715 040 Co
65,0	73,0	4,0	71,0	1,0	WWS 0650 0730 040 Co
* 70,0	78,0	4,0	76,0	1,0	WWS 0700 0780 040 Co
75,0	83,0	4,0	81,0	1,0	WWS 0750 0830 040 Co
* 80,0	88,0	4,0	86,0	1,0	WWS 0800 0880 040 Co
85,0	93,0	4,0	91,0	1,0	WWS 0850 0930 040 Co
* 90,0	98,0	4,0	96,0	1,0	WWS 0900 0980 040 Co
95,0	103,0	4,0	101,0	1,0	WWS 0950 1030 040 Co
* 100,0	108,0	4,0	106,0	1,0	WWS 1000 1080 040 Co
110,0	122,0	5,5	119,0	1,5	WWS 1100 1220 055 Co
120,0	132,0	5,5	129,0	1,5	WWS 1200 1320 055 Co
* 125,0	137,0	5,5	134,0	1,5	WWS 1250 1370 055 Co
* 140,0	152,0	5,5	149,0	1,5	WWS 1400 1520 055 Co
150,0	162,0	5,5	159,0	1,5	WWS 1500 1620 055 Co
* 160,0	172,0	5,5	169,0	1,5	WWS 1600 1720 055 Co
* 180,0	192,0	5,5	189,0	1,5	WWS 1800 1920 055 Co

* in conformità alle norme ISO 3320 – in accordance with ISO 3320 norms

Nota: altre dimensioni non a catalogo a richiesta. Consultare il nostro ufficio tecnico.

Remark: please contact our technical dept. for further dimensions not included in the catalogue.

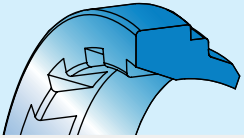

W W N

RASCHIATORE CON STEP TIPO WWN

Descrizione

Il raschiatore tipo WWN può considerarsi una evoluzione del tradizionale WWS.

Le tacche presenti hanno la funzione di scaricare la pressione residua formata tra la guarnizione e il raschiatore evitando l'espulsione di quest'ultimo. Utilizzato principalmente in applicazioni quali molle a gas.

Dati tecnici

Velocità: < 0,8 m/s

Temperatura: da -35° C a +100° C con punte fino a 110° C.

Fluidi: agenti atmosferici, acqua a temperatura inferiore a 60° C, oli a base minerale (v. tabella 3 a p. 14)

Materiale

Il materiale utilizzato è un poliuretano molto flessibile (anche a basse temperature) con un'alta resistenza all'abrasione.

Materiale standard poliuretano 90 Shore A (Bo) fino al diametro 35mm.

Per diametri maggiori il poliuretano 93 Shore A (Co).

Codice materiale per diam ≤ 35mm: Bo

Codice materiale per diam > 36mm: Co

Montaggio

La sede semiaperta facilita il montaggio.

Eliminare bave e spigoli taglienti nella sede.

Per ulteriori informazioni leggere le istruzioni a p. 63.

WWN TYPE WIPER WITH STEP

Description

The WWN type wiper is an evolution of the conventional WWS type.

A series of internal venting notches have the function of discharging the residual pressure build up formed between the rod seal and the wiper, thus avoiding the expulsion of the wiper due to pressure. Mainly used in applications such as gas springs.

Technical data

Speed: < 0.8 m/s

Temperature: from -35° C to +100° C with peaks till 110° C.

Fluids: atmospheric factors, water at a temperature below 60° C, mineral oils (see table 3, page 14)

Material

The material used is a very flexible polyurethane, even at low temperatures, with a high abrasion resistance.

Standard polyurethane 90 Shore A up to diameter 35 mm (Bo).

For larger dimensions standard polyurethane 93 Shore A (Co).

Compound reference diam ≤ 35mm: Bo

Compound reference diam > 36mm: Co

Assembling

The assembling is much easier since it can be done in semi-open groove.

Remove flashes an/or cutting edges in the housing.

For further information please refer to the installation instructions on page 63.



WWN

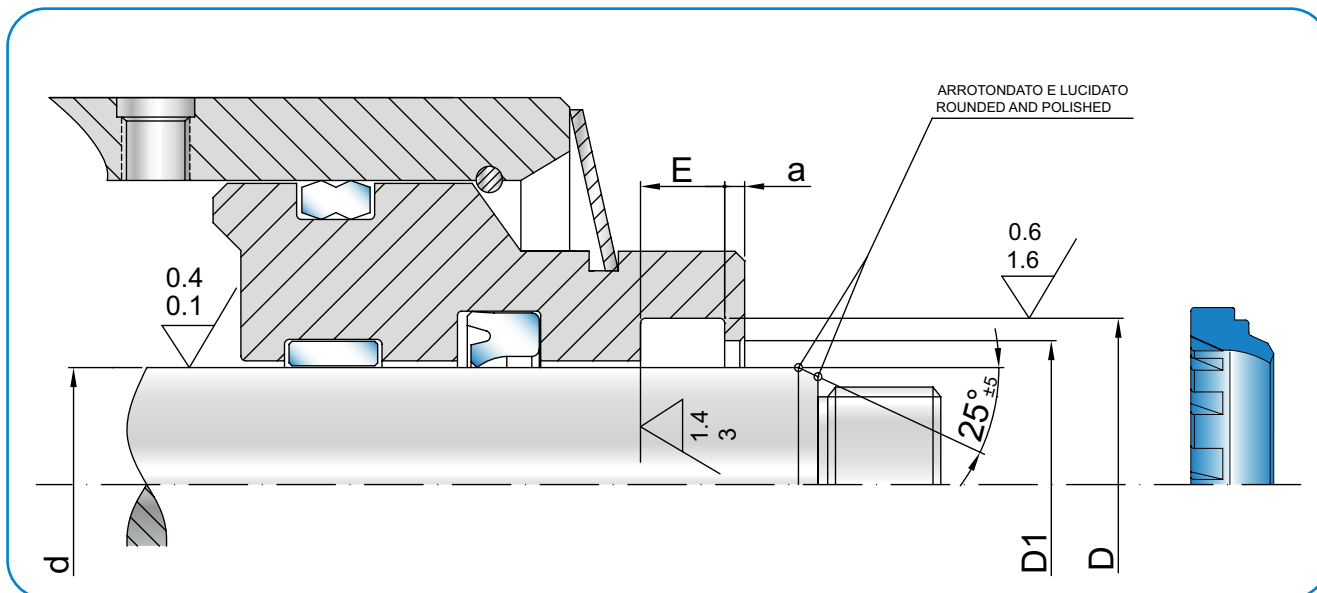

Oleodinamica
Hydraulic

dh ₉	D _{H10}	E _{+0,2}	D _{1 H11}	A _{min.}	ART / ITEM
5,0	11,0	4,0	8,0	1,0	WWN 0050 0110 040 Bo
* 6,0	10,0	2,0	9,0	1,0	WWN 0060 0100 020 Bo
* 8,0	14,0	2,6	12,0	1,0	WWN 0080 0140 026 Bo
* 10,0	16,0	2,6	14,0	1,0	WWN 0100 0160 026 Bo
* 10,0	18,0	4,0	16,0	1,0	WWN 0100 0180 040 Bo
11,0	15,0	2,0	14,0	1,0	WWN 0110 0150 020 Bo
* 12,0	18,0	2,6	16,0	1,0	WWN 0120 0180 026 Bo
* 12,0	20,0	4,0	18,0	1,0	WWN 0120 0200 040 Bo
14,0	18,0	2,0	17,0	1,0	WWN 0140 0180 020 Bo
* 14,0	20,0	2,6	18,0	1,0	WWN 0140 0200 026 Bo
* 14,0	22,0	4,0	20,0	1,0	WWN 0140 0220 040 Bo
15,0	19,0	2,0	18,0	1,0	WWN 0150 0190 020 Bo
15,0	23,0	4,0	21,0	1,0	WWN 0150 0230 040 Bo
16,0	20,0	2,0	19,0	1,0	WWN 0160 0200 020 Bo
* 16,0	24,0	4,0	22,0	1,0	WWN 0160 0240 040 Bo
* 18,0	26,0	4,0	24,0	1,0	WWN 0180 0260 040 Bo
20,0	24,0	2,0	23,0	1,0	WWN 0200 0240 020 Bo
* 20,0	28,0	4,0	26,0	1,0	WWN 0200 0280 040 Bo
* 22,0	30,0	4,0	28,0	1,0	WWN 0220 0300 040 Bo
24,0	32,0	4,0	30,0	1,0	WWN 0240 0320 040 Bo
* 25,0	31,0	2,6	29,0	1,0	WWN 0250 0310 026 Bo
* 25,0	33,0	4,0	31,0	1,0	WWN 0250 0330 040 Bo
28,0	34,0	2,6	32,0	1,0	WWN 0280 0340 026 Bo
* 28,0	36,0	4,0	34,0	1,0	WWN 0280 0360 040 Bo

dh ₉	D _{H10}	E _{+0,2}	D _{1 H11}	A _{min.}	ART / ITEM
30,0	38,0	4,0	36,0	1,0	WWN 0300 0380 040 Bo
* 32,0	40,0	4,0	38,0	1,0	WWN 0320 0400 040 Bo
34,0	42,0	4,0	40,0	1,0	WWN 0340 0420 040 Bo
35,0	43,0	4,0	41,0	1,0	WWN 0350 0430 040 Bo
36,0	42,0	2,6	40,0	1,0	WWN 0360 0420 026 Bo
* 36,0	44,0	4,0	42,0	1,0	WWN 0360 0440 040 Co
38,0	46,0	4,0	44,0	1,0	WWN 0380 0460 040 Co
* 40,0	48,0	4,0	46,0	1,0	WWN 0400 0480 040 Co
42,0	50,0	4,0	48,0	1,0	WWN 0420 0500 040 Co
* 45,0	53,0	4,0	51,0	1,0	WWN 0450 0530 040 Co
* 50,0	58,0	4,0	56,0	1,0	WWN 0500 0580 040 Co
52,0	60,0	4,0	58,0	1,0	WWN 0520 0600 040 Co
55,0	63,0	4,0	61,0	1,0	WWN 0550 0630 040 Co
* 56,0	64,0	4,0	62,0	1,0	WWN 0560 0640 040 Co
60,0	68,0	4,0	66,0	1,0	WWN 0600 0680 040 Co
* 63,0	71,0	4,0	69,0	1,0	WWN 0630 0710 040 Co
63,5	71,5	4,0	69,5	1,0	WWN 0635 0715 040 Co
65,0	73,0	4,0	71,0	1,0	WWN 0650 0730 040 Co
* 70,0	78,0	4,0	76,0	1,0	WWN 0700 0780 040 Co
75,0	83,0	4,0	81,0	1,0	WWN 0750 0830 040 Co
* 80,0	88,0	4,0	86,0	1,0	WWN 0800 0880 040 Co
85,0	93,0	4,0	91,0	1,0	WWN 0850 0930 040 Co
* 90,0	98,0	4,0	96,0	1,0	WWN 0900 0980 040 Co
* 100,0	108,0	4,0	106,0	1,0	WWN 1000 1080 040 Co

* in conformità alle norme ISO 3320 – in accordance with ISO 3320 norms

Nota: altre dimensioni non a catalogo a richiesta. Consultare il nostro ufficio tecnico.

Remark: please contact our technical dept. for further dimensions not included in the catalogue.

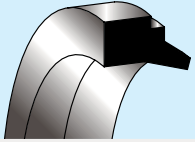

R08

RASCHIATORE CON STEP TIPO R08

Descrizione

Gli anelli raschiatori della serie Ro8 sono utilizzati per impedire l'ingresso di impurità all'interno di apparecchiature oleodinamiche e proteggere guarnizioni e parti metalliche che altrimenti potrebbero essere danneggiate. Rispetto alla serie Ro6, la Ro8 presenta un ulteriore gradino sulla superficie del diametro esterno che blocca, anche radialmente, la parte rigida del raschiatore elevando così le velocità di scorrimento.

Dati tecnici

Velocità: < 0,8 m/s

Temperatura: da -30° C a +100° C con punte fino a 110° C.

Fluidi: agenti atmosferici, acqua a temperatura inferiore a 60° C, oli a base minerale
(v. tabella 3 a p. 14)

Materiale

Il materiale standard utilizzato è NBR 90 Shore A. Per le elevate temperature (da -15°C a +200°C) si consiglia l'utilizzo di FPM 90 Shore A.

Montaggio

La sede semiaperta facilita il montaggio.
Eliminare bave e spigoli taglienti nella sede.
Per ulteriori informazioni leggere le istruzioni a p. 63.

R08 TYPE WIPER WITH STEP

Description

The Ro8 series of wiper rings are used to prevent the ingress of impurities in hydraulic equipment, thus securing the seals that the metal parts that might otherwise be damaged.

Compared to the type Ro6 presents a further step on the surface of the outer diameter which serves to lock the rigid part of the wiper also radially, thus allowing higher sliding speed.

Technical data

Speed: < 0.8 m/s

Temperature: from -30° C to +100° C with peaks till 110° C.

Fluids: atmospheric factors, water at a temperature below 60° C, mineral oils
(see table 3, page 14)

Material

the standard material used is NBR 90 Shore A.
For high temperatures (from -15 ° C to +200 ° C), we recommend the use of FPM 90 Shore A.

Assembling

The assembling is much easier since it can be done in semi-open groove.
Remove flashes an/or cutting edges in the housing.
For further information please refer to the installation instructions on page 63.



R08

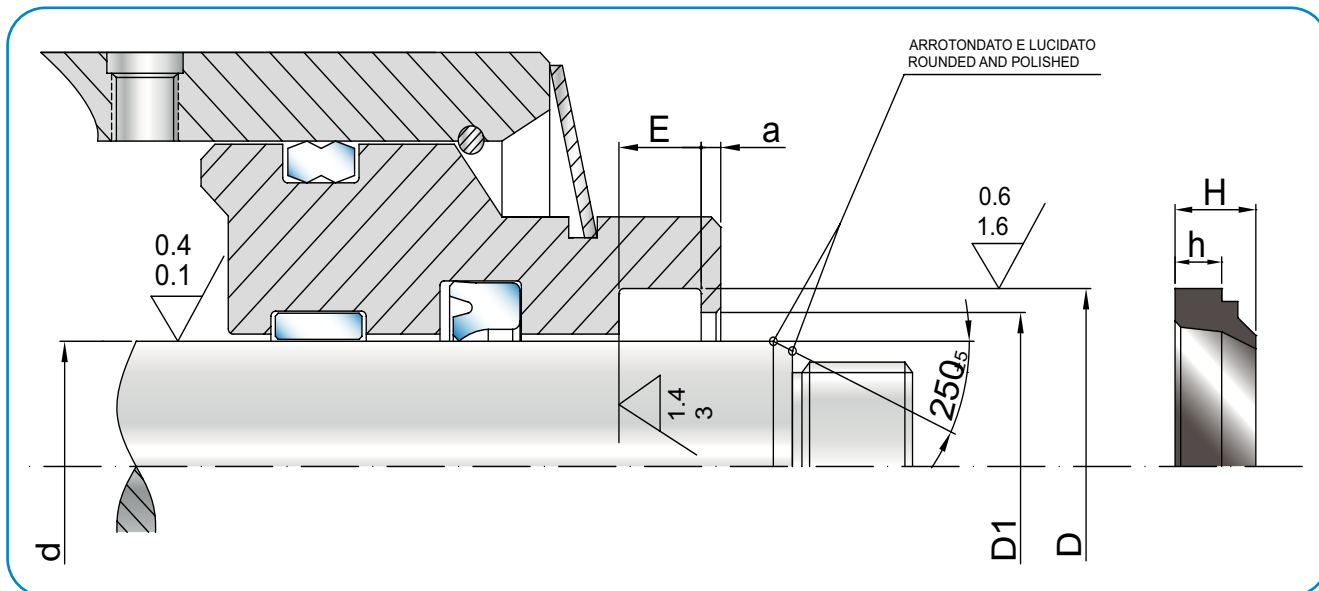
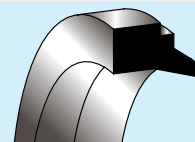

Oleodinamica
Hydraulic

d _{h9}	D _{H10}	D1	E _{+0,2}	H	a	ART / ITEM
4	12	10	4,0	7	1,0	Ro8 412
8	16	14	4,0	7	1,0	Ro8 816
10	18	16	4,0	7	1,0	Ro8 1018
12	20	18	4,0	7	1,0	Ro8 1220
14	22	20	4,0	7	1,0	Ro8 1422
15	23	21	4,0	7	1,0	Ro8 1523
16	24	22	4,0	7	1,0	Ro8 1624
17	25	23	4,0	7	1,0	Ro8 1725
18	26	24	4,0	7	1,0	Ro8 1826
20	28	26	4,0	7	1,0	Ro8 2028
22	30	29	4,0	7	1,0	Ro8 2230
23	31	29	4,0	7	1,0	Ro8 2331
24	32	30	4,0	7	1,0	Ro8 2432
25	33	31	4,0	7	1,0	Ro8 2533
26	34	32	4,0	7	1,0	Ro8 2634
28	36	34	4,0	7	1,0	Ro8 2836
30	38	36	4,0	7	1,0	Ro8 3038
32	40	38	4,0	7	1,0	Ro8 3240
33	41	39	4,0	7	1,0	Ro8 3341
34	42	40	4,0	7	1,0	Ro8 3442
35	43	41	4,0	7	1,0	Ro8 3543
36	44	42	4,0	7	1,0	Ro8 3644
38	46	44	4,0	7	1,0	Ro8 3846
40	48	46	4,0	7	1,0	Ro8 4048
41	49	47	4,0	7	1,0	Ro8 4149
42	50	48	4,0	7	1,0	Ro8 4250
44	52	50	4,0	7	1,0	Ro8 4452

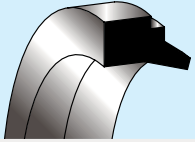

RO8

d _{h9}	D _{H10}	D1	E _{+0,2}	H	a	ART / ITEM
45	53	51	4,0	7	1,0	Ro8 4553
46	54	52	4,0	7	1,0	Ro8 4654
47	55	53	4,0	7	1,0	Ro8 4755
48	56	54	4,0	7	1,0	Ro8 4856
50	58	56	4,0	7	1,0	Ro8 5058
51	59	57	4,0	7	1,0	Ro8 5159
52	60	58	4,0	7	1,0	Ro8 5260
53	61	59	4,0	7	1,0	Ro8 5361
54	62	60	4,0	7	1,0	Ro8 5462
55	63	61	4,0	7	1,0	Ro8 5563
56	64	62	4,0	7	1,0	Ro8 5664
58	66	64	4,0	7	1,0	Ro8 5866
60	68	66	4,0	7	1,0	Ro8 6068
62	70	68	4,0	7	1,0	Ro8 6270
63	71	69	4,0	7	1,0	Ro8 6371
64	72	70	4,0	7	1,0	Ro8 6472
65	73	71	4,0	7	1,0	Ro8 6573
66	74	72	4,0	7	1,0	Ro8 6674
67	75	73	4,0	7	1,0	Ro8 6775
68	76	74	4,0	7	1,0	Ro8 6876
70	78	76	4,0	7	1,0	Ro8 7078
72	80	78	4,0	7	1,0	Ro8 7280
73	81	79	4,0	7	1,0	Ro8 7381
75	83	81	4,0	7	1,0	Ro8 7583
78	86	84	4,0	7	1,0	Ro8 7886
80	88	86	4,0	7	1,0	Ro8 8088
82	90	88	4,0	7	1,0	Ro8 8290
83	91	89	4,0	7	1,0	Ro8 8391
85	93	91	4,0	7	1,0	Ro8 8593
86	94	92	4,0	7	1,0	Ro8 8694
88	96	94	4,0	7	1,0	Ro8 8896
90	98	96	4,0	7	1,0	Ro8 9098
93	101	99	4,0	7	1,0	Ro8 93101
95	103	101	4,0	7	1,5	Ro8 95103
100	108	106	4,0	7	1,5	Ro8 100108
102	114	111	5,5	10	1,5	Ro8 102114
105	117	114	5,5	10	1,5	Ro8 105117
106	118	115	5,5	10	1,5	Ro8 106118
110	118	116	4,0	7	1,5	Ro8 110118
110	122	119	5,5	10	1,5	Ro8 110122
112	124	121	5,5	10	1,5	Ro8 112124
115	127	124	5,5	10	1,5	Ro8 115127
118	130	127	5,5	10	1,5	Ro8 118130
120	132	129	5,5	10	1,5	Ro8 120132
125	137	134	5,5	10	1,5	Ro8 125137



R08

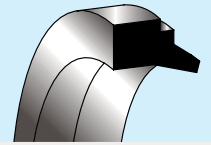

d _{h9}	D _{H10}	D1	E _{+0,2}	H	a	ART / ITEM
128	140	137	5,5	10	1,5	Ro8 128140
130	142	139	5,5	10	1,5	Ro8 130142
135	147	144	5,5	10	1,5	Ro8 135147
140	152	149	5,5	10	1,5	Ro8 140152
142	154	151	5,5	10	1,5	Ro8 142154
145	157	154	5,5	10	1,5	Ro8 145157
150	162	159	5,5	10	1,5	Ro8 150162
152	164	161	5,5	10	1,5	Ro8 152164
154	166	163	5,5	10	1,5	Ro8 154166
155	167	164	5,5	10	1,5	Ro8 155167
160	172	169	5,5	10	1,5	Ro8 160172
165	177	174	5,5	10	1,5	Ro8 165177
166	178	175	5,5	10	1,5	Ro8 166178
170	182	179	5,5	10	1,5	Ro8 170182
175	187	184	5,5	10	1,5	Ro8 175187
180	192	189	5,5	10	1,5	Ro8 180192
190	202	199	5,5	10	2,0	Ro8 190202
200	212	209	5,5	10	2,0	Ro8 200212
210	225	221	6,5	13	2,0	Ro8 210225
220	235	231	6,5	13	2,0	Ro8 220235
235	250	246	6,5	13	2,0	Ro8 235250
238	253	249	6,5	13	2,0	Ro8 238253
240	255	251	6,5	13	2,0	Ro8 240255
250	265	261	6,5	13	2,0	Ro8 250265
300	315	311	6,5	13	2,0	Ro8 300315
310	325	321	6,5	13	2,0	Ro8 310325
340	355	351	6,5	13	2,0	Ro8 340355
365	380	376	6,5	13	2,0	Ro8 365380
450	465	461	6,5	13	2,0	Ro8 450465

Nota: altre dimensioni non a catalogo a richiesta. Consultare il nostro ufficio tecnico.

Remark: please contact our technical dept. for further dimensions not included in the catalogue.

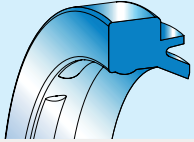

WAT

RASCHIATORE ANTI-RIBALTAMENTO TIPO WAT

Descrizione

Dotato di uno speciale profilo, il raschiatore tipo WAT ha la possibilità di autoallinearsi quando lo stelo è soggetto a forti disallineamenti durante l'esercizio. Presenta due labbri che lo rendono simile a una tenuta: il labbro dinamico raschiante più lungo e molto flessibile, il labbro statico più corto che, appoggiandosi sul gradino trattenitore, evita l'entrata delle impurità dall'esterno.

Dati tecnici

Velocità: < 0,8 m/s

Temperatura: da -35°C a $+100^{\circ}\text{C}$ con punte fino a 110°C .

Fluidi: agenti atmosferici, acqua a temperatura inferiore a 60°C , oli a base minerale
(v. tabella 3 a p. 14)

Materiale

I materiali utilizzati sono poliuretani con alto modulo elastico resistenti ad agenti atmosferici e abrasione. Il materiale standard è di durezza 93 Shore A ± 2 . In alternativa, in presenza di condizioni gravose in ambienti molto inquinati, sono utilizzabili poliuretani di durezza superiore. In questo caso consultare il nostro ufficio tecnico.
Codice materiale: Co

Montaggio

La sede semiaperta semplifica il montaggio. Eliminare gli spigoli taglienti e le bave nella sede. Per ulteriori informazioni leggere le istruzioni a p. 63.

WAT TYPE NO-TWISTING WIPER

Description

The WAT wiper can be self-aligned in case of rod misalignment during operations, thanks to its special profile and design. It presents two lips and it's similar to a seal: the scraping lip is longer very flexible and dynamic; the static lip is shorter and stops the impurity sticking to the blocking step.

Technical data

Speed: < 0.8 m/s

Temperature: from -35°C to $+100^{\circ}\text{C}$ with peaks till 110°C .

Fluids: atmospheric factors, water at a temperature below 60°C , mineral oils
(see table 3, page 14)

Material

The proposed material is a "Co" type polyurethane, with high elasticity modulus, low compression-set and high abrasion resistance. The hardness is 93 Shore A ± 2 .
Compound reference: Co
It is also possible to use harder polyurethanes for heavy polluted environments.
In case please contact our technical department.

Assembling

The assembling is extremely easy because of the semi-open groove. Remove flashes an/or cutting edges in the housing. For further information please refer to the installation instructions on page 63.



WAT

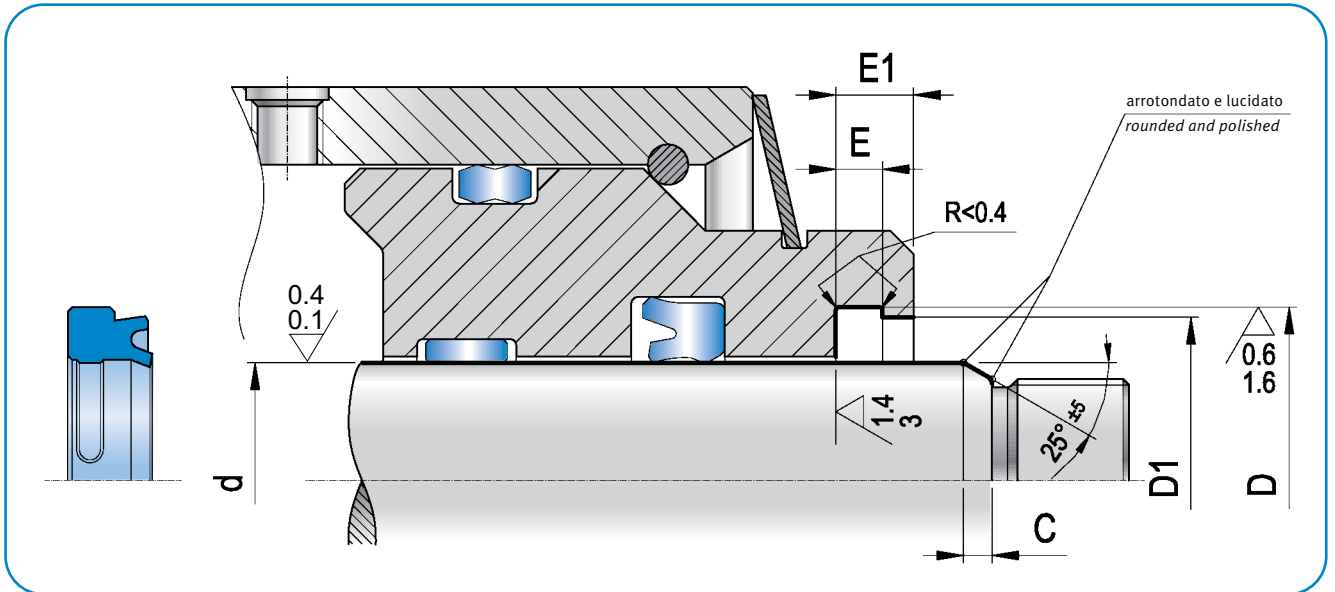

dh ₉	DH ₁₀	D ₁ H ₁₁	E _{+0,2}	E _{1 +0,2}	ART / ITEM
12,0	20,0	17,5	5,0	7,0	WAT 0120 0200 050 Co
16,0	24,0	21,5	5,0	7,0	WAT 0160 0240 050 Co
18,0	26,0	23,5	5,0	7,0	WAT 0180 0260 050 Co
20,0	28,0	25,5	5,0	7,0	WAT 0200 0280 050 Co
22,0	30,0	27,5	5,0	7,0	WAT 0220 0300 050 Co
25,0	33,0	30,5	5,0	7,0	WAT 0250 0330 050 Co
28,0	36,0	33,5	5,0	7,0	WAT 0280 0360 050 Co
32,0	40,0	37,5	5,0	7,0	WAT 0320 0400 050 Co
36,0	44,0	41,5	5,0	7,0	WAT 0360 0440 050 Co
40,0	48,0	45,5	5,0	7,0	WAT 0400 0480 050 Co
45,0	53,0	50,5	5,0	7,0	WAT 0450 0530 050 Co
50,0	58,0	55,5	5,0	7,0	WAT 0500 0580 050 Co
56,0	66,0	63,0	6,3	8,3	WAT 0560 0660 063 Co
60,0	68,0	65,5	5,0	7,0	WAT 0600 0680 050 CO
63,0	73,0	70,0	6,3	8,3	WAT 0630 0730 063 Co

dh ₉	DH ₁₀	D ₁ H ₁₁	E _{+0,2}	E _{1 +0,2}	ART / ITEM
70,0	80,0	77,0	6,3	8,3	WAT 0700 0800 063 Co
80,0	90,0	87,0	6,3	8,3	WAT 0800 0900 063 Co
90,0	100,0	97,0	6,3	8,3	WAT 0900 1000 063 Co
100,0	115,0	110,0	9,5	12,0	WAT 1000 1150 095 Co
110,0	122,0	119,0	5,5	7,0	WAT 1100 1220 055 CO
110,0	125,0	120,0	9,5	12,0	WAT 1100 1250 095 CO
115,0	127,0	124,0	5,5	7,0	WAT 1150 1270 055 CO
120,0	132,0	129,0	5,5	7,0	WAT 1200 1320 055 CO
125,0	137,0	134,0	5,5	7,0	WAT 1250 1370 055 CO
125,0	140,0	135,0	9,5	12,0	WAT 1250 1400 095 CO

Nota: altre dimensioni non a catalogo a richiesta. Consultare il nostro ufficio tecnico.

Remark: please contact our technical dept. for further dimensions not included in the catalogue.

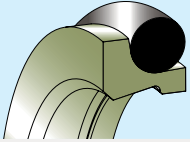

TRD

ANELLO RASCHIATORE TIPO TRD

Descrizione

I raschiatori tipo TRD sono composti da un elemento in PTFE + o-ring che svolge tenuta nella parte statica e contemporaneamente svolge un effetto energizzante sul raschiatore in assenza di pressione. Il TRD ha un effetto raschiante della parte esterna del cilindro e trattiene il film di olio residuo dal lato interno dello stelo. Con una tenuta adeguata permette di lavorare con ritorno idrodinamico nel cilindro.

Dati tecnici

Velocità: < 15 m/s

Temperatura: da -30°C a + 100° C per il tipo standard con O-Ring in nitrile.

Con punte fino a 120°C per periodi brevi e da -15°C a + 200° C per il tipo con o-ring in FKM.

Materiale

PTFE caricato a bronzo per il tipo standard e o-ring in nitrile.

Codice materiale: TN

Montaggio

Il montaggio è semplificato perché effettuato in cava semiaperta.

- Inserire l'o-ring nella sede
- inserire l'elemento in PTFE
- eliminare gli spigoli vivi e le bave nella sede.

Per ulteriori informazioni leggere le istruzioni a p. 64.

TRD TYPE WIPER RING

Description

The TRD wipers are made of a PTFE element and an O-Ring having a sealing effect in the static part and, at the same time has an energizing effect on wiper in the absence of pressure.

The TRD also has a scraping effect on the outside of the Cylinder and maintains a residual oil film on the internal part of the rod.

Used with proper sealing, allows the hydrodynamic return in the cylinder.

Technical data

Speed: < 15 m/s

Temperature: from - 30° C to + 100° C for the standard type with nitrile O-Ring.

Short peaks till +120° C
from -15°C to +200°C with FKM o-rings

Material

Bronze-filled PTFE for the standard type, and nitrile rubber NBR for the O-Ring.

Compound reference: TN

Assembling

Easy assembling in semi-open groove.

- The O-Rings have to be fitted first into the groove
- then the PTFE element
- remove flashes and/or cutting edges in the groove.

For further information please refer to the installation instructions on page 64.



TRD

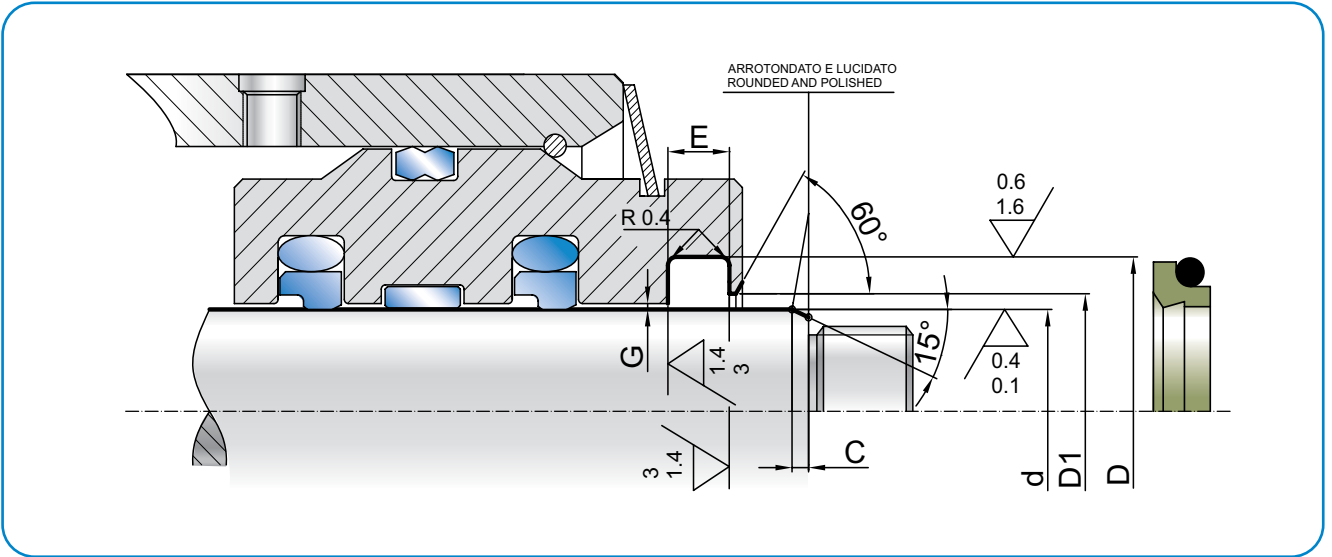
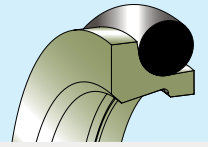

d_{f8}	D_{H9}	$E_{+0,2}$	O-	C	D_3	ART / ITEM
4,0	8,8	3,7	009	5,0	5,5	TRD 0040 0088 037 TN
5,0	9,8	3,7	010	5,0	6,5	TRD 0050 0980 037 TN
7,0	11,8	3,7	011	5,0	8,5	TRD 0070 011 037 TN
8,0	12,8	3,7	012	5,0	9,5	TRD 0080 0128 037 TN
10,0	14,8	3,7	013	5,0	11,5	TRD 0100 0148 037 TN
12,0	18,8	5,0	113	5,0	13,5	TRD 0120 0188 050 TN
14,0	20,8	5,0	114	5,0	15,5	TRD 0140 0208 050 TN
15,0	21,8	5,0	115	5,0	16,5	TRD 0150 0218 050 TN
16,0	22,8	5,0	116	5,0	17,5	TRD 0160 0228 050 TN
18,0	24,8	5,0	117	5,0	19,5	TRD 0180 0248 050 TN
20,0	26,8	5,0	118	5,0	21,5	TRD 0200 0268 050 TN
24,0	30,8	5,0	120	5,0	25,5	TRD 0240 0308 050 TN
25,0	31,8	5,0	121	5,0	26,5	TRD 0250 0318 050 TN
26,0	32,8	5,0	122	5,0	27,5	TRD 0260 0328 050 TN
28,0	34,8	5,0	123	5,0	29,5	TRD 0280 0348 050 TN
30,0	36,8	5,0	124	5,0	31,5	TRD 0300 0368 050 TN
32,0	38,8	5,0	126	5,0	33,5	TRD 0320 0388 050 TN
35,0	41,8	5,0	127	5,0	36,5	TRD 0350 0418 050 TN
37,0	43,8	5,0	129	5,0	38,5	TRD 0370 0438 050 TN
38,0	44,8	5,0	130	5,0	39,5	TRD 0380 0448 050 TN
40,0	46,8	5,0	131	5,0	41,5	TRD 0400 0468 050 TN
42,0	48,8	5,0	132	5,0	43,5	TRD 0420 0488 050 TN
45,0	51,8	5,0	134	5,0	46,5	TRD 0450 0518 050 TN
48,0	54,8	5,0	136	5,0	49,5	TRD 0480 0548 050 TN
50,0	56,8	5,0	137	5,0	51,5	TRD 0500 0568 050 TN
52,0	58,8	5,0	138	5,0	53,5	TRD 0520 0588 050 TN
55,0	61,8	5,0	140	5,0	56,5	TRD 0550 0618 050 TN
58,0	64,8	5,0	142	5,0	59,5	TRD 0580 0648 050 TN
60,0	66,8	5,0	143	5,0	61,5	TRD 0600 0668 050 TN
65,0	73,8	6,0	231	5,0	66,5	TRD 0650 0738 060 TN

d_{f8}	D_{H9}	$E_{+0,2}$	O-	C	D_3	ART / ITEM
70,0	78,8	6,0	233	5,0	71,5	TRD 0700 0788 060 TN
75,0	83,8	6,0	234	5,0	76,5	TRD 0750 0838 060 TN
80,0	88,8	6,0	236	5,0	81,5	TRD 0800 0888 060 TN
85,0	93,8	6,0	237	5,0	86,5	TRD 0850 0938 060 TN
90,0	98,8	6,0	239	5,0	91,5	TRD 0900 0988 060 TN
95,0	103,8	6,0	241	7,0	96,5	TRD 0950 1038 060 TN
100,0	108,8	6,0	242	7,0	101,5	TRD 1000 1088 060 TN
110,0	118,8	6,0	245	7,0	111,5	TRD 1100 1188 060 TN
120,0	128,8	6,0	249	7,0	121,5	TRD 1200 1288 060 TN
125,0	133,8	6,0	250	7,0	125,5	TRD 1250 1338 060 TN
130,0	138,8	6,0	252	7,0	131,5	TRD 1300 1388 060 TN
135,0	143,8	6,0	254	7,0	136,5	WAB 1350 1438 060 TN
140,0	148,8	6,0	255	7,0	141,5	TRD 1400 1488 060 TN
150,0	158,8	6,0	258	7,0	151,5	TRD 1500 1588 060 TN
155,0	163,8	6,0	259	7,0	156,5	TRD 1550 1638 060 TN
160,0	168,8	6,0	260	7,0	161,5	TRD 1600 1688 060 TN
170,0	178,8	6,0	261	7,0	171,5	TRD 1700 1788 060 TN
175,0	183,8	6,0	262	7,0	176,5	TRD 1750 1838 060 TN
180,0	188,8	6,0	263	7,0	181,5	TRD 1800 1888 060 TN
185,0	193,8	6,0	263	7,0	186,5	TRD 1850 1938 060 TN
190,0	198,8	6,0	264	7,0	191,5	TRD 1900 1988 060 TN
195,0	203,8	6,0	265	7,0	196,5	TRD 1950 2038 060 TN
200,0	208,8	6,0	266	10,0	201,5	TRD 2000 2088 060 TN
210,0	218,8	6,0	267	10,0	211,5	TRD 2100 2188 060 TN
220,0	228,8	6,0	269	10,0	221,5	TRD 2200 2288 060 TN
225,0	233,8	6,0	270	10,0	226,5	TRD 2250 2338 060 TN
230,0	238,8	6,0	271	10,0	231,5	TRD 2300 2388 060 TN
240,0	248,8	6,0	272	10,0	241,5	TRD 2400 2488 060 TN
250,0	258,8	6,0	274	10,0	251,5	TRD 2500 2588 060 TN
260,0	272,2	8,4	378	10,0	262,0	TRD 2600 2722 084 TN

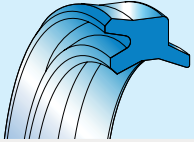

WED

RASCHIATORE BIDIREZIONALE TIPO WED

Descrizione

Il raschiatore bidirezionale tipo WED presenta il profilo combinato di un raschiatore e una guarnizione con un labbro raschiante nella parte esterna e un labbro di tenuta in quella interna. Ha le dimensioni intercambiabili con le sedi dei raschiatori più utilizzati. Il labbro che agisce come raschiatore è molto flessibile e si adatta ai disallineamenti dello stelo mentre quello sulla parte di tenuta è più robusto e allungato, proprio per garantire la tenuta e portare nel cilindro il film di olio che si crea sullo stelo.

Dati tecnici

Velocità: < 0,8 m/s
 Temperatura: da - 35° C a + 100 ° C con punte fino a 110° C.
 Fluidi: agenti atmosferici, acqua a temperatura inferiore a 60° C, oli a base minerale
 (v. tabella 3 a p. 14)

Materiale

I materiali utilizzati sono poliuretani con alto modulo elastico resistenti all'abrasione e agli agenti atmosferici. Il materiale standard è di durezza 93 Shore A. In alternativa, in presenza di condizioni gravose in ambienti molto inquinati, sono utilizzabili poliuretani di durezza superiore. In questo caso consultare il nostro ufficio tecnico.

Codice materiale: Co

Montaggio

Il montaggio, molto semplice, è in sede semiaperta. Eliminare bave e spigoli taglienti nella sede per non danneggiare la tenuta.
 Per ulteriori informazioni leggere le istruzioni a p. 63.

WED TYPE DOUBLE ACTING WIPER

Description

The WED bidirectional scraper has a combined scraper profile where the seal is provided with a scraping lip on the outside and a sealing lip on the inside.

The dimensions are interchangeable with normal scraper housings.

The scraping lip is very flexible and it compensates misalignments of the rod. The sealing side has a stronger and longer lip to ensure the sealing performance and to help the oil film remaining on the rod to go back into the cylinder.

Technical data

Speed: < 0.8 m/s
 Temperature: from - 35° C to + 100 ° C with peaks till 110° C.
 Fluids: atmospheric factors, water at a temperature below 60° C, mineral oils
 (see table 3, page 14)

Material

The proposed material is a "Co" type polyurethane, with high elasticity modulus, low compression-set and high abrasion resistance.

The hardness is 93 Shore A ± 2.

Compound reference: Co

It is also possible to use harder polyurethanes for heavy polluted environments.

In case please contact our technical department.

Assembling

The assembling is extremely easy because of the semi-open groove.

Remove flashes and/or cutting edges in the housing.

For further information please refer to the installation instructions on page 63.



WED

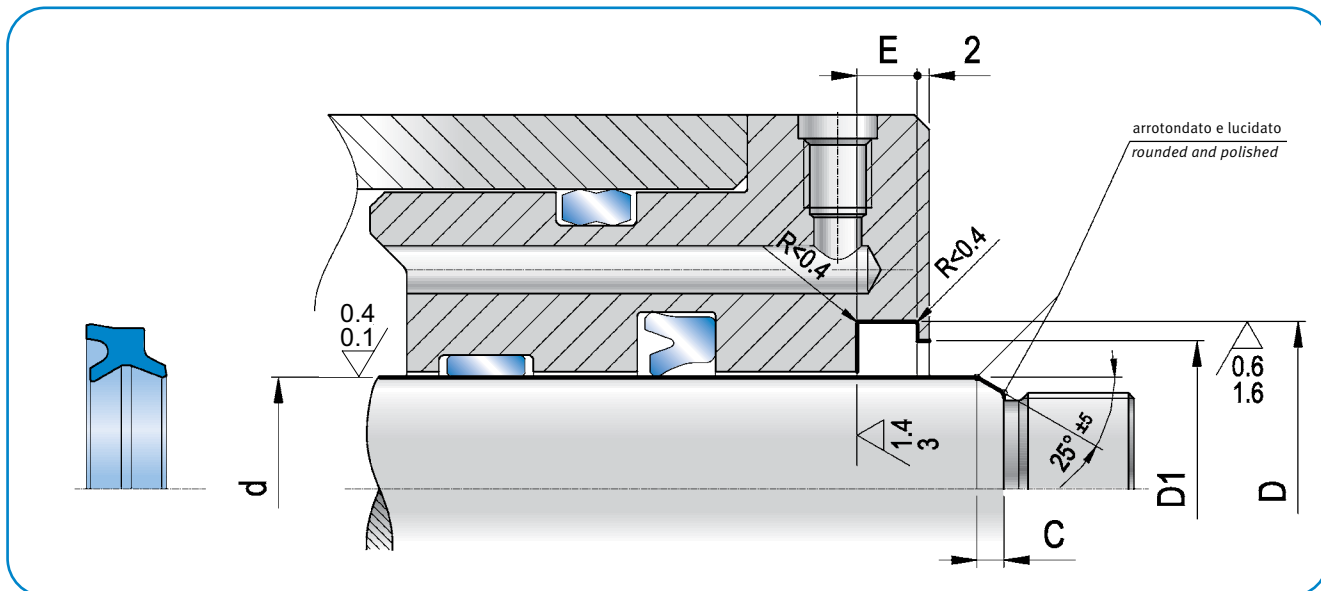
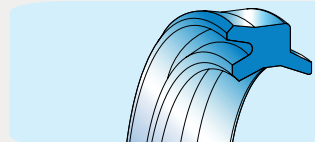

Oleodinamica
Hydraulic

	d_{H9}	D_{H10}	$E_{+0,2}$	$D_{10/+0,2}$	C	ART / ITEM
	6,0	11,0	3,5	8,5	>3,5	WED 0060 0110 035 Co
	8,0	13,0	3,5	10,5	>3,5	WED 0080 0130 035 Co
	10,0	16,0	4,0	13,0	>3,5	WED 0100 0160 040 Co
*	12,0	18,0	4,0	14,5	>3,5	WED 0120 0180 040 Co
	12,0	18,6	3,8	15,0	>3,5	WED 0120 0186 038 Co
*	14,0	20,0	4,0	16,5	>3,5	WED 0140 0200 040 Co
	14,0	20,6	3,8	17,0	>3,5	WED 0140 0206 038 Co
	14,0	22,0	6,0	18,5	>3,5	WED 0140 0220 060 Co
	16,0	22,0	4,0	18,5	>3,5	WED 0160 0220 040 Co
*	18,0	24,0	4,0	20,5	>3,5	WED 0180 0240 040 Co
	18,0	24,6	3,8	21,0	>3,5	WED 0180 0246 038 Co
	19,0	25,4	4,0	22,0	>3,5	WED 0190 0254 040 Co
	20,0	26,0	4,0	22,5	>3,5	WED 0200 0260 040 Co
	20,0	28,6	5,3	23,0	>3,5	WED 0200 0286 053 Co
*	22,0	28,0	4,0	24,5	>3,5	WED 0220 0280 040 Co
	22,0	30,6	5,3	25,0	>3,5	WED 0220 0306 053 Co
	24,0	32,6	5,3	27,0	>3,5	WED 0240 0326 053 Co
	25,0	31,0	4,0	27,5	>3,5	WED 0250 0310 040 Co
	25,0	33,6	5,3	28,0	>3,5	WED 0250 0336 053 Co
*	28,0	36,0	5,0	31,0	>3,5	WED 0280 0360 050 Co
	28,0	36,6	5,3	31,0	>3,5	WED 0280 0366 053 Co
	30,0	38,0	5,0	33,0	>3,5	WED 0300 0380 050 Co
	30,0	38,6	5,3	33,0	>3,5	WED 0300 0386 053 Co
	32,0	40,0	5,0	35,0	>3,5	WED 0320 0400 050 Co
	32,0	40,6	5,3	35,0	>3,5	WED 0320 0406 053 Co
	35,0	43,0	5,0	38,0	>3,5	WED 0350 0430 050 Co
	35,0	43,0	6,0	38,0	>3,5	WED 0350 0430 060 Co

* in conformità alle norme ISO 6195 – in accordance with ISO 6195 norm

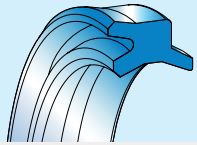

WED

	d_{hg}	D_{H10}	$E_{+0,2}$	$D_{1\ 0/+0,2}$	C	ART / ITEM
	35,0	43,6	5,3	38,0	> 3,5	WED 0350 0436 053 Co
	35,0	45,0	5,0	38,0	> 4,0	WED 0350 0450 050 CO
*	36,0	44,0	5,0	39,0	> 3,5	WED 0360 0440 050 Co
	36,0	44,6	5,3	39,0	> 3,5	WED 0360 0446 053 Co
	38,0	46,0	5,0	41,0	> 3,5	WED 0380 0460 050 CO
	40,0	48,0	5,0	43,0	> 4,0	WED 0400 0480 050 Co
	40,0	48,0	6,0	43,0	> 4,0	WED 0400 0480 060 Co
	40,0	48,6	5,3	43,0	> 4,0	WED 0400 0486 053 Co
	42,0	50,0	5,0	45,0	> 3,5	WED 0420 0500 050 CO
	42,0	50,0	6,0	45,0	> 3,5	WED 0420 0500 060 CO
*	45,0	53,0	5,0	48,0	> 4,0	WED 0450 0530 050 Co
	45,0	53,0	6,0	48,0	> 4,0	WED 0450 0530 060 Co
	45,0	53,6	5,3	48,0	> 4,0	WED 0450 0536 053 Co
	50,0	58,0	5,0	53,0	> 4,0	WED 0500 0580 050 Co
	50,0	58,0	6,0	53,0	> 4,0	WED 0500 0580 060 Co
	50,0	58,6	5,3	53,0	> 4,0	WED 0500 0586 053 Co
	50,0	60,0	6,0	53,0	> 4,0	WED 0500 0600 060 CO
	55,0	63,6	5,3	58,0	> 4,0	WED 0550 0636 053 Co
	55,0	65,0	6,0	58,0	> 4,0	WED 0550 0650 060 Co
	56,0	64,6	5,3	59,0	> 4,0	WED 0560 0646 053 Co
*	56,0	66,0	6,0	59,0	> 4,0	WED 0560 0660 060 Co
	58,0	68,0	6,0	61,0	> 4,0	WED 0580 0680 060 Co
	60,0	68,6	5,3	63,0	> 4,0	WED 0600 0686 053 Co
	60,0	70,0	6,0	63,0	> 4,0	WED 0600 0700 060 Co
	63,0	71,6	5,3	66,0	> 4,0	WED 0630 0716 053 Co
	63,0	73,0	6,0	66,0	> 4,0	WED 0630 0730 060 Co
	65,0	73,6	5,3	68,0	> 4,0	WED 0650 0736 053 Co
	65,0	75,0	6,0	68,0	> 4,0	WED 0650 0750 060 Co
	67,0	77,0	6,0	70,0	> 4,0	WED 0670 0770 060 CO
	70,0	78,6	5,3	73,0	> 4,0	WED 0700 0786 053 Co
*	70,0	80,0	6,0	73,0	> 4,0	WED 0700 0800 060 Co
	75,0	83,6	5,3	78,0	> 4,0	WED 0750 0836 053 Co
	75,0	85,0	6,0	78,0	> 4,0	WED 0750 0850 060 Co
	78,0	88,0	6,0	81,0	> 4,0	WED 0780 0880 060 Co
	80,0	88,6	5,3	83,0	> 4,0	WED 0800 0886 053 Co
	80,0	90,0	6,0	83,0	> 4,0	WED 0800 0900 060 Co
	85,0	93,6	5,3	88,0	> 3,5	WED 0850 0936 053 CO
	85,0	95,0	6,0	88,0	> 4,0	WED 0850 0950 060 Co
	85,0	97,2	7,1	91,0	> 4,0	WED 0850 0972 071 Co
*	90,0	100,0	6,0	93,0	> 4,0	WED 0900 1000 060 Co
	90,0	102,2	7,1	96,0	> 4,0	WED 0900 1022 071 Co
	95,0	105,0	6,0	98,0	> 5,0	WED 0950 1050 060 Co



WED

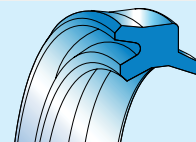

d_{H9}	D_{H10}	$E_{+0,2}$	$D_{10/+0,2}$	C	ART / ITEM
100,0	110,0	6,0	103,0	> 5,0	WED 1000 1100 060 Co
100,0	112,2	7,1	106,0	> 5,0	WED 1000 1122 071 Co
110,0	122,2	7,1	116,6	> 5,0	WED 1100 1222 071 Co
* 110,0	125,0	8,5	114,0	> 5,0	WED 1100 1250 085 Co
120,0	135,0	8,5	124,0	> 5,0	WED 1200 1350 085 Co
125,0	140,0	8,5	129,0	> 5,0	WED 1250 1400 085 Co
* 140,0	155,0	8,5	144,0	> 5,0	WED 1400 1550 085 Co
150,0	165,0	8,5	154,0	> 5,0	WED 1500 1650 085 Co
160,0	175,0	8,5	164,0	> 5,0	WED 1600 1750 085 Co
180,0	195,0	8,5	184,0	> 5,0	WED 1800 1950 085 Co

* in conformità alle norme ISO 6195 – in accordance with ISO 6195 norm

Nota: altre dimensioni non a catalogo a richiesta. Consultare il nostro ufficio tecnico.

Remark: please contact our technical dept. for further dimensions not included in the catalogue.

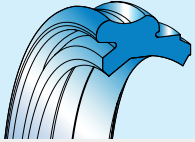

WDA

RASCHIATORE BIDIREZIONALE TIPO WDA

Descrizione

Progettato per essere una efficace seconda guarnizione a bassa pressione, il raschiatore bidirezionale tipo WDA presenta una geometria arrotondata nella parte statica che favorisce lo sfiato di olio in caso di microperdite.

Nella parte esterna, i labbri dinamici presentano un robusto labbro raschiante con piccolo raggio che, a contatto con lo stelo, mantiene le impurità all'esterno. Al tempo stesso facilita il rientro del film di olio evitando che rimanga sullo stelo.

Nella parte interna, il labbro a spigolo vivo lavora in tandem con la guarnizione primaria.

Dati tecnici

Velocità: < 0,8 m/s

Temperatura: da -35°C a $+100^{\circ}\text{C}$ con punte fino a 110°C .

Fluidi: agenti atmosferici, acqua a temperatura inferiore a 60°C , oli a base minerale
(v. tabella 3 a p. 14)

Materiale

Il materiale utilizzato è un poliuretano tipo Co con alto modulo elastico, basso compression-set ed elevata resistenza all'usura. Ha una durezza 93 Sh A ± 2

Codice materiale: Co

Montaggio

Lubrificare il raschiatore prima del montaggio ed eliminare bave di lavorazione della sede e spigoli taglienti per evitare danneggiamenti.

Fig.40-Pic.40:

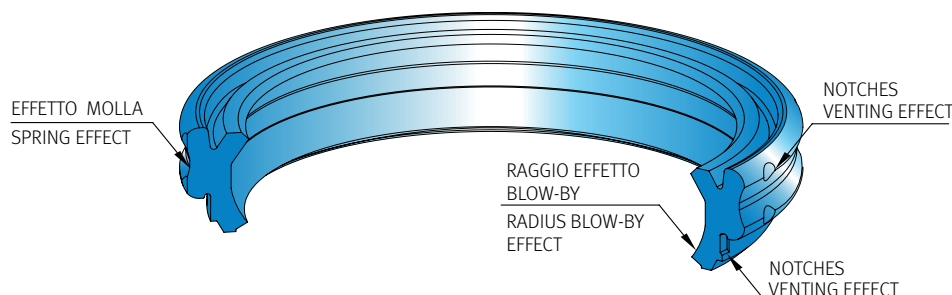

WDA TYPE DOUBLE ACTING WIPER

Description

The WDA bidirectional wiper has a rounded geometry in the static part to promote the oil venting in the event of micro leakage. It is designed to be an effective secondary seal at low pressure.

The dynamic lips have, on the outer part, a strong wiping lip with a small radius: when in contact with the rod this lip blocks any external impurities. At the same time, it makes the retreat of the oil film easier, preventing it from remaining on the rod. In the inner part the cutting edge lip works in conjunction with the main seal.

Technical data

Speed: < 0.8 m/s

Temperature: from -35°C to $+100^{\circ}\text{C}$ with peaks till 110°C .

Fluids: atmospheric factors, water at a temperature below 60°C , mineral oils
(see table 3, page 14)

Material

The material used is a Co-type polyurethane with high elasticity modulus, low compression-set and high resistance to wear.

The hardness is 93 Sh A ± 2

Compound reference: Co

Assembling

To prevent any damage to the wiper, remove all machining scores on the housing and cutting edges. The wiper should be lubricated before assembly.



WDA

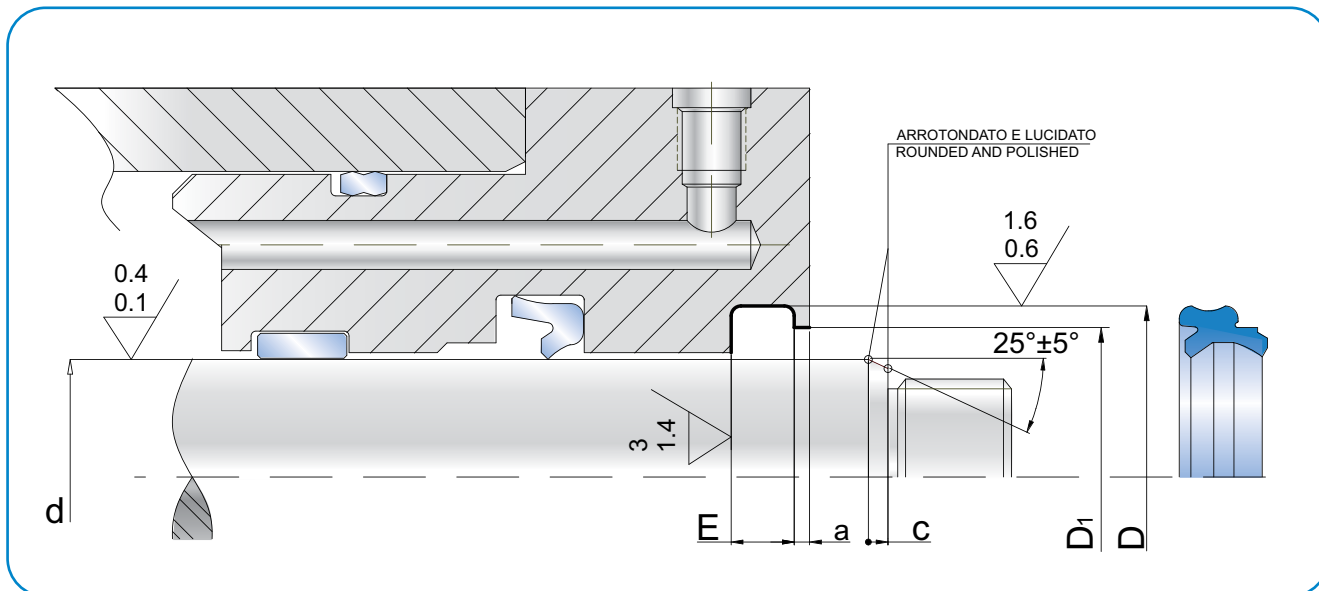
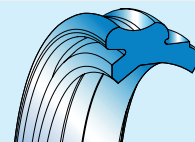

d_{hg}	D_{H10}	$E_{+0,2}$	$D_{10/+0,2}$	a	C	ART / ITEM
25,0	31,0	4,0	28,6	2,0	4,0	WDA 0250 0310 040 Co
30,0	38,0	5,0	35,2	2,0	4,0	WDA 0300 0380 050 Co
40,0	48,8	6,3	44,4	3,0	5,0	WDA 0400 0488 063 Co
42,0	50,8	6,3	46,4	3,0	5,0	WDA 0420 0508 063 Co
45,0	53,8	6,3	49,4	3,0	5,0	WDA 0450 0538 063 Co
50,0	58,8	6,3	54,4	3,0	5,0	WDA 0500 0588 063 Co
55,0	63,8	6,3	59,4	3,0	5,0	WDA 0550 0638 063 Co
60,0	68,8	6,3	64,4	3,0	5,0	WDA 0600 0688 063 Co
63,0	71,8	6,3	67,4	3,0	5,0	WDA 0630 0718 063 Co
65,0	73,8	6,3	69,4	3,0	5,0	WDA 0650 0738 063 Co
70,0	82,2	8,1	76,0	4,0	6,0	WDA 0700 0822 081 Co
75,0	87,2	8,1	81,0	4,0	6,0	WDA 0750 0872 081 Co
80,0	92,2	8,1	86,0	4,0	6,0	WDA 0800 0922 081 Co
85,0	97,2	8,1	91,0	4,0	6,0	WDA 0850 0972 081 Co
90,0	100,2	8,1	91,0	4,0	6,0	WDA 0900 1022 081 Co
95,0	107,2	8,1	101,0	4,0	6,0	WDA 0950 1072 081 Co
100,0	112,2	8,1	106,0	4,0	6,0	WDA 1000 1122 081 Co
105,0	117,2	8,1	111,0	4,0	6,0	WDA 1050 1172 081 Co
110,0	122,2	8,1	116,0	4,0	6,0	WDA 1100 1222 081 Co
115,0	127,2	8,1	121,0	4,0	6,0	WDA 1150 1272 081 Co
120,0	132,2	8,1	126,0	4,0	6,0	WDA 1200 1322 081 Co
125,0	137,2	8,1	131,0	4,0	6,0	WDA 1250 1372 081 Co

Nota: altre dimensioni non a catalogo a richiesta. Consultare il nostro ufficio tecnico.

Remark: please contact our technical dept. for further dimensions not included in the catalogue.

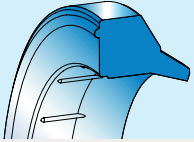

WIP

RASCHIATORE TIPO WIP

Descrizione

Il raschiatore tipo WIP si utilizza in condizioni di lavoro gravose, come cilindri per macchine movimento terra, per miniere e dove lo stelo supporta grosse flessioni. Le misure scelte sono per steli in pollici.

Dati tecnici

Velocità: < 0,8 m/s
 Temperatura: da - 40° C a + 90 ° C
 Fluidi: agenti atmosferici, acqua a temperatura inferiore a 60° C, oli a base minerale
 (v. tabella 3 a p. 14)

Materiale

I materiali utilizzati sono poliuretani con alto modulo elastico resistenti all'abrasione e agli agenti atmosferici. Il materiale standard è di durezza 90 Shore A.

In alternativa, in presenza di condizioni gravose in ambienti molto inquinati, sono utilizzabili poliuretani di durezza superiore. In questo caso consultare il nostro ufficio tecnico.

Codice materiale: Bo

Montaggio

Il montaggio, molto semplice, è in sede semiaperta. Eliminare bave e spigoli taglienti nella sede per non danneggiare la tenuta.
 Per ulteriori informazioni leggere le istruzioni a p. 63.

WIP TYPE WIPER

Description

The wiper type WIP applies when the conditions of application can be burden some, type cylinders for earthmoving machinery, mining cylinders, cylinders where the rod supports large deflections.
 The measurement stem from in inch sizes.

Technical data

Speed: < 0.8 m/s
 Temperature: from - 40° C to + 90 ° C
 Fluids: atmospheric factors, water at a temperature below 60° C, mineral oils
 (see table 3, page 14)

Material

The proposed material is a "Co" type polyurethane, with high elasticity modulus, low compression-set and high abrasion resistance.

The hardness is 90 Shore A ± 2.

Compound reference: Bo

It is also possible to use harder polyurethanes for heavy polluted environments.

In case please contact our technical department.

Assembling

The assembling is extremely easy because of the semi-open groove.

Remove flashes an/or cutting edges in the housing.

For further information please refer to the installation instructions on page 63.



WIP

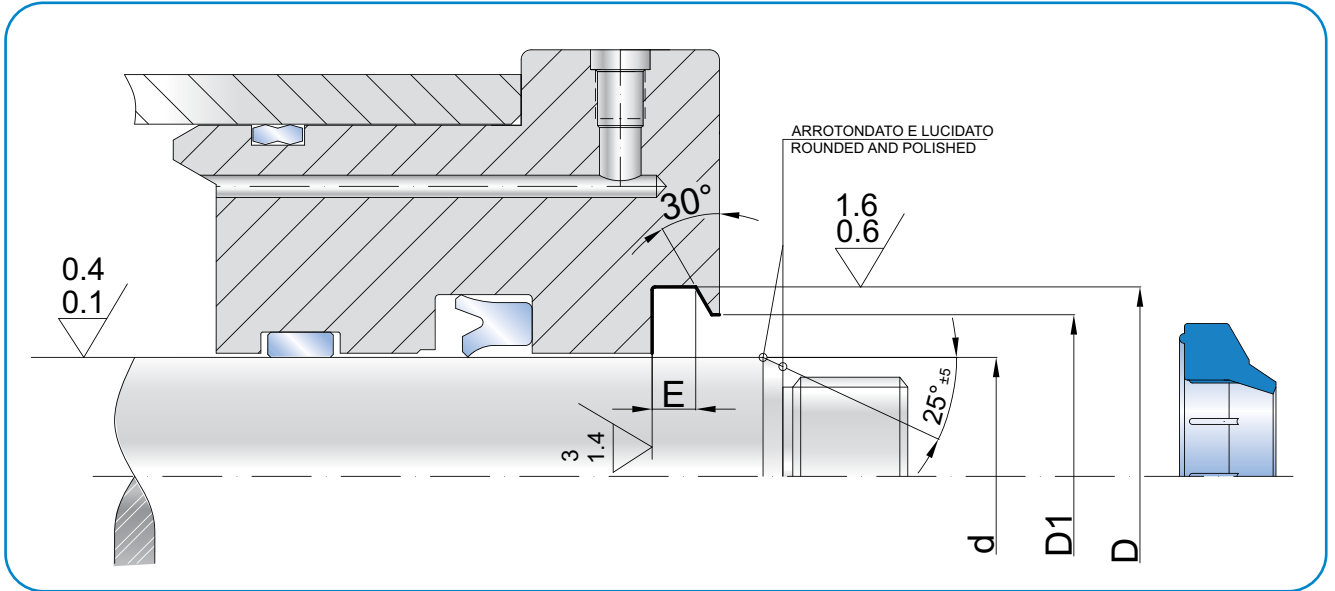
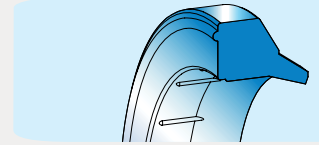

d _{hg}	D _{H10}	E _{+0,2}	D _{10/+0,2}	ART / ITEM
19,05	31,75	5,30	25,45	WIP 0750 1250 Bo
20,00	32,70	5,30	26,40	WIP 0780 1280 Bo
24,90	37,60	5,30	26,40	WIP 0980 1480 Bo
25,40	38,10	5,30	31,80	WIP 1000 1500 Bo
28,57	41,27	5,30	34,97	WIP 1125 1625 Bo
30,00	42,70	5,30	36,40	WIP 1180 1680 Bo
31,75	44,45	5,30	38,15	WIP 1250 1750 Bo
33,00	45,70	5,30	39,40	WIP 1290 1790 Bo
38,10	50,80	5,30	44,10	WIP 1500 2000 Bo
40,00	52,70	5,30	46,40	WIP 1575 2075 Bo
44,45	57,15	5,30	50,85	WIP 1750 2250 Bo
45,00	57,70	5,30	51,40	WIP 1770 2270 Bo
47,62	60,32	5,30	54,02	WIP 1875 2375 Bo
50,00	62,70	5,30	46,40	WIP 1970 2470 Bo
50,80	63,50	5,30	57,20	WIP 2000 2500 Bo
53,97	66,67	5,30	60,37	WIP 2125 2625 Bo
56,00	68,70	5,30	62,40	WIP 2200 2700 Bo
57,15	69,85	5,30	63,55	WIP 2250 2750 Bo

d _{hg}	D _{H10}	E _{+0,2}	D _{10/+0,2}	ART / ITEM
60,00	72,70	5,30	66,40	WIP 2360 2860 Bo
63,00	75,70	5,30	69,40	WIP 2480 2980 Bo
63,50	76,20	5,30	69,90	WIP 2500 3000 Bo
65,00	77,70	5,30	71,40	WIP 2550 3050 Bo
70,00	82,70	5,30	76,40	WIP 2750 3250 Bo
76,20	88,90	5,30	82,40	WIP 3000 3500 Bo
80,00	92,70	5,30	86,40	WIP 3150 3650 Bo
82,55	95,25	5,30	88,95	WIP 3250 3750 Bo
85,00	97,70	5,30	91,40	WIP 3340 3840 Bo
88,00	100,70	5,30	94,40	WIP 3460 3960 Bo
95,00	107,70	5,30	101,40	WIP 3740 4240 Bo
100,00	112,70	5,30	106,40	WIP 3930 4430 Bo
107,95	120,65	5,30	114,35	WIP 4250 4750 Bo
110,00	122,70	5,30	116,40	WIP 4330 4830 Bo

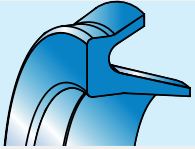

W N M

RASCHIATORE TIPO WNM

Descrizione

Il raschiatore tipo WNM è stato creato per applicazioni in cui è necessario eliminare materiali molto aggressivi (calcestruzzo, ghiaccio, cemento) dallo stelo.

Il labbro dinamico, più lungo e flessibile di quello statico, vince i disallineamenti dello stelo.

Dati tecnici

Velocità: < 0,8 m/s

Temperatura: da - 40° C a + 135 ° C con punte fino a 140° C.

Fluidi: agenti atmosferici, acqua a temperatura inferiore a 60° C, oli a base minerale
(v. tabella 3 a p. 14)

Materiale

Il materiale utilizzato, molto resistente all'abrasione, è un poliammide (PA) con bisolfuro di molibdeno (MoS₂).

Montaggio

Il montaggio avviene per pressione in cava semiaperta.

Si consiglia di ingrassare la sede per facilitare l'inserimento.

Per ulteriori informazioni leggere le istruzioni a p. 63.

WNM TYPE WIPER

Description

The WNM type Wiper has been created for applications where there is the need to eliminate very aggressive materials from the rod, such as concrete, ice, cement etc.

It is designed with the dynamic lip longer than the static one so that it is more flexible to win the misalignment of the rod.

Technical data

Speed: < 0.8 m/s

Temperature: from - 40° C to + 135° C with peaks till 140° C.

Fluids: atmospheric factors, water at a temperature below 60° C, mineral oils
(see table 3, page 14)

Material

the material used is a polyamide (PA) with molybdenum disulfide (MoS₂), a material highly resistant to abrasion.

Assembling

The assembly, by pressure occurs in semi open groove.

It is recommended to grease the seat for easy insertion.

For further information please refer to the installation instructions on page 63.

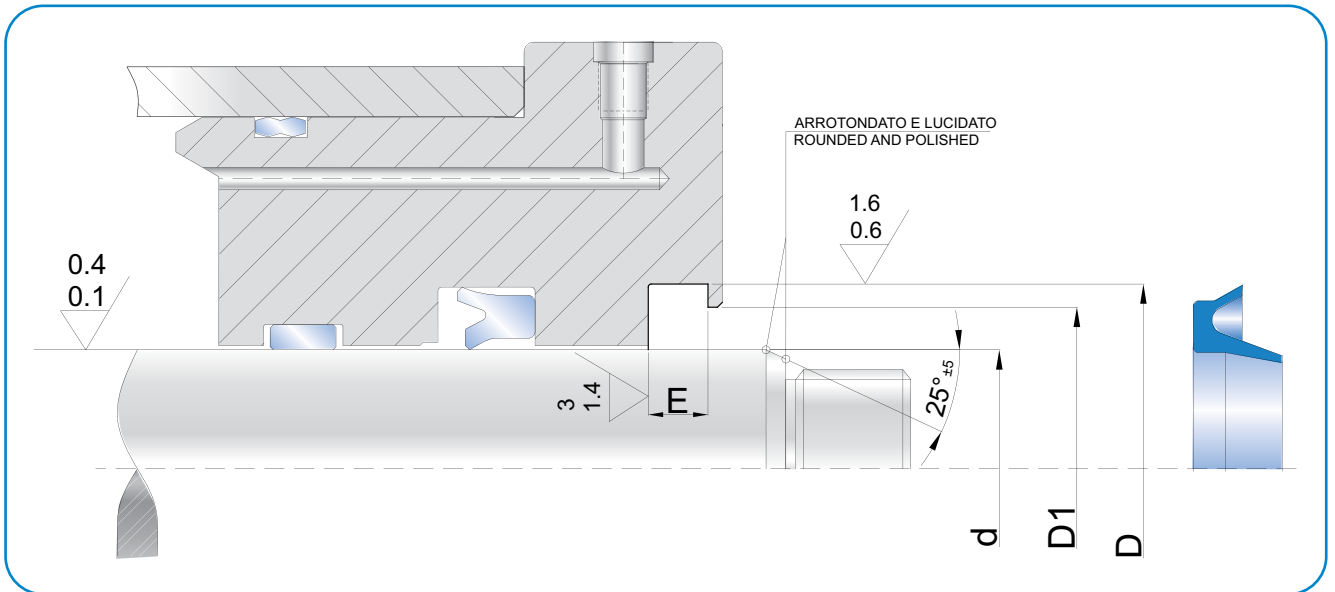
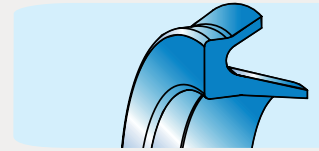

W N M

**Dimensioni metriche / Metric sizes****Dimensioni in inch / Inch sizes**

d _{h9}	D _{H10}	E _{+0,2}	D _{1 0/+0,2}	ART / ITEM
16,00	26,00	4,50	24,50	WNM 0160 0260 045 R4
20,00	33,00	6,00	31,50	WNM 0200 0330 060 R4
22,00	35,00	6,00	33,50	WNM 0220 0350 060 R4
25,00	38,00	6,00	36,50	WNM 0250 0380 060 R4
28,00	41,00	6,00	39,50	WNM 0280 0410 060 R4
30,00	43,00	6,00	41,50	WNM 0300 0430 060 R4
32,00	45,00	6,00	43,50	WNM 0320 0450 060 R4
36,00	49,00	6,00	47,50	WNM 0360 0490 060 R4
40,00	53,00	6,00	51,50	WNM 0400 0530 060 R4
45,00	58,00	6,00	56,50	WNM 0450 0580 060 R4
50,00	63,00	6,00	61,50	WNM 0500 0630 060 R4
55,00	68,00	6,00	66,50	WNM 0550 0680 060 R4
56,00	69,00	6,00	67,50	WNM 0560 0690 060 R4
60,00	73,00	6,00	71,50	WNM 0600 0730 060 R4
63,00	76,00	6,00	74,50	WNM 0630 0760 060 R4
65,00	78,00	6,00	76,50	WNM 0650 0780 060 R4
70,00	83,00	6,00	81,50	WNM 0700 0830 060 R4
75,00	88,00	6,00	86,50	WNM 0750 0880 060 R4
80,00	93,00	6,00	91,50	WNM 0800 0930 060 R4
90,00	103,00	6,00	101,50	WNM 0900 1030 060 R4
100,00	113,00	6,00	111,50	WNM 1000 1130 060 R4

d _{h9}	D _{H10}	E _{+0,2}	D _{1 0/+0,2}	ART / ITEM
12,70	22,22	4,36	20,62	WNM 0500 0875 0170 R4
19,05	31,75	5,95	30,15	WNM 0750 1250 0235 R4
22,22	34,92	5,95	33,32	WNM 0875 1375 0235 R4
25,40	38,10	5,95	36,50	WNM 1000 1500 0235 R4
28,57	41,27	5,95	39,68	WNM 1125 1625 0235 R4
31,75	44,45	5,95	42,85	WNM 1250 1750 0235 R4
38,10	50,80	5,95	49,20	WNM 1500 2000 0235 R4
44,45	57,15	5,95	55,55	WNM 1750 2250 0235 R4
50,80	63,50	5,95	61,90	WNM 2000 2500 0235 R4
63,50	76,20	5,95	74,60	WNM 2500 3000 0235 R4

Nota: altre dimensioni non a catalogo a richiesta. Consultare il nostro ufficio tecnico.

Remark: please contact our technical dept. for further dimensions not included in the catalogue.

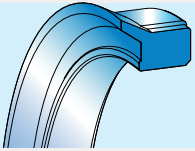

WEL

RASCHIATORE PER ESTERNO TIPO WEL

Descrizione

Il raschiatore tipo WEL è comunemente usato nei cilindri a semplice effetto aperti su un lato. Per evitare che la camicia sia deteriorata da agenti atmosferici, condensa o altro, si utilizza un raschiatore con profilo rovesciato che ha funzione di pulitore.

Dati tecnici

Velocità: < 0,8 m/s
 Temperatura: da - 35° C a + 100 ° C con punte fino a 110° C.
 Fluidi: agenti atmosferici, acqua a temperatura inferiore a 60° C, oli a base minerale
 (v. tabella 3 a p. 14)

Materiale

Il materiale utilizzato è un poliuretano tipo Co ad alto modulo elastico e a basso compression-set, con una elevata resistenza all'usura a 93 Shore A.
 Codice materiale: Co

Montaggio

Il montaggio avviene per accavallamento in sede semiaperta con aggancio, che ha la funzione di impedire l'espulsione del raschiatore durante l'inversione del ciclo. Importante togliere bave e spigoli per evitarne il danneggiamento.
 Per ulteriori informazioni leggere le istruzioni a p. 63.

WEL TYPE EXTERNAL WIPER

Description

The WEL wiper type is commonly used in simple effect cylinders open on one side. Because of its cleaning function, a reverse profile wiper is used to prevent bore wearing which may be caused by atmospheric agents, condensation and other environmental conditions.

Technical data

Speed: < 0.8 m/s
 Temperature: from - 35° C to + 100 ° C with peaks till 110° C.
 Fluids: atmospheric factors, water at a temperature below 60° C, mineral oils
 (see table 3, page 14)

Material

The proposed material is a "Co" type polyurethane, with high elasticity modulus, low compression-set and high abrasion resistance. The hardness is 93 Shore A ± 2.
 Compound reference: Co

Assembling

The assembling is done by overlapping in semi-open groove with a chamfer preventing the wiper extrusion during the cycle inversion. It is important to remove flashes or cutting edges to avoid damages.
 For further information please refer to the installation instructions on page 63.



WEL

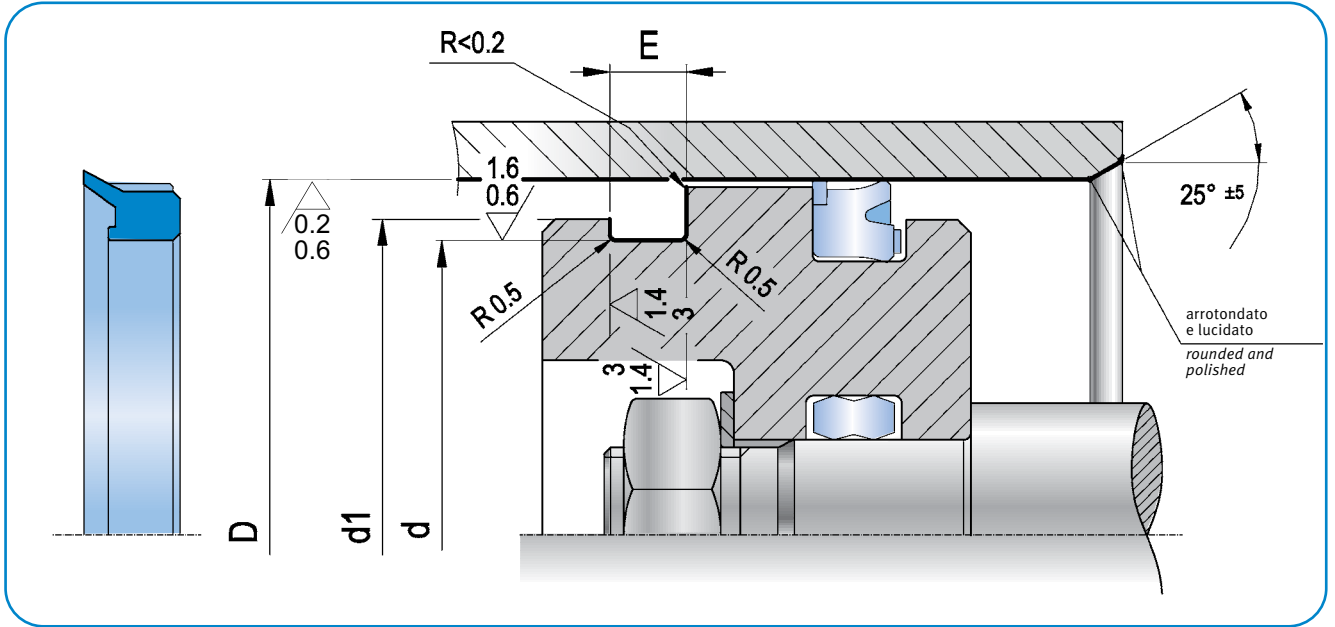
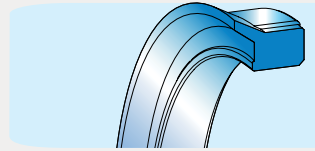

Oleodinamica
Hydraulic

D_{H9}	d_{h9}	$E_{+0,2}$	d_1	ART / ITEM
40,0	31,4	5,3	37,0	WEL 0400 0314 053 Co
45,0	36,4	5,3	42,0	WEL 0450 0364 053 Co
50,0	41,4	5,3	47,0	WEL 0500 0414 053 Co
60,0	51,4	5,3	57,0	WEL 0600 0514 053 Co
63,0	54,4	5,3	60,0	WEL 0630 0544 053 Co
70,0	61,4	5,3	67,0	WEL 0700 0614 053 Co
75,0	66,4	5,3	72,0	WEL 0750 0664 053 Co
80,0	71,4	5,3	77,0	WEL 0800 0714 053 Co
85,0	76,4	5,3	82,0	WEL 0850 0764 053 Co

D_{H9}	d_{h9}	$E_{+0,2}$	d_1	ART / ITEM
90,0	81,4	5,3	87,0	WEL 0900 0814 053 Co
95,0	86,4	5,3	92,0	WEL 0950 0864 053 Co
100,0	91,4	5,3	97,0	WEL 1000 0914 053 Co
110,0	101,4	5,3	107,0	WEL 1100 1014 053 Co
120,0	111,4	5,3	117,0	WEL 1200 1114 053 Co
140,0	131,4	5,3	137,0	WEL 1400 1314 053 Co

Nota: altre dimensioni non a catalogo a richiesta. Consultare il nostro ufficio tecnico.

Remark: please contact our technical dept. for further dimensions not included in the catalogue.

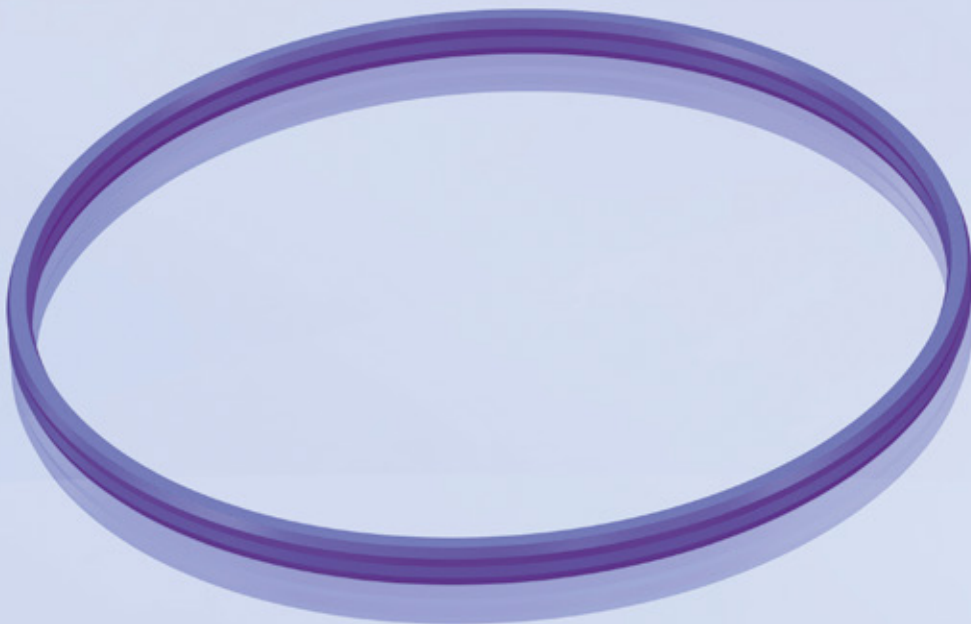



Tenute statiche *Static seals*



Tenute Statiche
Static Seals

Tenute statiche

Static seals

A completare il sistema di tenuta di un cilindro oleodinamico, oltre alle guarnizioni dinamiche per stelo e pistone, intervengono le guarnizioni statiche che assicurano la tenuta tra organi reciprocamente fissi.

Le guarnizioni statiche neutralizzano le fughe di fluido attraverso la filettatura esterna della testata e quella necessaria ad avvitare lo stelo al pistone. Esse sono normalmente realizzate con un o-ring in NBR spesso accoppiato a uno o due anelli antiestrusione che divengono necessari in presenza di pressioni elevate e giochi di accoppiamento eccessivi.

Oltre alle limitazioni poste da alte temperature o compatibilità con il fluido, sussiste spesso anche un problema di usura. In presenza di pressioni pulsanti, che comprimono e rilasciano l'o-ring, si genera un effetto che tende a limare l'elemento di tenuta provocando perdite in presenza di superfici di contatto con rugosità non accurata. Sotto questo aspetto risulta estremamente vantaggioso l'impiego di guarnizioni tipo SSA in poliuretano che risolvono il problema, facilitano il montaggio e utilizzano un solo elemento anziché due (o-ring e antiestrusione).

In addition to the already described rod and piston dynamic seals, further components granting the sealing between reciprocating static elements are involved in the hydraulic cylinder sealing system. Static seals prevents leakages of fluid by the head external screw-thread and the thread for tightening the rod to the piston.

The seals are usually composed by a NBR o-ring combined with one or two anti-extrusion rings, necessary in cases of high pressure and excessive coupling clearance.





Besides the limitations resulting from high temperatures or fluid compatibility issues, wear is also a common problem. Pulsating pressures loading or unloading the o-ring, when the roughness of the contact surface does not comply with the specification range, cause "filing" of the sealing part originating a leakage.

The use of a SSA polyurethane seal is more appropriate facing this effect, having also the advantage to have a easier assembling because of one single element instead of two (o-ring and anti-extrusion ring).



Profili

Profile

GUARNIZIONI STATICHE / <i>STATIC SEALS</i>													
Condizioni massime non simultanee / <i>Maximum conditions (not combined)</i>													
Profilo <i>Profile</i>	Ns Rif. <i>Our Ref.</i>	Temperatura <i>Temperature</i> C°	Pressione <i>Pressure</i> Bar	Velocità <i>Speed</i> m/s	Materiale <i>Material</i>	TPU	POM / PA	PTFE Bronze	NBR	TPE Resina PTFE Carbo.	PTFE	Sezione <i>Section</i>	Pagina <i>Page</i>
	SSA	-35 +100	< 400	-	TPU	●						Statica <i>Static</i>	222
	VSS	-35 +100	< 400	-	TPU	●						Statica <i>Static</i>	228
	FSA	-35 +100	< 500	-	TPU	●						Statica <i>Static</i>	232
	VRA	-40 +90	-	-	TPU	●						Statica <i>Static</i>	234

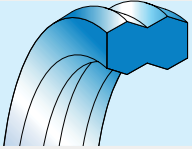

SSA

GUARNIZIONE STATICA TIPO SSA

Descrizione

Studiata e collaudata da molti anni, la guarnizione tipo SSA è utilizzata per impieghi statici ma anche dinamici in alcune applicazioni. Impiegata principalmente in sostituzione di un o-ring e di un anello antiestrusione, è costituita da un anello in poliuretano ad alto modulo elastico e a basso compression-set che impedisce l'attorcigliamento durante il montaggio e l'estrusione in esercizio. L'utilizzo di un solo pezzo e il profilo a doppie punte simmetrico facilitano il montaggio all'operatore e dimezzano lo stock di magazzino.

Limiti d'impiego

Pressione: < 400 bar a temperatura di 60° C
 Temperatura: da - 35° C a + 100° C, con punte fino a + 110° C
 Fluidi: olio e grassi minerali, gas non aggressivi (v. tabella 3 a p. 14)

Materiale

Il materiale utilizzato è un poliuretano tipo Co ad alto modulo elastico e a basso compression-set, con una elevata resistenza all'usura a 93 Shore A.
 Codice materiale: Co

Montaggio

È importante eliminare gli spigoli vivi e le bave nella sede ed eseguire uno smusso di invito per facilitare il montaggio.

Nota: in caso di montaggio su testata flottante, si raccomanda di contattare il nostro ufficio tecnico per verificare l'adeguatezza dei giochi di accoppiamento.

SSA TYPE STATIC SEAL

Description

The SSA type static seal has been developed and tested for many years for static and sometimes dynamic sealing applications. It is mainly used as replacement of o-ring and anti-extrusion ring. The use of a high modulus polyurethane with a low compression-set prevents winding during assembling and avoid extrusion in working conditions. One single piece with symmetrical profile allows the operator easier installation reducing at the same time the stock handling.

Technical data

Pressure: < 400 bar at a temperature of 60°C
 Temperature: from - 35° C to + 100° C with peaks till + 110° C
 Fluids: mineral oil and grease, non aggressive gas
 (see table 3, page 14)

Material

The proposed material is a "Co" type polyurethane, with high elasticity modulus, low compression-set and high abrasion resistance. The hardness is 93 Shore A ± 2.
 Compound reference: Co

Assembling

It is important to remove flashes or cutting edges to avoid damages. It's also recommended to make a lead-in chamfer for easier assembling.

Note: for usage in floating head please contact our technical engineer to verify the consistency of the coupling clearance.



SSA

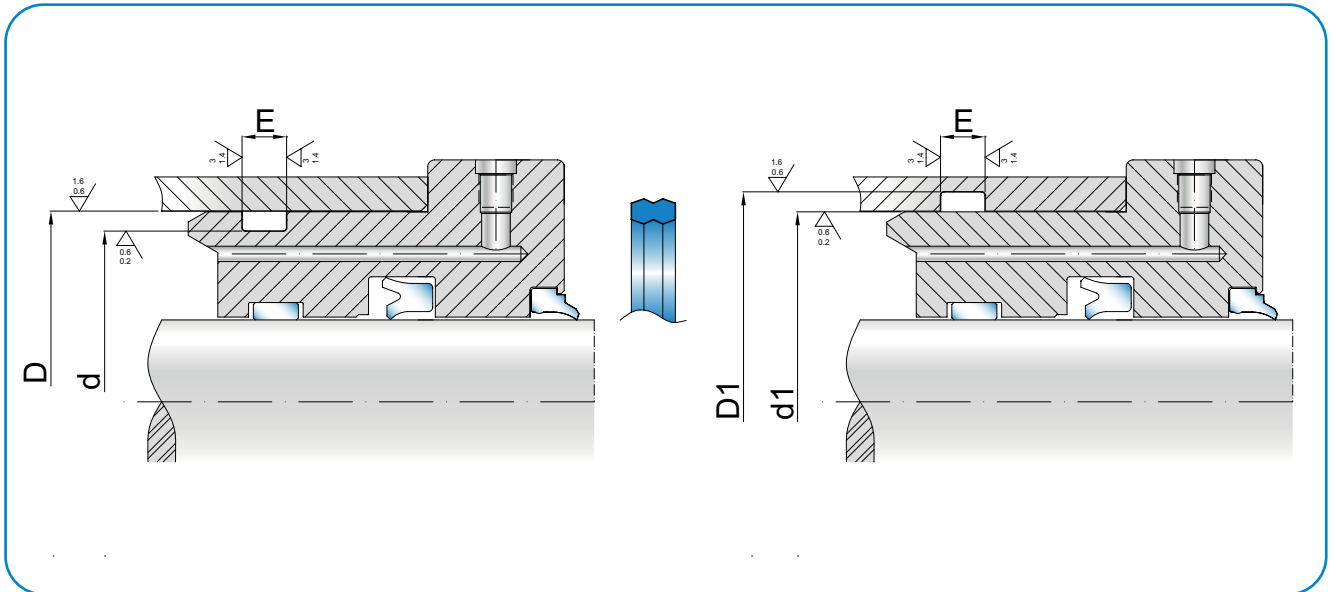
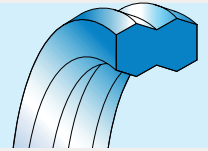

D _{H10}	d _{h9}	E _{+0,2}	R	d _{1h9}	D _{1H10}	ART / ITEM
10,00	7,40	2,2	0,2			SSA 0100 0074 022 Co
10,00	7,40	3,8	0,2	8,0	10,60	SSA 0100 0074 038 Co
10,00	7,60	3,6	0,2			SSA 0100 0076 036 Co
12,00	9,40	2,2	0,2			SSA 0120 0094 022 Co
12,00	9,40	3,8	0,2			SSA 0120 0094 038 Co
12,60	10,30	3,1	0,2			SSA 0126 0103 031 Co
12,65	9,90	2,5	0,2	10,0	12,60	SSA 0126 0099 025 Co
13,00	10,20	2,5	0,2			SSA 0130 0102 025 Co
14,00	11,20	2,5	0,2			SSA 0140 0112 025 Co
14,00	11,40	3,8	0,2	12,00	14,60	SSA 0140 0114 038 Co
14,22	11,47	2,5	0,2			SSA 0142 0114 025 Co
14,20	11,90	3,1	0,2			SSA 0142 0119 031 Co
15,00	11,90	2,5	0,2			SSA 0150 0119 025 Co
15,00	11,90	4,0	0,2	11,00	14,10	SSA 0150 0119 040 Co
15,00	12,20	2,5	0,2			SSA 0150 0122 025 Co
15,00	12,40	3,8	0,2	13,00	15,60	SSA 0150 0124 038 Co
15,00	12,60	3,0	0,2			SSA 0150 0126 030 Co
15,80	13,50	3,1	0,2			SSA 0158 0135 031 Co
15,82	13,07	2,5	0,2			SSA 0158 0130 025 Co
15,87	13,00	3,5	0,2			SSA 0159 0130 035 Co
16,00	12,90	2,5	0,2			SSA 0160 0129 025 Co
16,00	13,40	2,2	0,2			SSA 0160 0134 022 Co
16,00	13,40	3,8	0,2	14,00	16,60	SSA 0160 0134 038 Co
16,50	12,00	3,5	0,2			SSA 0165 0120 035 Co

D _{H10}	d _{h9}	E _{+0,2}	R	d _{1h9}	D _{1H10}	ART / ITEM
17,00	14,20	2,5	0,2			SSA 0170 0142 025 Co
17,00	14,60	3,4	0,2			SSA 0170 0146 034 Co
17,40	15,00	3,1	0,2			SSA 0174 0150 031 Co
17,47	14,60	3,5	0,2			SSA 0175 0146 035 Co
18,00	14,90	2,5	0,2			SSA 0180 0149 025 Co
18,00	14,90	4,0	0,2	14,00	17,10	SSA 0180 0149 040 Co
18,00	15,20	2,5	0,2			SSA 0180 0152 025 Co
18,00	15,40	3,8	0,2	16,00	18,60	SSA 0180 0154 038 Co
18,00	15,60	3,4	0,2			SSA 0180 0156 034 Co
18,50	14,00	3,5	0,2			SSA 0185 0140 035 Co
19,00	15,90	2,5	0,2			SSA 0190 0159 025 Co
19,00	15,90	4,0	0,2	16,00	19,10	SSA 0190 0159 040 Co
19,00	16,20	2,5	0,2			SSA 0190 0162 025 Co
19,00	16,60	2,4	0,2			SSA 0190 0166 024 Co
19,00	16,60	3,1	0,2			SSA 0190 0166 031 Co
19,05	16,20	3,5	0,2			SSA 0190 0162 035 Co
20,00	14,50	3,5	0,2			SSA 0200 0145 035 Co
20,00	16,60	3,4	0,2			SSA 0200 0166 034 Co
20,00	17,40	3,4	0,2			SSA 0200 0174 034 Co
20,00	17,40	3,8	0,2	18,00	20,60	SSA 0200 0174 038 Co
20,62	17,80	3,5	0,2			SSA 0206 0178 035 Co
21,00	17,60	4,4	0,2			SSA 0210 0176 044 Co
21,00	18,60	3,6	0,2			SSA 0210 0186 036 Co
21,50	17,00	3,5	0,2			SSA 0215 0170 035 Co

Nota: altre dimensioni non a catalogo a richiesta. Consultare il nostro ufficio tecnico.

Remark: please contact our technical dept. for further dimensions not included in the catalogue.

Tenute Statiche
Static Seals

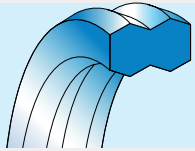

SSA

D _{H10}	d _{h9}	E _{+0,2}	R	d _{ih9}	D _{1H10}	ART / ITEM
22,00	19,40	2,2	0,2			SSA 0220 0194 022 Co
22,00	19,40	3,8	0,2	20,00	22,60	SSA 0220 0194 038 Co
23,00	19,60	4,4	0,2			SSA 0230 0196 044 Co
23,00	20,00	3,8	0,2			SSA 0230 0200 038 Co
23,00	20,60	3,4	0,2			SSA 0230 0206 034 Co
23,80	21,20	3,8	0,2			SSA 0238 02129 038 Co
24,00	20,00	4,8	0,2			SSA 0240 0200 048 Co
24,00	21,40	3,8	0,2	22,00	24,60	SSA 0240 0214 038 Co
25,00	20,50	3,5	0,2			SSA 0250 0205 035 Co
25,00	20,50	5,0	0,2	20,00	24,50	SSA 0250 0205 050 Co
25,00	22,40	3,8	0,2	23,00	25,60	SSA 0250 0224 038 Co
25,00	22,60	2,4	0,2			SSA 0250 0226 024 Co
26,00	21,80	3,5	0,2			SSA 0260 0218 035 Co
26,00	22,00	5,0	0,2	22,00	26,00	SSA 0260 0220 050 Co
26,560	22,00	3,5	0,2			SSA 0265 0220 035 Co
27,00	22,80	3,5	0,2			SSA 0270 0228 035 Co
28,00	23,00	5,3	0,2			SSA 0280 0230 053 Co
28,00	23,80	3,5	0,2			SSA 0280 0238 035 Co
28,00	24,00	5,0	0,2	24,00	28,00	SSA 0280 0240 050 Co
29,00	24,50	3,5	0,2			SSA 0290 0245 035 Co
29,00	24,90	5,0	0,2	24,00	28,10	SSA 0290 0249 050 Co
30,00	26,00	5,0	0,2	26,00	30,00	SSA 0300 0260 050 Co
30,00	27,10	3,6	0,2			SSA 0300 0271 036 Co
32,00	28,00	5,0	0,2	28,00	32,00	SSA 0320 0280 050 Co
34,00	28,40	4,3	0,2			SSA 0340 0284 045 Co
34,00	30,00	5,0	0,2	30,00	34,00	SSA 0340 0300 050 Co
34,00	28,40	5,3	0,2			SSA 0340 0284 053 Co
35,00	30,40	5,0	0,2			SSA 0350 0304 050 Co
35,60	29,50	4,5	0,2			SSA 0356 0295 045 Co
36,00	30,40	4,5	0,2			SSA 0360 0304 045 Co
36,00	32,00	5,0	0,2	32,00	36,00	SSA 0360 0320 050 Co
37,00	30,80	4,5	0,2			SSA 0370 0308 045 Co
38,00	31,80	4,5	0,2			SSA 0380 0318 045 Co
38,00	32,40	4,5	0,2			SSA 0380 0324 045 Co
38,60	34,00	4,0	0,2			SSA 0386 0340 040 Co
39,00	33,40	5,3	0,2			SSA 0390 0334 053 Co
40,00	33,80	6,0	0,2			SSA 0400 0338 060 Co
40,00	34,40	4,8	0,2			SSA 0400 0344 048 Co
40,00	36,00	3,4	0,2			SSA 0400 0360 034 Co
40,00	36,00	5,0	0,2	36,00	40,00	SSA 0400 0360 050 Co
41,00	36,00	3,7	0,2			SSA 0410 0360 037 Co
41,00	37,00	3,4	0,2			SSA 0420 0360 050 Co

D _{H10}	d _{h9}	E _{+0,2}	R	d _{ih9}	D _{1H10}	ART / ITEM
42,00	36,00	5,0	0,2			SSA 0420 0360 050 Co
42,00	36,40	4,8	0,2			SSA 0420 0364 048 Co
42,00	37,90	5,0	0,2			SSA 0420 0379 050 Co
42,00	38,00	3,2	0,2			SSA 0420 0380 032 Co
42,00	38,00	5,0	0,2	38,00	42,00	SSA 0420 0380 050 Co
42,00	39,10	3,6	0,2			SSA 0420 0391 036 Co
43,00	37,40	5,3	0,2			SSA 0430 0374 053 Co
44,45	38,45	5,3	0,2			SSA 0445 0385 053 Co
45,00	41,00	5,0	0,2	41,00	45,00	SSA 0450 0410 050 Co
45,00	40,00	5,4	0,2			SSA 0450 0400 054 Co
45,60	41,00	4,0	0,2			SSA 0456 0410 040 Co
47,00	42,00	5,4	0,2	42,00		SSA 0470 0420 054 Co
48,00	42,30	5,3	0,2			SSA 0480 0423 053 Co
48,00	42,60	6,2	0,2	43,00	48,40	SSA 0480 0426 062 Co
48,00	43,00	3,6	0,2			SSA 0480 0430 036 Co
49,20	43,00	4,5	0,2			SSA 0492 0430 045 Co
50,00	41,30	8,5	0,2			SSA 0500 0438 060 Co
50,00	43,80	6,0	0,2			SSA 0500 0438 060 Co
50,00	44,40	5,3	0,2			SSA 0500 0444 053 Co
50,00	45,40	3,9	0,2			SSA 0500 0454 039 Co
50,00	45,40	5,4	0,2			SSA 0500 0454 054 Co
50,00	44,60	6,2	0,2	45,00	50,40	SSA 0500 0446 062 Co
50,50	46,00	3,5	0,2			SSA 0505 0460 035 Co
50,60	44,50	5,5	0,2			SSA 0506 0445 055 Co
50,00	47,50	3,6	0,2			SSA 0500 0475 036 Co
50,80	45,20	5,3	0,3			SSA 0508 0452 053 Co
51,00	46,4	3,9	0,3			SSA 0510 0464 039 Co
51,00	46,5	3,5	0,3			SSA 0510 0465 035 Co
51,00	46,5	5,0	0,3			SSA 0510 0465 050 Co
52,00	46,60	6,2	0,3	47,00	52,40	SSA 0520 0466 062 Co
53,00	48,00	3,6	0,2			SSA 0530 0480 036 Co
53,00	48,00	5,4	0,3			SSA 0530 0480 054 Co
54,00	48,10	4,5	0,3			SSA 0540 0481 045 Co
54,40	48,70	5,3	0,3			SSA 0544 0487 053 Co
55,00	46,30	8,5	0,3			SSA 0550 0463 085 Co
55,00	49,60	4,8	0,3			SSA 0550 0496 048 Co
55,00	49,60	6,2	0,3	50,00	55,40	SSA 0550 0496 062 Co
55,00	49,90	5,3	0,3			SSA 0550 0499 053 Co
55,00	50,50	5,0	0,3			SSA 0550 0505 050 Co
55,00	50,50	6,4	0,3			SSA 0550 0505 064 Co
55,00	51,00	3,5	0,3			SSA 0550 0510 035 Co
57,00	52,20	4,1	0,3			SSA 0570 0522 041 Co



SSA

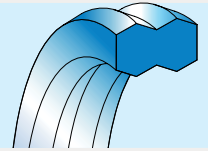

D _{H10}	d _{h9}	E _{+0,2}	R	d _{1h9}	D _{1H10}	ART / ITEM		
57,15	51,15	5,3	0,3			SSA 0572	0512	053 Co
58,20	52,00	4,5	0,3			SSA 0600	0538	060 Co
60,00	53,80	6,0	0,3			SSA 0600	0538	060 Co
60,00	54,30	5,8	0,3			SSA 0600	0543	058 Co
60,00	54,40	5,8	0,3			SSA 0600	0544	058 Co
60,00	54,60	6,2	0,3	55,00	60,40	SSA 0600	0546	062 Co
60,00	55,00	5,3	0,3			SSA 0600	0550	053 Co
60,00	55,90	4,4	0,3			SSA 0600	0559	044 Co
60,00	56,00	5,0	0,3			SSA 0600	0560	050 Co
60,70	55,00	5,3	0,3			SSA 0607	0550	053 Co
61,00	56,5	3,5	0,3			SSA 0610	0565	035 Co
61,00	56,5	5,0	0,3			SSA 0610	0565	050 Co
61,50	56,00	2,8	0,3			SSA 0615	0560	028 Co
61,50	56,00	4,0	0,3			SSA 0615	0560	040 Co
63,00	57,40	4,8	0,3			SSA 0630	0574	048 Co
63,20	57,00	4,5	0,3			SSA 0632	0570	045 Co
63,50	57,50	5,3	0,3			SSA 0635	0575	053 Co
64,00	58,40	4,5	0,3			SSA 0640	0584	045 Co
64,50	59,00	4,6	0,3			SSA 0645	0590	046 Co
65,00	59,40	5,0	0,3			SSA 0650	0594	050 Co
65,00	59,60	6,2	0,3	60,00	65,40	SSA 0650	0596	062 Co
65,00	60,00	5,0	0,3			SSA 0650	0600	050 Co
65,00	60,40	4,0	0,3			SSA 0650	0604	040 Co
66,00	60,40	5,1	0,3			SSA 0660	0604	051 Co
69,60	65,00	3,9	0,3			SSA 0696	0650	039 Co
70,00	63,80	6,0	0,3			SSA 0700	0638	060 Co
70,00	64,40	6,0	0,3			SSA 0700	0644	060 Co
70,00	64,60	6,2	0,3	65,00	70,40	SSA 0700	0646	062 Co
70,00	65,00	5,0	0,3			SSA 0700	0650	050 Co
71,50	66,00	4,6	0,3			SSA 0715	0660	046 Co
72,00	66,40	5,0	0,3			SSA 0720	0664	050 Co
72,60	68,00	3,8	0,3			SSA 0726	0680	038 Co
74,60	70,00	3,8	0,3			SSA 0746	0700	038 Co
75,00	69,40	5,3	0,3			SSA 0750	0694	053 Co
75,00	69,60	6,2	0,3	70,00	75,40	SSA 0750	0696	062 Co
75,00	70,70	4,4	0,3			SSA 0750	0707	044 Co
75,60	70,00	5,3	0,3			SSA 0756	0700	053 Co
76,20	70,20	5,3	0,3			SSA 0762	0702	053 Co
76,60	72,00	4,8	0,3			SSA 0766	0720	048 Co
79,20	73,00	4,5	0,3			SSA 0792	0730	045 Co
80,00	73,60	6,4	0,3			SSA 0800	0736	064 Co
80,00	73,80	6,0	0,3			SSA 0800	0738	060 Co
80,00	74,40	5,3	0,3			SSA 0800	0744	053 Co
80,00	74,60	6,2	0,3	75,00	80,40	SSA 0800	0746	062 Co
80,00	75,40	5,4	0,3			SSA 0800	0754	054 Co
80,60	76,00	6,4	0,3			SSA 0806	0760	064 Co
81,00	74,80	4,5	0,3			SSA 0810	0748	045 Co
81,00	74,80	6,0	0,3			SSA 0810	0748	060 Co
81,00	75,40	4,5	0,3			SSA 0810	0754	045 Co
84,70	78,58	4,9	0,3			SSA 0847	0786	049 Co
85,00	78,50	6,4	0,3			SSA 0850	0785	064 Co
85,00	79,40	5,3	0,3			SSA 0850	0794	053 Co
85,00	79,60	6,2	0,3	80,00	85,40	SSA 0850	0796	062 Co
85,10	80,50	3,9	0,3			SSA 0851	0805	039 Co
86,30	81,80	4,9	0,3			SSA 0863	0818	049 Co
88,00	82,40	7,0	0,3			SSA 0880	0824	070 Co
88,00	84,20	7,0	0,3			SSA 0880	0842	070 Co
88,20	81,80	5,0	0,3			SSA 0882	0818	050 Co
89,00	82,80	6,0	0,3			SSA 0890	0828	060 Co
90,00	80,60	9,0	0,3			SSA 0900	0806	090 Co
90,00	81,40	9,0	0,3	80,00	88,60	SSA 0900	0814	090 Co
90,00	83,00	6,5	0,3			SSA 0900	0830	065 Co
90,00	84,30	6,7	0,3			SSA 0900	0843	067 Co
90,00	84,40	4,8	0,3			SSA 0900	0844	048 Co
91,50	86,00	4,6	0,3			SSA 0915	0860	046 Co
92,00	86,50	4,8	0,3			SSA 0920	0865	048 Co
93,00	87,40	5,3	0,3			SSA 0930	0874	053 Co
94,00	89,50	3,8	0,3			SSA 0940	0895	038 Co
95,00	86,40	9,0	0,3	85,00	93,60	SSA 0950	0864	090 Co
95,00	89,40	6,2	0,3			SSA 0950	0894	062 Co
95,00	90,00	5,5	0,3			SSA 0950	0900	055 Co
97,00	92,70	4,4	0,3			SSA 0970	0927	044 Co
99,00	92,80	6,0	0,3			SSA 0990	0928	060 Co
100,00	90,60	7,0	0,4			SSA 1000	0906	070 Co
100,00	90,60	9,0	0,4			SSA 1000	0906	090 Co
100,00	90,80	9,7	0,4			SSA 1000	0908	097 Co
100,00	91,40	7,0	0,4			SSA 1000	0914	070 Co
100,00	91,40	9,0	0,4	90,00	98,60	SSA 1000	0914	090 Co
100,00	94,30	5,3	0,4			SSA 1000	0943	053 Co
101,00	93,70	5,2	0,4			SSA 1010	0937	052 Co
101,00	94,70	5,2	0,4			SSA 1010	0947	052 Co
101,50	96,00	4,6	0,4			SSA 1015	0960	046 Co
102,00	95,80	4,5	0,4			SSA 1020	0958	045 Co
102,00	95,80	6,0	0,4			SSA 1020	0958	060 Co

Nota: altre dimensioni non a catalogo a richiesta. Consultare il nostro ufficio tecnico.

Remark: please contact our technical dept. for further dimensions not included in the catalogue.

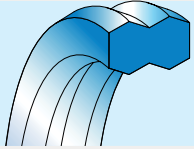

SSA

D _{H10}	d _{h9}	E _{+0,2}	R	d _{ih9}	D _{iH10}	ART / ITEM			D _{H10}	d _{h9}	E _{+0,2}	R	d _{ih9}	D _{iH10}	ART / ITEM				
102,50	96,60	5,5	0,4			SSA 1025	0966	055	Co	140,00	131,60	8,6	0,4			SSA 1400	1316	086	Co
104,00	99,50	3,8	0,4			SSA 1040	0995	038	Co	150,00	138,40	12,4	0,4	140,00	151,60	SSA 1500	1384	124	Co
105,00	96,40	9,0	0,4	95,00	103,60	SSA 1050	0964	090	Co	150,00	141,40	8,0	0,4			SSA 1500	1414	080	Co
108,00	98,90	7,2	0,4			SSA 1080	0989	072	Co	150,00	145,80	9,0	0,4			SSA 1500	1458	090	Co
110,00	101,40	9,0	0,4	100,00	108,60	SSA 1100	1014	090	Co	160,00	148,40	12,4	0,4	150,00	161,60	SSA 1600	1484	124	Co
110,00	104,50	4,5	0,4			SSA 1100	1045	045	Co	160,00	151,40	8,0	0,4			SSA 1600	1514	080	Co
110,50	104,70	6,0	0,4			SSA 1105	1047	060	Co	160,00	154,40	3,6	0,4			SSA 1600	1544	036	Co
113,00	107,40	5,3	0,4			SSA 1130	1074	053	Co	165,00	156,60	8,6	0,4			SSA 1650	1566	086	Co
115,00	106,40	9,0	0,4	105,00	113,60	SSA 1150	1064	090	Co	170,00	151,40	8,0	0,4			SSA 1700	1514	080	Co
115,00	108,00	4,6	0,4			SSA 1150	1080	046	Co	170,00	158,40	12,4	0,4	160,00	171,60	SSA 1700	1584	124	Co
120,00	111,40	9,0	0,4	110,00	118,60	SSA 1200	1114	090	Co	180,00	168,40	12,4	0,4	170,00	181,60	SSA 1800	1684	124	Co
120,00	113,00	6,0	0,4			SSA 1200	1130	060	Co	190,00	178,40	12,4	0,4	180,00	191,60	SSA 1900	1784	124	Co
120,00	113,80	5,3	0,4			SSA 1200	1138	053	Co	200,00	188,40	12,4	0,4	190,00	201,60	SSA 2000	1884	124	Co
120,00	115,40	5,4	0,4			SSA 1200	1154	054	Co	210,00	200,8	9,0	0,4			SSA 2100	2008	090	Co
124,00	115,00	7,0	0,4			SSA 1240	1150	070	Co	220,00	210,40	9,0	0,4			SSA 2200	2104	090	Co
125,00	116,40	9,0	0,4	115,00	123,60	SSA 1250	1164	090	Co	225,00	213,40	12,4	0,4	215,00	226,60	SSA 2250	2134	124	Co
130,00	120,60	9,5	0,4			SSA 1300	1206	095	Co	244,00	231,00	8,5	0,4			SSA 2440	2310	085	Co
130,00	121,40	9,0	0,4	120,00	128,60	SSA 1300	1214	090	Co	250,00	238,40	12,4	0,4	240,00	251,60	SSA 2500	2384	124	Co
130,00	121,60	8,2	0,4			SSA 1300	1216	082	Co	251,00	238,40	12,4	0,4			SSA 2510	2384	124	Co
135,00	126,40	9,0	0,4	125,00	133,60	SSA 1350	1264	090	Co	270,00	258,40	12,4	0,4	260,00	271,60	SSA 2700	2584	124	Co
140,00	131,40	9,0	0,4	130,00	138,60	SSA 1400	1314	090	Co	280,00	268,40	12,4	0,4	270,00	281,60	SSA 2800	2684	124	Co

Nota: altre dimensioni non a catalogo a richiesta. Consultare il nostro ufficio tecnico.

Remark: please contact our technical dept. for further dimensions not included in the catalogue.



SSA

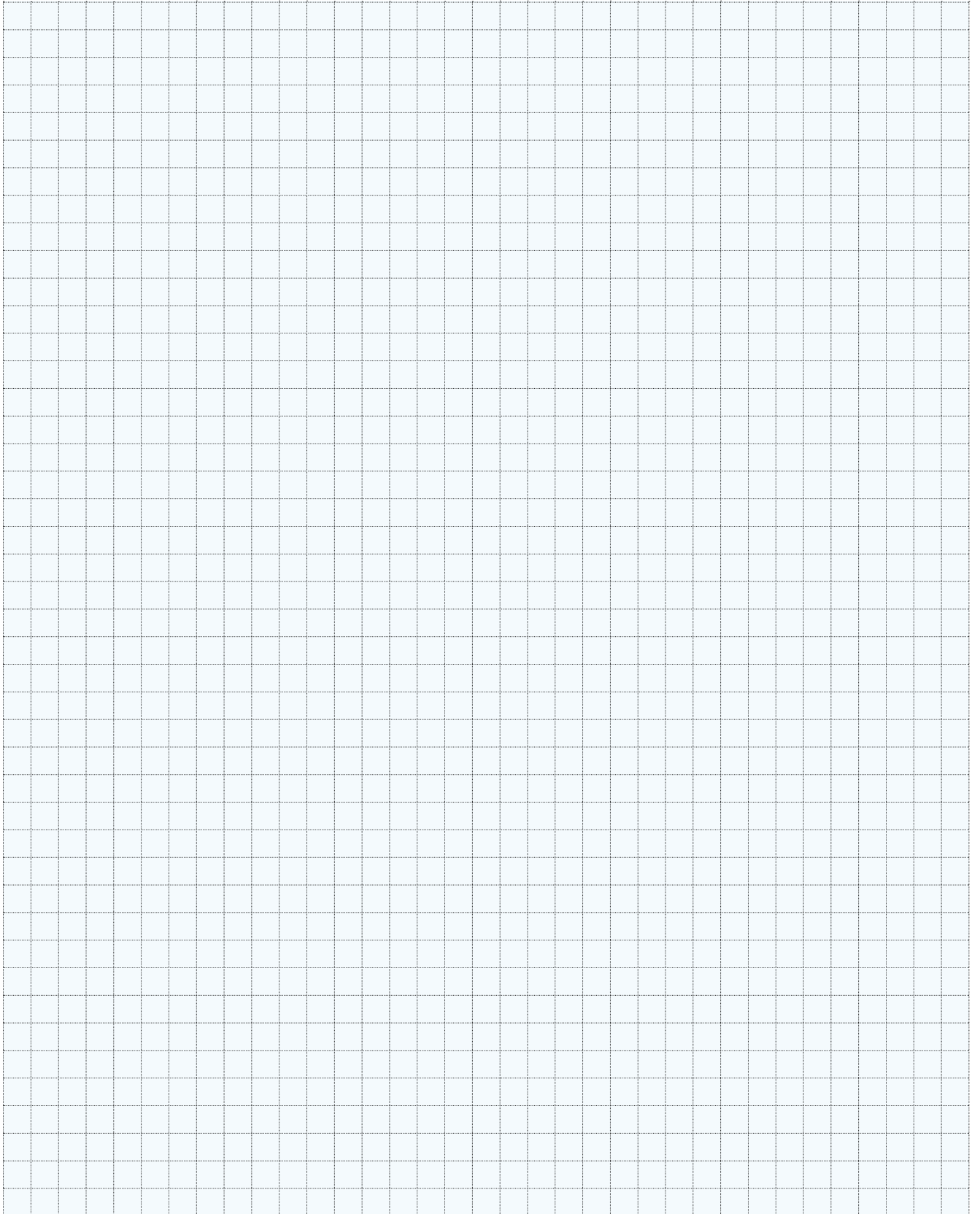
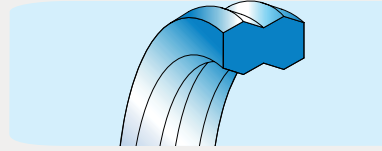

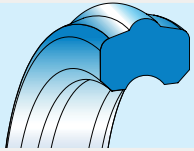

VSS

TENUTE PER VALVOLE A CARTUCCIA TIPO VSS

Descrizione

Realizzata in TPU ad alte prestazioni, la tenuta per valvole a cartuccia VSS è utilizzata per applicazioni semi-statiche e semi-dinamiche e consente di ottenere, rispetto ai tradizionali sistemi multicomponente in NBR, vantaggi come:

- migliore resistenza a estrusione e abrasione grazie alle proprietà meccaniche del materiale
- maggior durata della guarnizione nel tempo
- assemblaggio semplificato per effetto del profilo simmetrico
- perfetta intercambiabilità con sedi standard o-ring + anello antiestrusione
- gestione semplificata delle scorte grazie all'utilizzo di un unico componente.

Dati tecnici

Pressione pulsante: 450 [bar] con punte fino a 600 [bar]

Temperatura: da - 35° C a + 100° C, con punte fino a + 110° C

Fluidi: olio e grassi minerali (v. tabella 3 a p. 14)

Montaggio

Il montaggio avviene in modo elastico in sede anulare. È importante eliminare gli spigoli vivi e le bave di lavorazione.

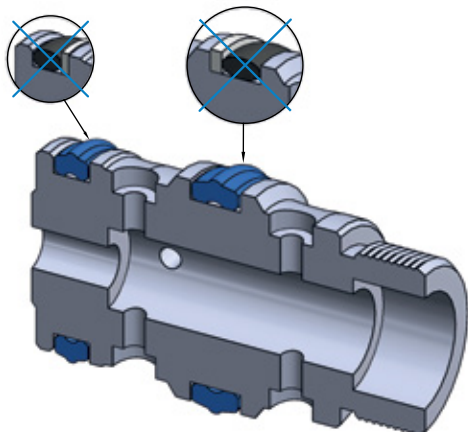

CARTRIDGE VALVES SEAL TYPE VSS

Description

Hydraulic seal for cartridge valves, made in high performance TPU, dedicated to semi-static and semi-dynamic applications.

This one-component seal allows to obtain considerable advantages over conventional multi-component systems in NBR:

- improved extrusion and abrasion resistance thanks to TPU's mechanical properties
- extended seal's life
- easier installation due to symmetrical profile
- perfect interchangeability with standard O-Ring + antiextrusion ring's groove
- cheaper stock handling due to unique component.

Technical data

Impulse pressure: 450 [bar] with peaks until 600 [bar]

Temperature: from - 35° C to + 100° C with peaks till + 110° C

Fluids: mineral oil and grease (see table 3, page 14)

Assembling

The installation is in anular groove and in elastic method. It is important to remove flashes or cutting edges to avoid damages.

Fig.41: Soluzione ARTIC SEALS: unica tenuta in materiale TPU poliestere ad alto modulo elastico, ottimo compression-set e alta resistenza all'abrasione, consente di sostituire i più comuni O-Ring + anello antiestrusione.

Pic.41: ARTIC SEALS solution: unique seals in polyester TPU with high elastic modulus, with an excellent compression set and high abrasion resistance, instead of the more common solution with O-ring + anti-extrusion ring.



VSS

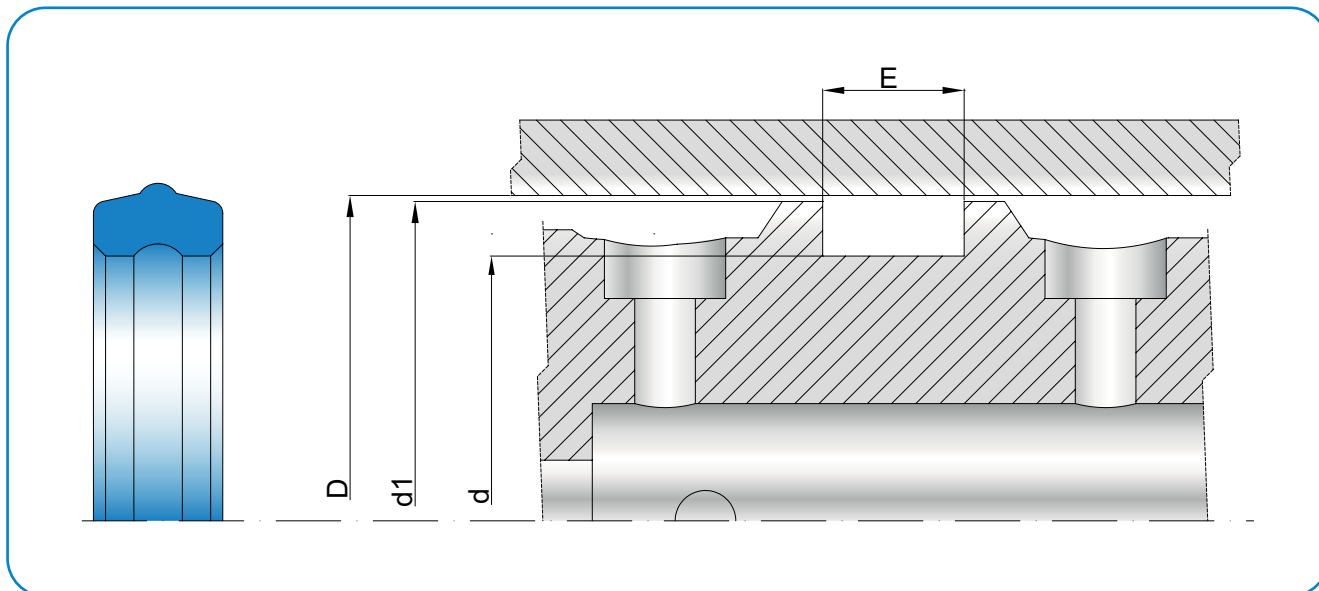
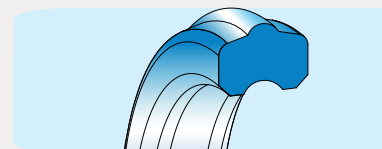

Inch Sizes

O-Ring Size	D _{H8}		d _{h9}		d _{1h9}		E _{+0,2}		ART / ITEM
	inch	mm	inch	mm	inch	mm	inch	mm	
010	0,374	9,50	0,264	6,71	0,372	9,45	0,138	3,51	VSS 0095 0067 035 Co
011	0,436	11,07	0,326	8,28	0,434	11,02	0,138	3,51	VSS 0110 0083 035 Co
012	0,499	12,67	0,389	9,88	0,497	12,62	0,138	3,51	VSS 0127 0099 035 Co
013	0,561	14,25	0,451	11,46	0,559	14,20	0,138	3,51	VSS 0142 0115 035 Co
014	0,624	15,85	0,514	13,06	0,622	15,80	0,138	3,51	VSS 0158 0131 035 Co
015	0,686	17,42	0,576	14,63	0,684	17,37	0,138	3,51	VSS 0174 0146 035 Co
016	0,749	19,02	0,639	16,23	0,747	18,97	0,138	3,51	VSS 0190 0162 035 Co
017	0,811	20,60	0,701	17,81	0,809	20,55	0,138	3,51	VSS 0206 0178 035 Co
018	0,874	22,20	0,764	19,41	0,872	22,15	0,138	3,51	VSS 0222 0194 035 Co
019	0,936	23,77	0,826	20,98	0,934	23,72	0,138	3,51	VSS 0237 0210 035 Co
020	0,999	25,37	0,889	22,58	0,997	25,32	0,138	3,51	VSS 0254 0226 035 Co

Nota: altre dimensioni non a catalogo a richiesta. Consultare il nostro ufficio tecnico.

Remark: please contact our technical dept. for further dimensions not included in the catalogue.

Tenute Statiche
Static Seals

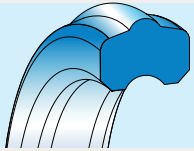

VSS

Metric Sizes

D _{H8} mm	d _{h9} mm	d _{1h9} mm	E _{+0,2} mm	ART / ITEM
8,20	5,30	8,15	3,50	VSS 0082 0053 035 Co
9,50	7,90	9,45	2,60	VSS 0095 0079 026 Co
10,20	8,60	10,15	2,60	VSS 0102 0086 026 Co
11,20	9,60	11,15	2,60	VSS 0112 0096 026 Co
11,80	10,30	11,75	2,60	VSS 0118 0103 026 Co
12,00	7,30	11,95	3,00	VSS 0120 0073 030 Co
12,00	8,60	11,95	2,40	VSS 0120 0086 024 Co
12,00	9,20	11,95	3,50	VSS 0120 0092 035 Co
12,50	10,90	12,45	2,80	VSS 0125 0109 028 Co
12,70	10,40	12,65	3,50	VSS 0127 0104 035 Co
13,00	10,10	12,95	3,50	VSS 0130 0101 035 Co
14,00	11,10	13,95	3,50	VSS 0140 0111 035 Co
14,25	11,46	14,20	2,50	VSS 0142 0115 025 Co
15,00	12,10	14,95	3,50	VSS 0150 0121 035 Co
15,85	13,06	15,80	2,50	VSS 0158 0131 025 Co
16,70	13,80	16,65	2,50	VSS 0167 0138 025 Co
17,40	14,60	17,35	2,50	VSS 0174 0146 025 Co
18,30	15,40	18,25	2,50	VSS 0183 0154 025 Co

D _{H8} mm	d _{h9} mm	d _{1h9} mm	E _{+0,2} mm	ART / ITEM
18,60	15,70	18,55	3,30	VSS 0186 0157 033 Co
19,00	16,20	18,95	2,50	VSS 0190 0162 025 Co
19,80	16,90	19,75	2,50	VSS 0198 0169 025 Co
20,00	17,20	19,95	3,50	VSS 0200 0172 035 Co
22,00	19,40	21,95	4,50	VSS 0220 0194 045 Co
22,30	17,50	22,25	3,20	VSS 0223 0175 032 Co
23,50	20,60	23,45	3,50	VSS 0235 0206 035 Co
24,00	21,40	23,95	4,50	VSS 0240 0214 045 Co
27,20	24,40	27,15	3,50	VSS 0272 0244 035 Co
28,50	25,80	28,45	3,50	VSS 0285 0258 035 Co
30,00	27,10	29,95	3,50	VSS 0300 0271 035 Co
32,00	29,20	31,95	3,50	VSS 0320 0292 035 Co
33,40	30,50	33,35	3,50	VSS 0334 0305 035 Co
34,00	31,20	33,95	3,50	VSS 0340 0312 035 Co
36,00	33,20	35,95	3,50	VSS 0360 0332 035 Co
36,50	32,30	36,45	3,50	VSS 0365 0320 035 Co
38,00	35,20	37,95	3,50	VSS 0380 0352 035 Co
50,80	47,80	50,75	3,50	VSS 0508 0478 035 Co

Nota: altre dimensioni non a catalogo a richiesta. Consultare il nostro ufficio tecnico.

Remark: please contact our technical dept. for further dimensions not included in the catalogue.



VSS

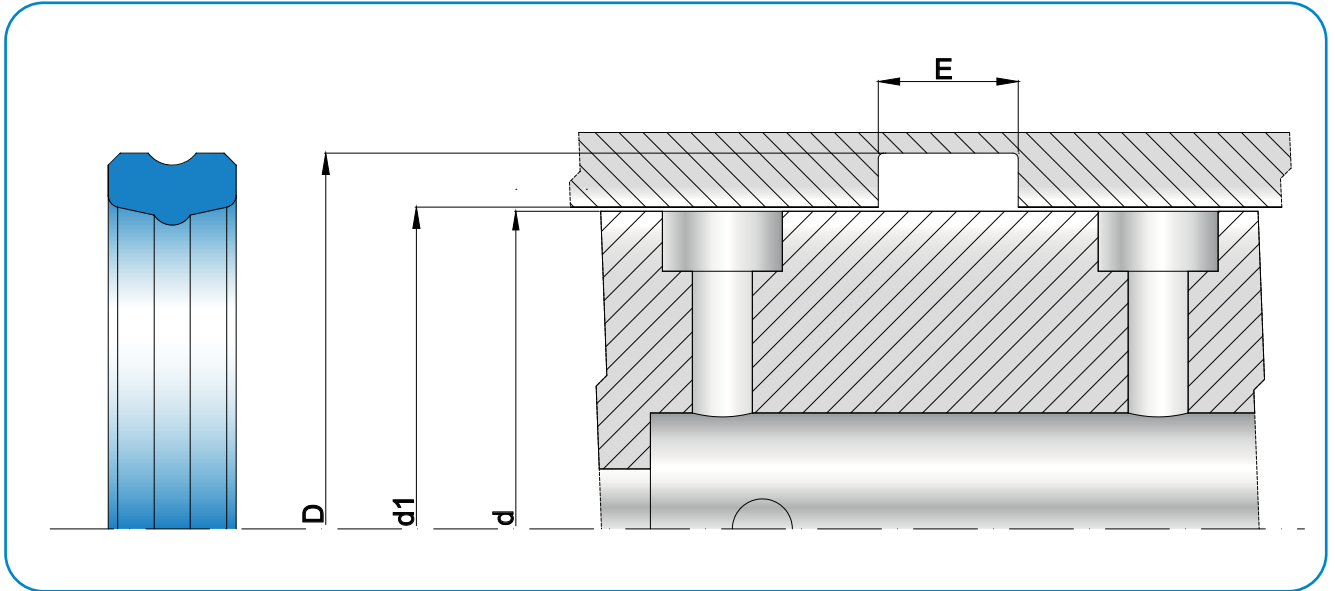
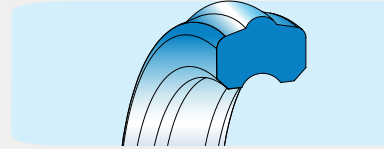

d_{H9} mm	D_{H8} mm	D_{1H8} mm	$E_{+0,2}$ mm	ART / ITEM				
7,10	10,10	7,15	2,50	VSS	0071	0100	025	Co
8,00	10,80	8,05	3,50	VSS	0080	0108	035	Co
9,60	11,20	9,65	2,30	VSS	0096	0112	023	Co
10,30	12,00	10,35	1,80	VSS	0103	0120	018	Co
17,50	22,30	17,55	3,70	VSS	0175	0223	037	Co
18,00	20,60	18,05	3,50	VSS	0180	0206	035	Co
19,00	23,80	19,05	3,70	VSS	0190	0238	037	Co
28,00	30,60	28,05	3,50	VSS	0280	0306	035	Co
28,50	31,50	28,55	2,50	VSS	0285	0315	025	Co
28,80	31,30	28,85	3,50	VSS	0288	0313	035	Co
32,40	38,00	32,45	5,20	VSS	0324	0380	052	Co
35,50	38,00	35,55	5,20	VSS	0355	0380	052	Co

Nota: altre dimensioni non a catalogo a richiesta. Consultare il nostro ufficio tecnico.

Remark: please contact our technical dept. for further dimensions not included in the catalogue.

Tenute Statiche
Static Seals

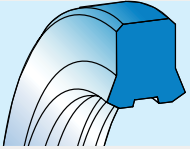

FSA

TENUTA PER FLANGE SAE TIPO FSA

Descrizione

In questi anni, la guarnizione tipo FSA (Flange SAE) ha trovato notevole impiego nelle applicazioni statiche in cui un normale o-ring in NBR non resiste a pressione e gioco di accoppiamento elevati. Lo speciale profilo, l'alto modulo elastico e un ottimo compression-set eliminano i problemi di estrusione e perdite nella flangiatura dei tubi.

Limiti d'impiego

Pressione: < 400 bar

Temperatura: da - 35° C a + 100° C, con punte fino a + 110° C

Fluidi: olio e grassi minerali, gas non aggressivi
(v. tabella 3 a p. 14)

Materiale

Il materiale utilizzato è un poliuretano tipo Co ad alto modulo elastico e a basso compression-set, con una elevata resistenza all'usura a 93 Shore A.
Codice materiale: Co

Vantaggi

Ottima resistenza ad abrasione ed estrusione.

Montaggio

È importante eliminare gli spigoli vivi e le bave nella sede ed eseguire uno smusso di invito per facilitare il montaggio che avviene in cava aperta.

FSA TYPE SAE FLANGE SEAL

Description

The FSA seal type (SAE Flange) has recently known a significant development in all static applications where a normal NBR O-ring would not resist to pressure and high coupling clearance. The specific profile and the high modulus of elasticity, together with an excellent compression-set, avoid extrusion and leakage problems in the tube flanging.

Technical data

Pressure: < 400 bar

Temperature: from - 35° C to + 100° C with peaks till + 110° C

Fluids: oil and mineral grease, non-aggressive gases
(see table 3, page 14)

Material

*The proposed material is a "Co" type polyurethane, with high elasticity modulus, low compression-set and high abrasion resistance. The hardness is 93 Shore A ± 2.
Compound reference: Co*

Advantages

Excellent abrasion and extrusion resistance.

Assembling

*It is important to remove flashes or cutting edges in the housing to avoid damages. It's also recommended to make a lead-in chamfer for easier assembling.
The installation in open housing is extremely simple.*



FSA

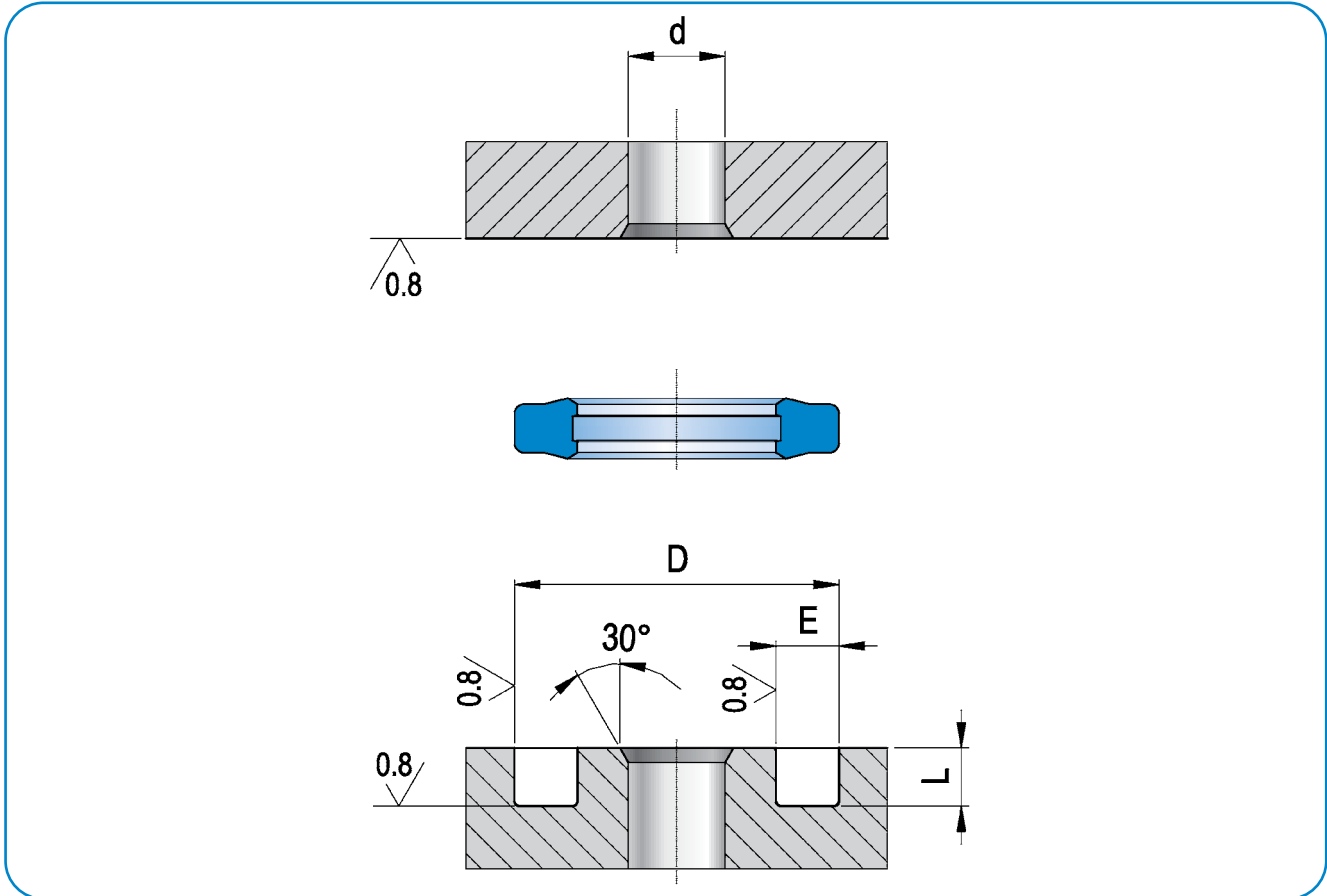
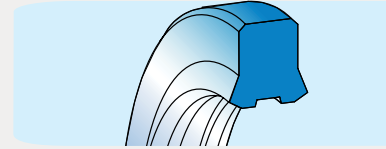

Tenute Statiche
Static Seals

INCH DIM.	d	D	E	L	ART / ITEM
			min - max		
1/2"	13,0	25,40 - 25,83	3,94 - 4,45	2,79 - 2,92	FSA 0500 Co
3/4"	19,0	31,75 - 31,88	3,94 - 4,45	2,79 - 2,92	FSA 0750 Co
1"	25,0	39,62 - 39,75	3,94 - 4,45	2,79 - 2,92	FSA 1000 Co
1" 1/4"	32,0	44,45 - 44,58	3,94 - 4,45	2,79 - 2,92	FSA 1250 Co
1" 1/2"	38,0	53,72 - 53,98	3,94 - 4,45	2,79 - 2,92	FSA 1500 Co
2"	51,0	63,25 - 63,50	3,94 - 4,45	2,79 - 2,92	FSA 2000 Co
2" 1/2"	63,0	76,45 - 76,70	3,94 - 4,45	2,79 - 2,92	FSA 2500 Co

Nota: altre dimensioni non a catalogo a richiesta. Consultare il nostro ufficio tecnico.

Remark: please contact our technical dept. for further dimensions not included in the catalogue.

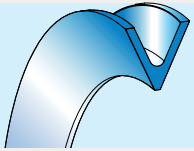

VRA

GUARNIZIONE A V TIPO VRA

Descrizione

La guarnizione tipo VRA è stata studiata per proteggere snodi, cuscinetti, bronzine, flange e tutte le parti meccaniche che lavorano in moto rotatorio o semi rotatorio. Realizzato in materiale Bo a bassa deformazione permanente, questo tipo di profilo impedisce ad acqua, fanghi e altre impurità di penetrare all'interno del componente. La vasta gamma di diametri facilita il costruttore nella scelta dimensionale.

Limiti d'impiego

Pressione: non essendo una guarnizione di tipo tradizionale, la pressione di esercizio è quella necessaria al mantenimento del grasso all'interno del sistema.

Temperatura: da - 40° C a + 90° C

Fluidi: olio e grassi minerali, gas non aggressivi (v. tabella 3 a p. 14)

Materiale

Poliuretano standard a 90 Shore A.

Codice materiale: Bo

Montaggio

È sufficiente ingrassare con grasso minerale le parti metalliche dove va alloggiata la guarnizione.

Eliminare spigoli e bave che danneggerebbero la tenuta.

VRA TYPE V-SEAL

Description

The VRA seal type has been conceived to protect joints, bearings, bronze bushes, flanges and all the mechanical parts in rotation or semi-rotation.

Made of Bo material, having a low permanent deformation, it prevents water mud and other impurities penetration.

The wide range of diameters helps the Manufacturer selection.

Technical data

Pressure: *it is not a traditional seal, the working pressure is therefore the one resulting from keeping the grease within the system.*

Temperature: *from - 40° C to + 90° C*

Fluid: *mineral oil and grease, non-aggressive gas
(see table 3, page 14)*

Material

Standard polyurethane at 90 Shore A.

Compound reference: Bo

Assembling

We recommend to lubricate the metal parts where the seal will be installed with mineral grease.

It is important to remove flashes or cutting edges otherwise they will reduce the sealing performance.



VRA

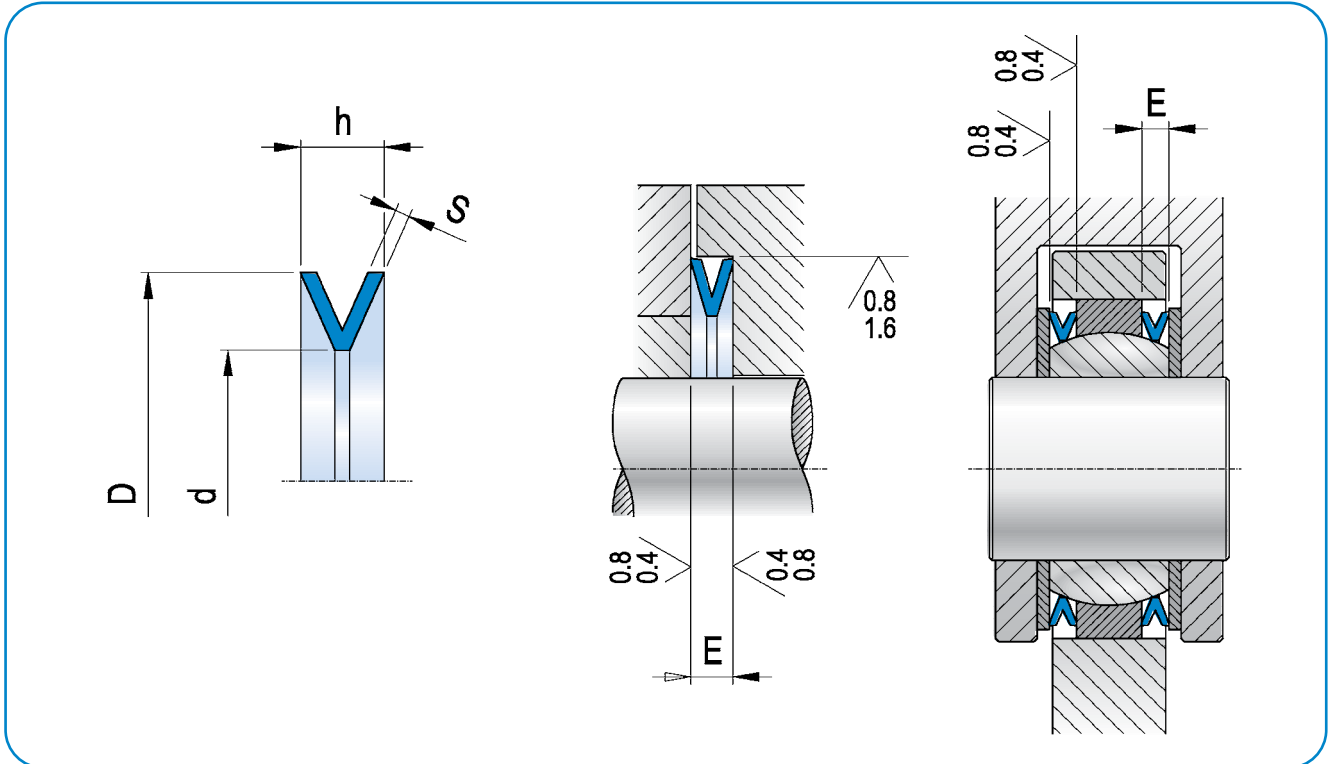
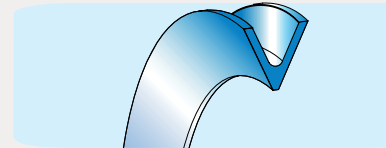

D	d	h	E _{+0,2}	S	ART / ITEM
27,5	22,5	4,0	2,0	0,75	VRA 0275 0225 040 Bo
38,5	31,0	4,5	2,0	0,75	VRA 0385 0310 045 Bo
43,0	36,0	5,0	2,0	0,75	VRA 0430 0360 050 Bo
51,0	42,0	6,0	2,5	0,80	VRA 0510 0420 060 Bo
57,5	47,5	7,0	3,0	1,00	VRA 0575 0475 070 Bo
59,0	50,5	5,0	2,5	1,00	VRA 0590 0505 050 Bo
64,0	54,0	7,0	3,5	1,00	VRA 0640 0540 070 Bo
71,0	59,0	7,0	3,5	1,00	VRA 0710 0590 070 Bo
73,0	59,0	7,0	3,5	1,30	VRA 0730 0590 070 Bo
80,0	65,0	7,0	3,5	1,00	VRA 0800 0650 070 Bo
86,0	70,0	9,0	4,0	1,00	VRA 0860 0700 090 Bo
86,0	71,0	9,0	4,0	1,00	VRA 0860 0710 090 Bo

D	d	h	E _{+0,2}	S	ART / ITEM
88,8	70,0	8,0	3,5	1,20	VRA 0888 0700 080 Bo
95,0	85,0	6,0	2,5	1,00	VRA 0950 0850 060 Bo
100,0	82,0	9,0	4,5	1,25	VRA 1000 0820 090 Bo
105,0	90,0	9,0	4,5	1,25	VRA 1050 0900 090 Bo
112,0	96,0	10,0	5,0	1,50	VRA 1120 0960 100 Bo
121,0	103,0	12,0	5,0	1,50	VRA 1210 1030 120 Bo
142,0	116,0	16,5	7,5	1,50	VRA 1420 1160 165 Bo
152,0	127,0	16,5	7,5	1,50	VRA 1520 1270 165 Bo
186,0	160,0	16,0	7,5	2,00	VRA 1860 1600 160 Bo

Nota: altre dimensioni non a catalogo a richiesta. Consultare il nostro ufficio tecnico.

Remark: please contact our technical dept. for further dimensions not included in the catalogue.

Tenute Statiche
Static Seals

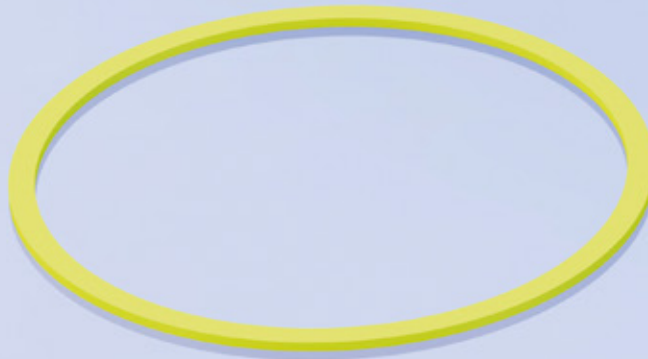



OR e antiestrusione

OR and Backup rings

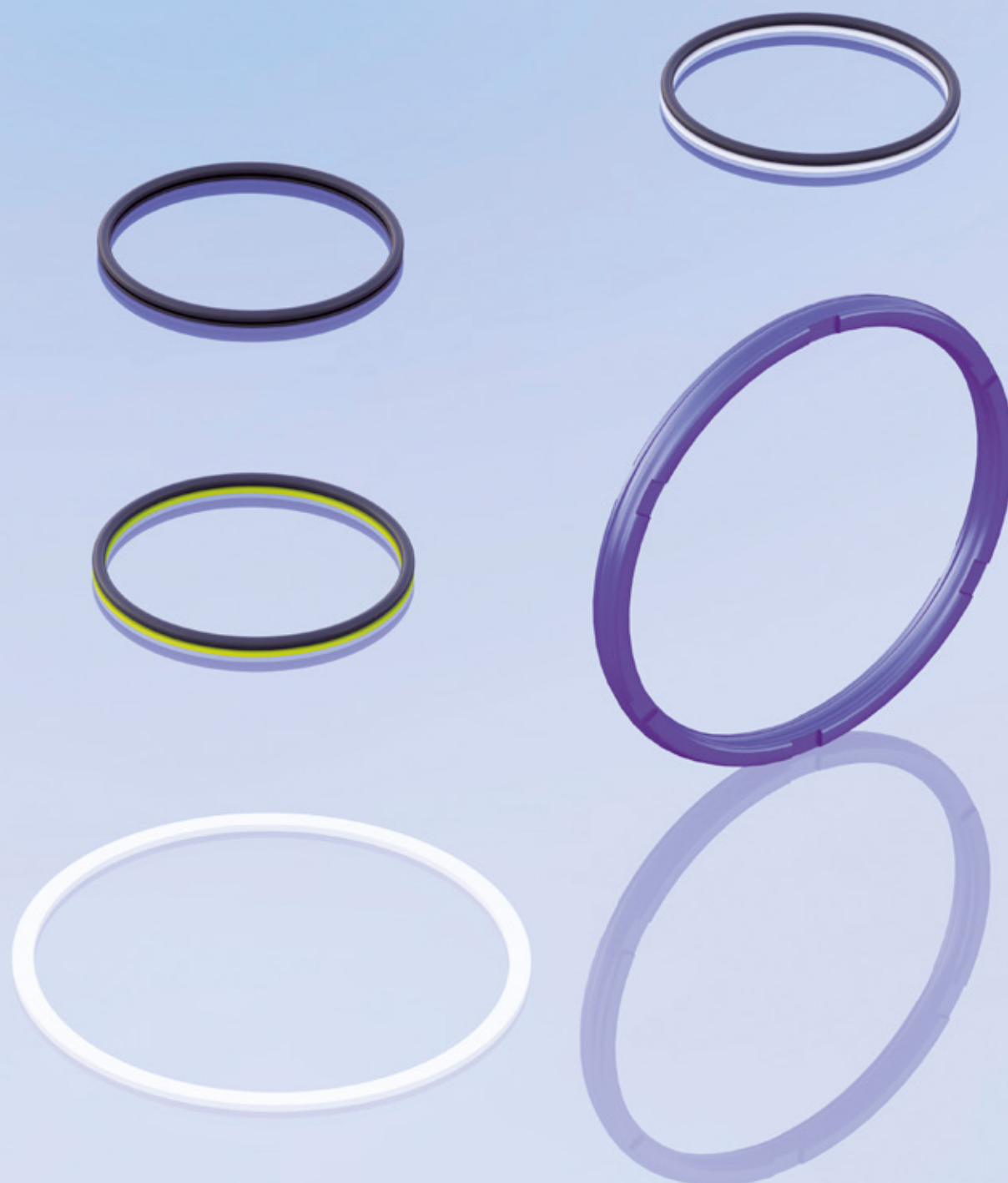

OR e Antiestrusione

OR and Backup Ring

Descrizione

L'o-ring, di forma toroidale, può essere utilizzato per applicazioni statiche e dinamiche e può essere fornito in varie mescole e durezza. Il campo delle sue applicazioni si è infatti notevolmente ampliato proprio grazie alla reperibilità di varie tipologie di materiali con differenti durezza. Anche se la forma toroidale è stata sostituita da altre tecnicamente più efficaci, la facilità di montaggio, la semplicità di esecuzione della sede e il costo contenuto fanno dell'o-ring la tenuta più utilizzata.

Description

The o-ring presents a toroidal shape and can be used for both static and dynamic applications and can be supplied in different compounds and hardness.



The availability on the market of various types of compounds and hardness has widened the application range.





Even if the toroidal shape has been replaced in some cases by more engineered shapes, the facility in the assembling, the simple groove construction and the limited cost made the O-ring the most used sealing.



Profili

Profile

O-RING / O-RING				
	OR	vedi specifiche mescole o-ring see specifications of o-ring compounds	Statica Static	240
	OR IN TPU	vedi specifiche mescole o-ring see specifications of o-ring compounds	Statica Static	242
	OR ANTIROLLING®	vedi specifiche mescole o-ring see specifications of o-ring compounds	Statica Static	248

ANELLI ANTIESTRUSIONE / BACK-UP RINGS												
Condizioni massime non simultanee / Maximum conditions (not combined)												
Profilo Profile	Ns Rif. Our Ref.	Temperatura Temperature C°	Pressione Pressure Bar	Velocità Speed m/s	Materiale Material	TPU	POM / PA	PTFE Bronze	NBR	TPE Resina PTFE Carbo. PTFE	Sezione Section	Pagina Page
	RAE/ MAE	-30 +120	-	< 0,8	TPE					●	Statica Static	250/264
	AKN	-30 +100	-	< 0,8	NBR				●		Statica Static	250
	AKC	-40 +200	-	< 0,8	PTFE					○	Statica Static	250
	AKW	-40 +200	-	< 0,8	PTFE					○	Statica Static	250
	AKS	-40 +200	-	< 0,8	PTFE					○	Statica Static	250

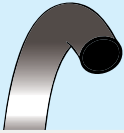

O-Rings

Dimensioni, tolleranze e qualità delle sedi

Le tabelle dimensionali indicano la sezione nominale dell'o-ring, il diametro interno e la sede. Le tolleranze di accoppiamento dipendono da pressione di esercizio, temperatura del fluido e durezza dell'elastomero.

Il grafico di fig. 33 indica orientativamente il gioco radiale in funzione di pressione e durezza.

La qualità della sede deve rientrare entro valori che impediscano all'o-ring di usurarsi nel leggero movimento che può avvenire durante cambi di pressioni o durante inversioni di ciclo. Il disegno di fig. 34 elenca le rugosità consigliate delle sedi di pistone e stelo.

Grooves dimensions, tolerance and quality

The o-ring's nominal section, diameter and groove are shown in the dimension charts. The coupling tolerances depend on the working pressure, on the fluid temperature and on the hardness of elastomer. In Fig. 33 is shown the approx. radial gap related to pressure and hardness.

The quality of the groove must remain within certain limits to prevent the o-ring wearing, while possible small movements may occur during pressure variation or cycle inversions.

In Fig. 34 the drawing indicates the suggested roughness for piston and rod grooves.

Fig. 42 - Pic. 42:

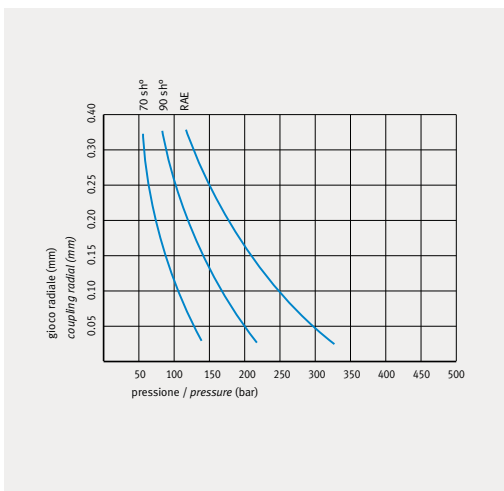
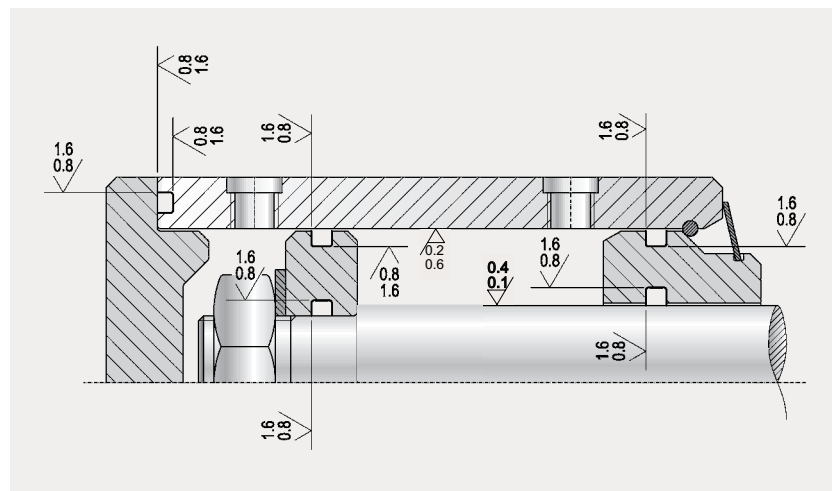
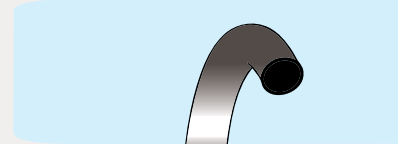

Fig. 43 - Pic. 43:





O-Rings



Material

Come indica la descrizione esistono varie mescole e durezza per l'o-ring.

Segue un elenco di alcuni tipi e il relativo utilizzo:

Mescole in NBR di durezza 70 Shore A standard e 90 Shore A su richiesta:

Mescole di impiego generico in oleodinamica e pneumatica.

Hanno una bassa deformazione permanente e resistono molto bene ai fluidi come olio minerale e vegetale, grassi e composti con acqua e glicole con temperatura inferiore a 60° C.

Il range di temperatura in esercizio è compreso tra -30° C e +100° C con punte per periodi brevi fino a 120° C.

Mescole in HNBR di durezza 70 Shore A standard e 75 Shore A su richiesta:

Mescole di base come l'NBR ma con doppio legame del componente butadiene.

Mescola idrogenata utilizzata per impieghi a temperature di 140° C (e per periodi brevi anche a 150° C dove la comune gomma in NBR non resiste), è compatibile con grassi, oli minerali e vegetali e si comporta molto bene all'ossidazione.

Mescole in EPDM di durezza 70 Shore A standard e 75 Shore A, su richiesta:

Mescole impiegate in presenza di acqua, acqua calda, fluido per freni, antigelo e glicoli con un range di temperatura compreso tra -40° C e +150° C.

Mescole in FKM di durezza 70 Shore A standard e 90 Shore A su richiesta:

Mescole in elastomero fluorurato utilizzate in applicazioni con temperature elevate e dove si richiede una inerzia chimica straordinaria. Impiegate a contatto con solventi aromatici, fluidi a base di esteri fosforici, lubrificanti sintetici e acidi concentrati, sono utilizzabili in un range di temperatura compreso tra i -15° C e +200° C.

Mescole in VMQ di durezza di 65/70 Shore A:

Mescole utilizzate nell'industria alimentare e medicale con ottimi risultati in acqua calda, ossigeno e ozono. Il range di temperature da -60° C a +220° C amplia il campo di applicazioni.

La tabella 1 a p. 12 riporta tutte le compatibilità con le mescole disponibili.

Material

There are, as indicated before, different compounds and hardness for O-rings.

Some of the materials and applications are listed hereafter.

NBR 70 Shore A standard compound, NBR90 Shore A on demand:

They can be used for hydraulic and pneumatic applications.

They present low compression-set and they have a very good resistance to fluids like mineral oil, vegetal

oil, greases and water-glycol compounds at temperatures not to exceeding 60° C.

The operating temperature ranges is from -30° C to +100° C, with short peaks up to 120° C.

HNBR 70 Shore A standard compound and HNBR75 Shore A on demand:

As the NBR they're basic compounds but with a double butadiene bond. It is a hydrogenated material and it can be used in applications where the normal rubber does not perform at temperatures of 140° C even with peaks of 150° C.

It is compatible with greases, mineral and vegetable oils has good behaviour against oxidation.

EPDM 70 Shore A standard compound and EPDM 75 Shore A on demand:

They can be used with water, hot water, fluids for brakes circuits, antifreeze fluid, glycols and the temperature range is from -40° C to +150° C.

FKM 75 Shore A standard compounds and FKM90 Shore A on demand:

Fluorinated elastomer compounds for high temperature applications and where high chemical inertia is requested.

They can be used in the contact with aromatic solvents, ester-phosphoric based fluids, synthetic lubricants and concentrated acids with temperature range from -15° C to +200° C.

VMQ 65/70 Shore A compounds:

They're mainly used in the food and medical industry. They give excellent results in hot water, oxygen and ozone.

The wide temperature range (from -60° C to +220° C) allows the use in several application.

For all the compounds compatibilities see table 1, page 12.

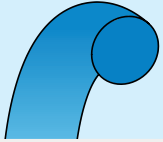

O-Ring in poliuretano

Polyurethane O-Rings

O-Ring in poliuretano

Descrizione

Le alte prestazioni dei TPU offrono un'eccellente resistenza all'estrusione, resistenza all'idrolisi, resilienza di rimbalzo molto forte e eccellente resistenza all'olio e all'abrasione. Dedicato per applicazioni statiche e dinamiche e altro in generale, dove gli O-Ring devono essere eseguiti in modo uniforme, anche in condizioni difficili. Questi materiali offrono molte proprietà fisiche eccezionali tra cui:

- Elevata resistenza all'usura
- Set di compressione basso
- Elevata resistenza all'estrusione
- Un ampio intervallo di funzionamento della temperatura

Size Programme

- sezione torica da 2,62 [mm] fino a 10 [mm];
- diametro interno da 10 [mm] fino a 250 [mm].

Condizioni di esercizio

Temperatura:

- da -40°C fino a +90 °C con materiale 90 Shore A
- da -35°C fino a +110 °C con materiale 94 Shore A

Pressione:

- 90 Shore A per pressione fino a 250 [Bar]
- 94 Shore A per pressione fino a 450 [Bar]
con punte fino a 500 [Bar]

Fluidi:

- Grassi e Oli minerali
- Idrocarburi alifatici
- Acqua fino a 50°C
- Grassi e Oli silconici
- Ossigeno, Azoto e ozono
- Fluidi a base glicole fino a 40°C

Polyurethane O-Rings

Description

The high performing of TPUs offer extremely high extrusion resistance, hydrolysis resistance, very strong rebound resilience and excellent oil and abrasion resistance. Dedicated for static and dynamic application and more in general where O-Rings need to perform consistently, even in harsh conditions. These materials offers many outstanding physical properties including:

- High wear resistance
- Low compression set
- High extrusion resistance
- A wide temperature operating range

Size Programme

- cross section from 2,62 [mm] up to 10 [mm];
- inside diameter from 10 [mm] up to 250 [mm].

Working Condition

Temperature:

- from -40°C up to +90 °C material 90 Shore A
- from -35°C up to +110 °C material 94 Shore A

Pressure:

- 90 Shore A for pressure up to 250 [Bar]
- 94 Shore A for pressure up to 450 [Bar]
with peaks up to 500 [Bar]

Material Compatibility

- Mineral Oils and grease
- Aliphatic hydrocarbons
- Water up to 50°C
- Silicone oil and grease
- Oxygen, nitrogen ,ozone
- Glycol based fluids up to 40°C



O-Ring in poliuretano Polyurethane O-Rings

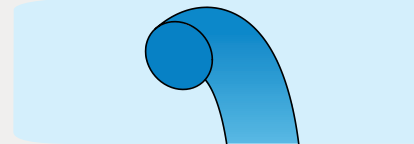

Punto di iniezione

Con lo scopo di ottenere O-Ring universali, che garantiscano perfetta tenuta in applicazioni statiche e dinamiche, sia in tenuta assiale che radiale ARTIC SEALS ha progettato O-Ring con punto di iniezione posizionato a 45° rispetto la sezione torica.

il punto di iniezione può essere come mostrato in figura di seguito:

Fig. 44 - Pic. 44:

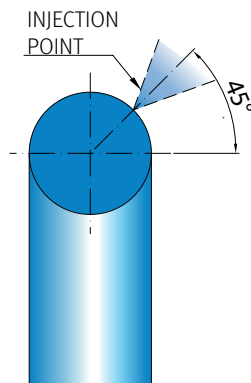

**Esterna per diametri:
External for diameter:**

10 [mm] - 150 [mm]

Injection Point

In order to obtain universal O-Rings , which grant a perfect sealing effect both in static and dynamic application which means radial or axial sealing ARTIC SEALS designed O-Ring with 45° injection point position.

the injection point will be as shown here in the picture below:

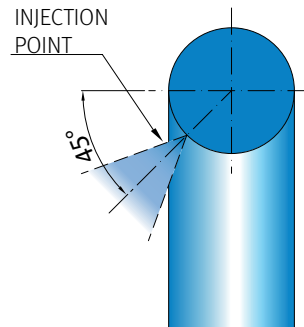

**Interna per diametri
Internal for diameter:**

150 [mm] - 250 [mm]

Advantages:

Fig. 45 - Pic. 45:

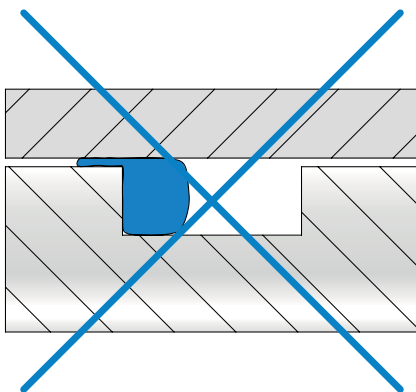

Perfettamente intercambiabile con tutte le dimensioni standard delle sedi sul mercato.

Perfectly interchangeable with all standard O-Ring's dimensions groove available on the market.

O-Ring in TPU evita l'estrusione anche in assenza di anello Backup.

TPU O-Rings avoid the extrusion without any antiextrusion rings.

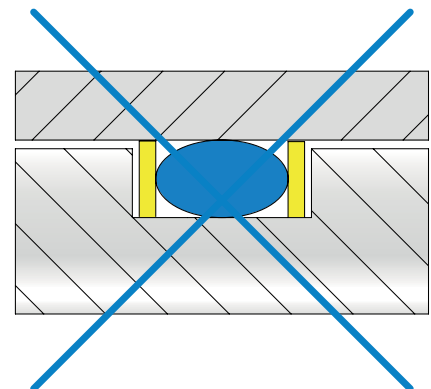

Installazione e gestione semplificata utilizzando solamente un particolare.

Easier assembly and more efficient stock handling due to use only one item

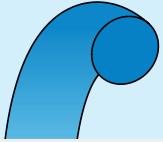

O-Ring in poliuretano Polyurethane O-Rings

TABELLE DIMENSIONI STANDARD INGLES-AMERICANE ENGLISH - AMERICAN STANDARD SIZE PROGRAM

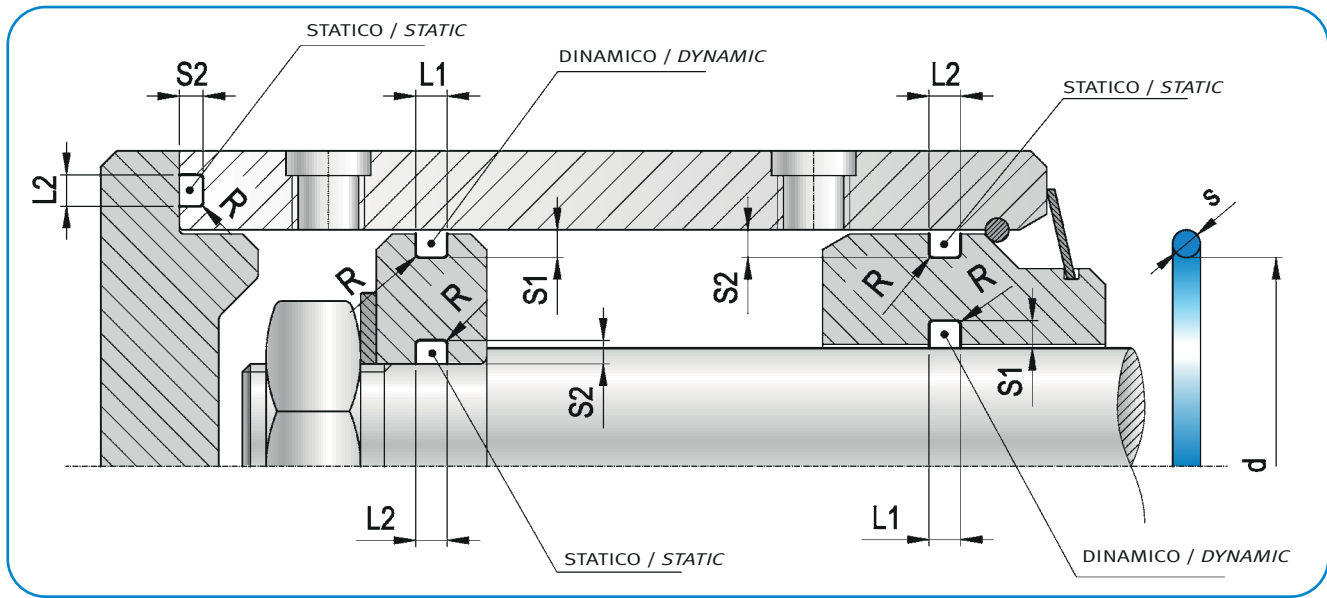

S	S1	L1	S2	L2	R
2,62 ± 0,09	2,25 ± 0,05	3,60 ± 0,2	2,00 ± 0,05	3,80 ± 0,2	0,4 ± 0,15

d	toll ±	AS-BS o-ring	ITA altro rif. alternative ref.	ARTICOLO / ITEM			
48,90	0,46	135	3193	OR	135	PPU	Co
50,47	0,47	136	3200	OR	136	PPU	Co
52,07	0,48	137	3206	OR	137	PPU	Co
53,65	0,18	138	3043	OR	138	PPU	Co
55,25	0,51	139	3218	OR	139	PPU	Co
56,82	0,52	140	3225	OR	140	PPU	Co
58,42	0,54	141	3231	OR	141	PPU	Co
60,00	0,55	142	3237	OR	142	PPU	Co
61,60	0,56	143	3243	OR	143	PPU	Co
63,17	0,58	144	3250	OR	144	PPU	Co



O-Ring in poliuretano

Polyurethane O-Rings

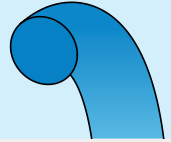

S	S1	L1	S2	L2	R
3,53 ± 0,1	3,10 ± 0,05	4,80 ± 0,2	2,70 ± 0,05	5,00 ± 0,2	0,5 ± 0,2

d	toll ±	AS-BS o-ring	ITA altro rif. alternative ref.	ARTICOLO / ITEM			
50,39	0,47	226	4200	OR	226	P PU	Co
53,57	0,50	227	4212	OR	227	P PU	Co
56,74	0,52	228	4225	OR	228	P PU	Co
59,92	0,54	229	4237	OR	229	P PU	Co
63,09	0,58	230	4250	OR	230	P PU	Co
66,27	0,59	231	4262	OR	231	P PU	Co
69,44	0,63	232	4275	OR	232	P PU	Co
72,62	0,64	233	4287	OR	233	P PU	Co
75,79	0,67	234	4300	OR	234	P PU	Co
78,97	0,69	236	4312	OR	236	P PU	Co

S	S1	L1	S2	L2	R
5,34 ± 0,13	4,70 ± 0,05	7,10 ± 0,2	4,30 ± 0,05	7,30 ± 0,2	0,6 ± 0,25

d	toll ±	AS-BS o-ring	ITA altro rif. alternative ref.	ARTICOLO / ITEM			
66,04	0,59	334	6262	OR	334	P PU	Co
69,22	0,63	335	6275	OR	335	P PU	Co
73,39	0,64	336	6287	OR	336	P PU	Co
75,57	0,67	337	6300	OR	337	P PU	Co
78,74	0,69	338	6312	OR	338	P PU	Co
81,92	0,71	339	6325	OR	339	P PU	Co
85,09	0,75	340	6337	OR	340	P PU	Co
88,27	0,77	341	6350	OR	341	P PU	Co
91,44	0,79	342	6362	OR	342	P PU	Co
94,62	0,81	343	6375	OR	343	P PU	Co

OR e antiestruzione
OR and Backup ring

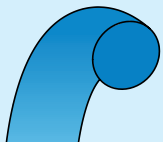

O-Ring in poliuretano Polyurethane O-Rings

**TABELLE DIMENSIONI METRICHE
METRIC STANDARD SIZE PROGRAM**

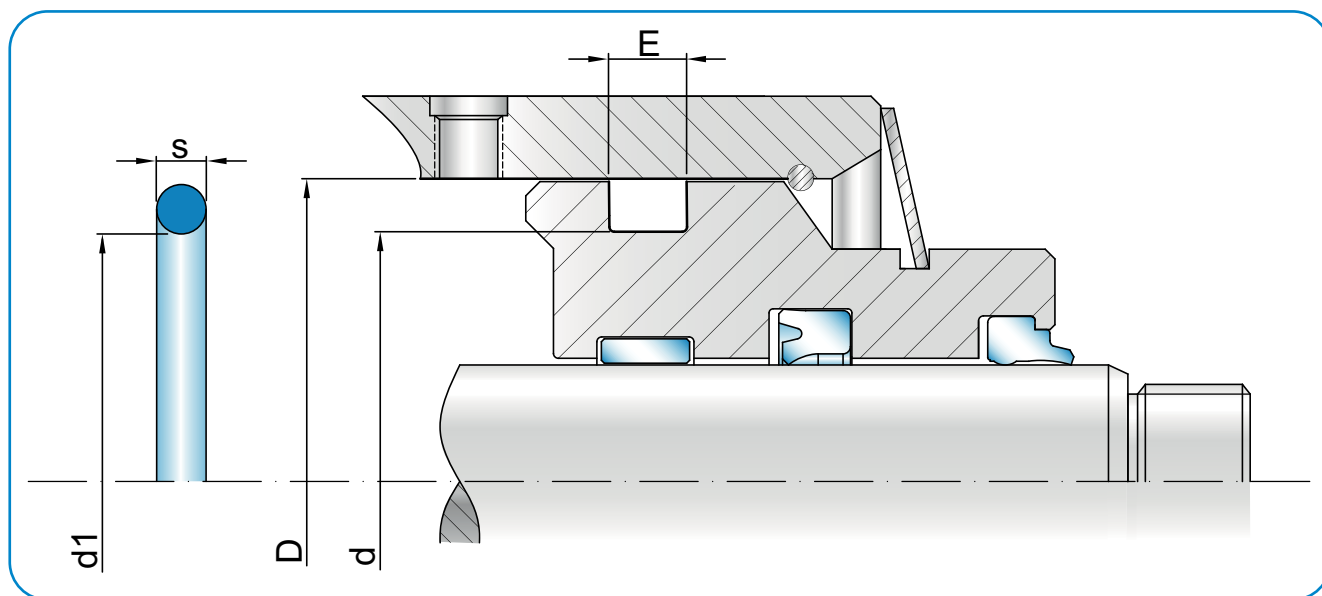

d_{H9}	D_{H8}	$E_{+0,2}$	d_1	s	ART/ITEM
50,0	55,0	3,7	49,5	3,0	OR 49,5 X 3 P PU Co
55,0	60,0	3,7	54,5	3,0	OR 54,5 X 3 P PU Co
60,0	65,0	3,7	59,5	3,0	OR 59,5 X 3 P PU Co
65,0	70,0	3,7	64,5	3,0	OR 64,5 X 3 P PU Co
70,0	75,0	3,7	69,5	3,0	OR 69,5 X 3 P PU Co
75,0	80,0	3,7	74,5	3,0	OR 74,5 X 3 P PU Co
80,0	85,0	3,7	79,5	3,0	OR 79,5 X 3 P PU Co
85,0	90,0	3,7	84,5	3,0	OR 84,5 X 3 P PU Co
90,0	95,0	3,7	89,5	3,0	OR 89,5 X 3 P PU Co
95,0	100,0	3,7	94,5	3,0	OR 94,5 X 3 P PU Co
100,0	105,0	3,7	99,5	3,0	OR 99,5 X 3 P PU Co
105,0	110,0	3,7	104,5	3,0	OR 104,5 X 3 P PU Co
110,0	115,0	3,7	109,5	3,0	OR 109,5 X 3 P PU Co
115,0	120,0	3,7	114,5	3,0	OR 114,5 X 3 P PU Co
120,0	125,0	3,7	119,5	3,0	OR 119,5 X 3 P PU Co
125,0	130,0	3,7	124,5	3,0	OR 124,5 X 3 P PU Co
130,0	135,0	3,7	129,5	3,0	OR 129,5 X 3 P PU Co
135,0	140,0	3,7	134,5	3,0	OR 134,5 X 3 P PU Co
140,0	145,0	3,7	139,5	3,0	OR 139,5 X 3 P PU Co
145,0	150,0	3,7	144,5	3,0	OR 144,5 X 3 P PU Co
35,0	45,0	6,4	34,2	5,7	OR 34,2 X 5,7 P PU Co
40,0	50,0	6,4	39,2	5,7	OR 39,2 X 5,7 P PU Co
45,0	55,0	6,4	44,2	5,7	OR 44,2 X 5,7 P PU Co
50,0	60,0	6,4	49,2	5,7	OR 49,2 X 5,7 P PU Co



O-Ring in poliuretano

Polyurethane O-Rings

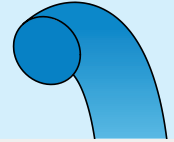

d _{H9}	D _{H8}	E _{+0,2}	d ₁	s	ART/ITEM
55,0	65,0	6,4	54,2	5,7	OR 54,2 X 5,7 P PU Co
60,0	70,0	6,4	59,2	5,7	OR 59,2 X 5,7 P PU Co
65,0	75,0	6,4	64,2	5,7	OR 64,2 X 5,7 P PU Co
70,0	80,0	6,4	69,2	5,7	OR 69,2 X 5,7 P PU Co
75,0	85,0	6,4	74,2	5,7	OR 74,2 X 5,7 P PU Co
80,0	90,0	6,4	79,2	5,7	OR 79,2 X 5,7 P PU Co
85,0	95,0	6,4	84,1	5,7	OR 84,1 X 5,7 P PU Co
90,0	100,0	6,4	89,1	5,7	OR 89,1 X 5,7 P PU Co
95,0	105,0	6,4	94,1	5,7	OR 94,1 X 5,7 P PU Co
100,0	110,0	6,4	99,1	5,7	OR 99,1 X 5,7 P PU Co
105,0	115,0	6,4	104,1	5,7	OR 104,1 X 5,7 P PU Co
110,0	120,0	6,4	109,1	5,7	OR 109,1 X 5,7 P PU Co
115,0	125,0	6,4	114,3	5,7	OR 114,3 X 5,7 P PU Co
120,0	130,0	6,4	119,3	5,7	OR 119,3 X 5,7 P PU Co
125,0	135,0	6,4	124,3	5,7	OR 124,3 X 5,7 P PU Co
130,0	140,0	6,4	129,3	5,7	OR 129,3 X 5,7 P PU Co
135,0	145,0	6,4	134,3	5,7	OR 134,3 X 5,7 P PU Co
140,0	150,0	6,4	139,3	5,7	OR 139,3 X 5,7 P PU Co
145,0	155,0	6,4	144,3	5,7	OR 144,3 X 5,7 P PU Co
150,0	160,0	6,4	149,3	5,7	OR 149,3 X 5,7 P PU Co
155,0	165,0	6,4	154,3	5,7	OR 154,3 X 5,7 P PU Co
160,0	170,0	6,4	159,3	5,7	OR 159,3 X 5,7 P PU Co
165,0	175,0	6,4	164,3	5,7	OR 164,3 X 5,7 P PU Co
170,0	180,0	6,4	169,3	5,7	OR 169,3 X 5,7 P PU Co
175,0	185,0	6,4	174,3	5,7	OR 174,3 X 5,7 P PU Co
180,0	190,0	6,4	179,3	5,7	OR 179,3 X 5,7 P PU Co
185,0	195,0	6,4	184,3	5,7	OR 184,3 X 5,7 P PU Co
190,0	200,0	6,4	189,3	5,7	OR 189,3 X 5,7 P PU Co
195,0	205,0	6,4	194,3	5,7	OR 194,3 X 5,7 P PU Co
200,0	210,0	6,4	199,3	5,7	OR 199,3 X 5,7 P PU Co
205,0	215,0	6,4	204,3	5,7	OR 204,3 X 5,7 P PU Co
210,0	220,0	6,4	209,3	5,7	OR 209,3 X 5,7 P PU Co
215,0	225,0	6,4	214,3	5,7	OR 214,3 X 5,7 P PU Co
220,0	230,0	6,4	219,3	5,7	OR 219,3 X 5,7 P PU Co
225,0	235,0	6,4	224,3	5,7	OR 224,3 X 5,7 P PU Co
230,0	240,0	6,4	229,3	5,7	OR 229,3 X 5,7 P PU Co
235,0	245,0	6,4	234,3	5,7	OR 234,3 X 5,7 P PU Co
240,0	250,0	6,4	239,3	5,7	OR 239,3 X 5,7 P PU Co

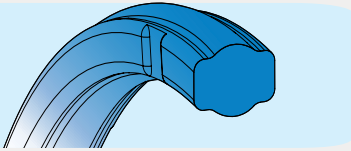

O-Ring Anti-Rolling®

PATENT PENDING
NO. MI2010A001639

Descrizione

La guarnizione O-ring Anti-Rolling® presenta un innovativo profilo studiato appositamente per superare i limiti tecnici spesso riscontrati nel classico o-ring. Grazie alle protusioni laterali, addossate alla sezione torica centrale, si realizza l'effetto antirotolamento dell'o-ring all'interno della sede e si previene ogni torsione della corda in fase di montaggio e di esercizio.

Inoltre, la sua particolare geometria evita l'utilizzo di anelli antiestrusione garantendo al tempo stesso la totale assenza di estrusione poiché la superficie di tenuta rimane costantemente distante dal fondo della sede.

I notches posizionati sulle protusioni evitano l'incollaggio dell'o-ring alle pareti della sede e fungono da sfiato in caso di residuo di pressione.

Materiali

L'o-ring Anti-Rolling® può essere realizzato in TPU, NBR, FKM e HNBR nelle diverse durezze disponibili. Il nostro ufficio tecnico studia soluzioni adeguate in base alle condizioni di esercizio specifiche dell'applicazione.

Description

The Anti-Rolling® O-Ring is an innovative seal technology designed to avoid the spiral failure mode of the standard O-Rings in radial applications.

The addition of axial protrusions prevents the seal from twisting in the groove during installation and reciprocating movement.

Additionally, the protrusions position the sealing surface away from the damaging effects of the extrusion gap, eliminating the need for separate anti-extrusion (back-up) rings.

The presence of notches, positioned on both protrusions, prevents bonding of O-Ring on the walls of the groove. They also realize ventil-effect in case of residual pressure.

Materiali

The Anti-Rolling® O-Ring could be produced in TPU, NBR, FKM, HNBR in a wide range of grades available. Please contact our technical department to study the appropriate solution according to the specific operating conditions of the application.

Fig.46 - Pic.46:

Perfettamente intercambiabile con la soluzione O-Ring + Anelli antiestrusione permette di utilizzare e tenere a stock un solo particolare.

Fully interchangeable with solution O-Ring+Backup Rings, more efficient stock manage due to use only one item.

La sua particolare geometria garantisce la totale assenza di estrusione in quanto la superficie di tenuta rimane distante dal fondo della sede.

The particular geometry ensures the complete absence of extrusion, because the the protrusions position the sealing surface away from the damaging effects of the extrusion gap.

La protusioni laterali addossate alla sezione torica centrale realizzano l'effetto Anti-Rotolamento, esse prevengono ogni tipo di torsione sia in fase di montaggio sia in fase di esercizio.

The lateral protusion leaned to the central toric section, realize the Anti-Rolling effect, they prevent any twisting both during intallation and exercise.

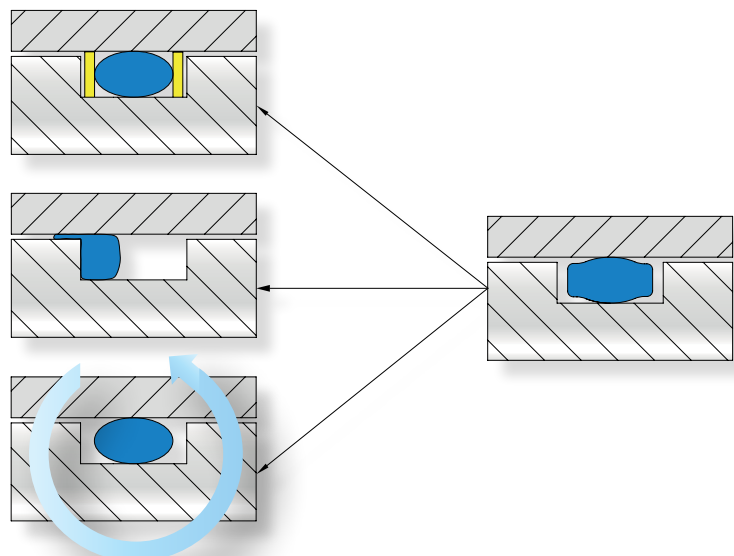



PATENT PENDING
NO. MI2010A001639

O-Ring Anti-Rolling®

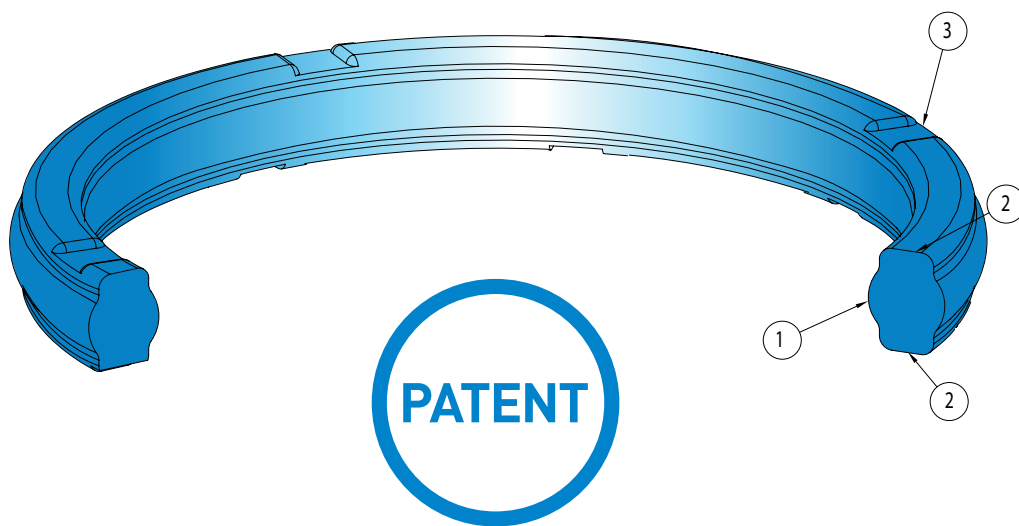
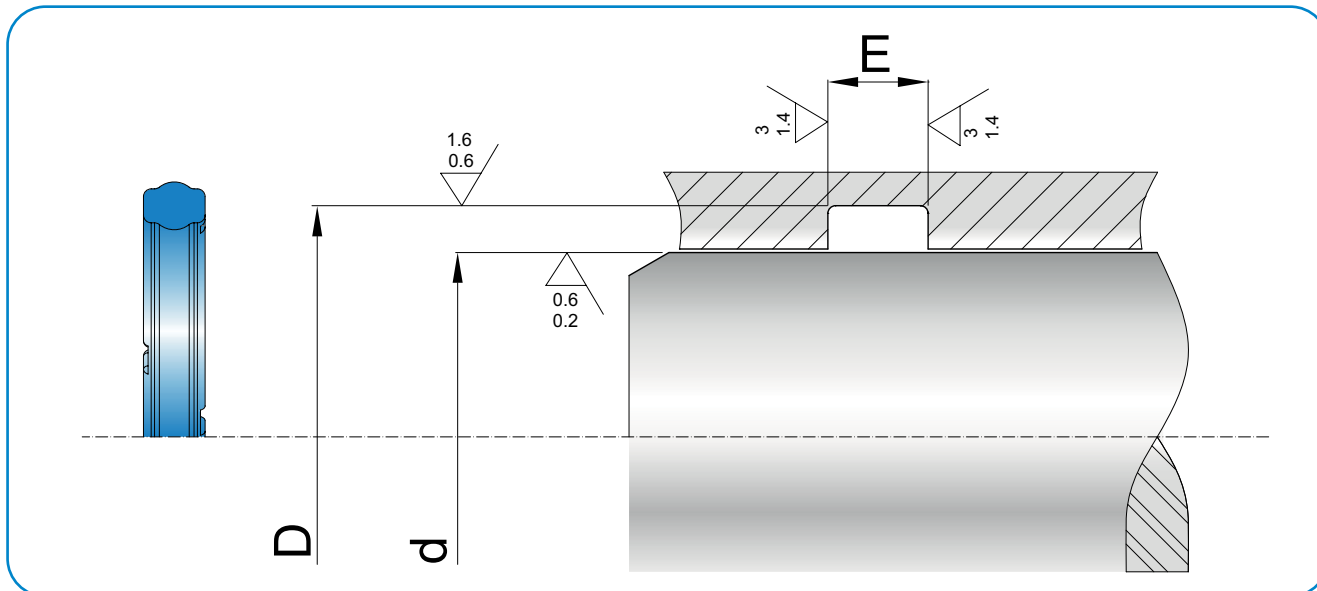
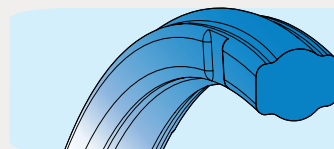

OR e antiestruzione
OR and Backup ring

Fig.47:
 1- sezione Torica
 2- protusioni laterali anti-rolling
 3- notches di sfiato e anti-incollaggio

Pic.47:
 1- toric central Section
 2- lateral Anti-Rolling Protusion
 3- notches Ventil-Effect and anti-bonding



Anelli antiestrusione

Back-up rings

ANELLI ANTIESTRUSIONE

Descrizione

Come già descritto, la tenuta con o-ring è la più semplice ed economica in condizioni di lavoro non gravose.

In presenza di pressioni più elevate il solo o-ring è insufficiente e bisogna montare o-ring con uno o due anelli antiestrusione per il semplice o doppio effetto realizzati in PTFE, NBR e TPE (termoplastico elastomero).

Dati tecnici

Pressione: <400 bar per il tipo RAE-MAE
<200 bar per il tipo AKN
<300 per i tipi AKC-AKS-AKW

Velocità: <1 m/s

Temperatura: da -20°C a 120°C per i tipi RAE
da -30°C a +100°C per i tipi AKN
da -20°C÷+200°C per i tipi AKC, AKS
e AKW compatibilmente con l'o-ring
montato.

Fluidi: fluidi idraulici a base minerale (v.
tabella 3 a p. 14)

Materiale

I materiali proposti sono:

- TPE (termoplastico elastomero) per il tipo RAEMAE
- NBR 90 Shore A per il tipo AKN
- PTFE per i tipi AKC-AKS-AKW.

Montaggio

Il montaggio avviene in cava chiusa con la sequenza anello antiestrusione e o-ring.

BACK UP RINGS

Description

As described above, the sealing with O-Ring is the simplest and the most economic solution for not heavy working conditions. But when there are high pressures the O-Ring alone is not enough. In this specific case we must mount O-ring with one or two anti-extrusion rings, for the simple or double effect. In the range of anti-extrusion rings there're different materials: PTFE, NBR and TPE (thermoplastic elastomer).

Technical data

Pressure: <400 bar for type RAE-MAE
<200 bar for type AKN
<300 bar for type AKC-AKS-AKW

Speed: < 1 m/s

Temperature: from -20°C to +120°C for type RAE
from -30°C to +100°C for type AKN
from -20°C to +200°C for type
AKC,AKS and AKW
depending on the O-Ring installed

Fluids: mineral hydraulic fluids
(see table 3, page 14)

Material

The different proposed materials are:

- TPE (thermoplastic elastomer) for type RAE-MAE
- NBR 90 Shore A for type AKN
- PTFE for types AKC-AKS-AKW

Assembling

The assembling is done in closed groove fitting the Anti-extrusion-ring before and the O-Ring after.



O-Ring + anello antiestrusione O-Ring + back-up ring

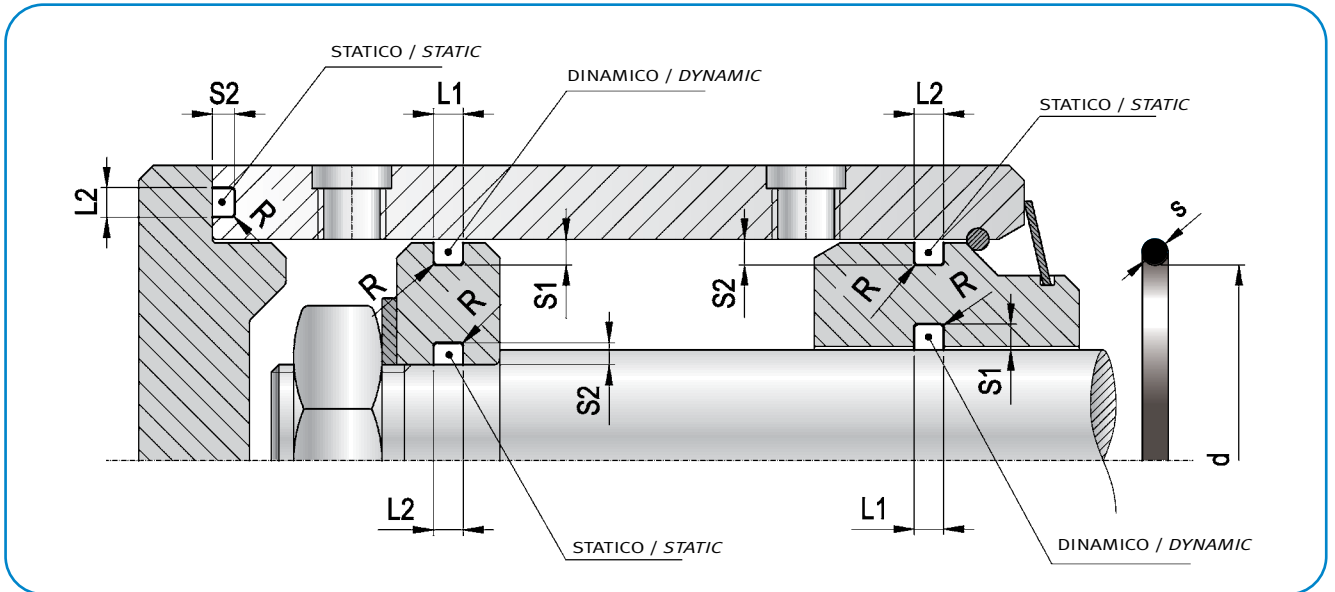
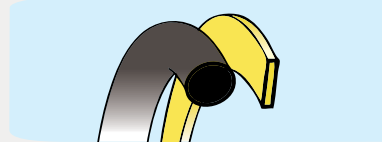

S sezione section	S1 sezione dinamica dynamic section	L1 sezione dinamica dynamic section	S2 sezione statica static section	L2 sezione statica static section	R raggio radius
1,78 ± 0,08	1,45 ± 0,05	2,40 ± 0,20	1,30 ± 0,05	2,60 ± 0,20	0,30 ± 0,10
2,62 ± 0,09	2,25 ± 0,05	3,60 ± 0,20	2,00 ± 0,05	3,80 ± 0,20	0,40 ± 0,15
3,53 ± 0,10	3,10 ± 0,05	4,80 ± 0,20	2,70 ± 0,05	5,00 ± 0,20	0,50 ± 0,20
5,34 ± 0,15	4,70 ± 0,05	7,10 ± 0,20	4,30 ± 0,05	7,30 ± 0,20	0,60 ± 0,25
6,99 ± 0,15	6,10 ± 0,05	9,50 ± 0,20	5,80 ± 0,05	9,70 ± 0,20	1,00 ± 0,30

DIMENSIONI SEDE GROOVE DIMENSION				S	h
		2,5	4,0	5,5	1,78
	3,5	5,0	6,5	2,62	2,25
	4,5	6,0	7,5	3,53	3,10
	7,0	9,0	10,5	5,34	4,70
	9,5	12,0	14,5	6,99	6,10

OR e antiestrusione
OR and Back-up ring

Tipi anelli antiestrusione

Antiextrusion rings types

RAE-MAE	AKS	AKC	AKW	AKN
TPE 55 shore D	PTFE	PTFE	PTFE	NBR 90 Shore A

Sez Corda O-Ring O-Ring CS	t				
	RAE	AKS	AKC	AKW	AKN
1,78	1,4	1,23	1,27	1,5	1,14
2,62	1,4	1,23	1,27	1,5	1,14
3,53	1,4	1,23	1,27	1,5	1,02
5,34	1,7	1,78	1,85	2,0	1,52
6,99	2,5	2,67	2,74	2,5	2,44

Esempio richiesta d'ordine

Per un o-ring 150:

Example for order request

For one o-ring 150:

Rif. anello antiestrusione Antiextrusion ring ref.		rif. O-Ring O-Ring ref.			Artic rif.
tipo type	materiale material	diametro diameter	rif. AS-BS AS-BS ref.	rif. ITA ITA ref.	Articolo / Item
RAE-MAE	TPE 55 Shore D	72,96 ± 0,64	150	3287	RAE 07296 00262 L1
AKS	PTFE	72,96 ± 0,64	150	3287	AKS 07296 00262 To
AKC	PTFE	72,96 ± 0,64	150	3287	AKC 07296 00262 To
AKW	PTFE	72,96 ± 0,64	150	3287	AKW 07296 00262 To
AKN	NBR 90 Shore A	72,96 ± 0,64	150	3287	AKN 07296 00262 No



O-Ring + RAE

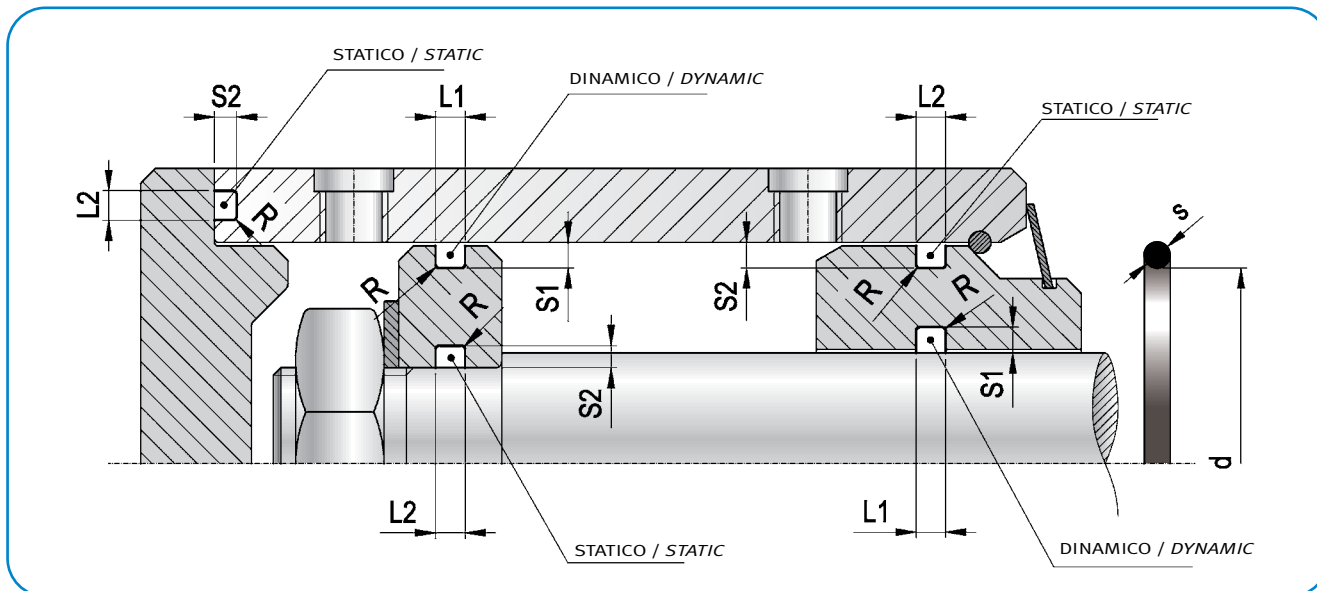
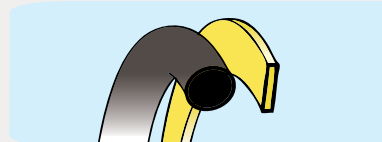

S	S1	L1	S2	L2	R
1,78 ± 0,08	1,45 ± 0,05	2,40 ± 0,20	1,30 ± 0,05	2,60 ± 0,20	0,30 ± 0,10

d	toll ±	AS-BS o-ring	ITA altro rif. alternative ref.	ARTICOLO / ITEM RAE (X 100)		
1,78	0,13	004	2007	RAE 00178	00178	L1
2,57	0,14	005	2010	RAE 00257	00178	L1
2,90	0,14	006	2012	RAE 00290	00178	L1
3,68	0,14	007	2015	RAE 00368	00178	L1
4,47	0,14	008	2018	RAE 00447	00178	L1
5,28	0,15	009	2019	RAE 00528	00178	L1
6,07	0,15	010	2025	RAE 00607	00178	L1
6,75	0,16	610	106	RAE 00675	00178	L1
7,65	0,16	011	2031	RAE 00765	00178	L1
8,73	0,17	611	108	RAE 00873	00178	L1
9,25	0,17	012	2037	RAE 00925	00178	L1
10,82	0,18	013	2043	RAE 01082	00178	L1
11,11	0,18	806	114	RAE 01111	00178	L1
12,42	0,19	014	2050	RAE 01242	00178	L1
14,00	0,20	015	2056	RAE 01400	00178	L1
15,60	0,20	016	2062	RAE 01560	00178	L1
17,17	0,21	017	2068	RAE 01717	00178	L1
18,77	0,22	018	2075	RAE 01877	00178	L1
20,35	0,23	019	2081	RAE 02035	00178	L1
21,95	0,24	020	2087	RAE 02195	00178	L1
23,52	0,24	021	2093	RAE 02352	00178	L1
25,12	0,26	022	2100	RAE 02512	00178	L1
26,07	0,28	023	2106	RAE 02607	00178	L1
28,30	0,29	024	2112	RAE 02830	00178	L1

OR e antiestruzione
OR and Backup ring

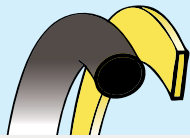

O-Ring + RAE

d	toll ±	AS-BS	ITA	ARTICOLO / ITEM			
		o-ring	altro rif. alternative ref.	RAE (X 100)			
29,87	0,29	025	2118	RAE	02987	00178	L1
31,47	0,31	026	2125	RAE	03147	00178	L1
33,05	0,32	027	2131	RAE	03305	00178	L1
34,65	0,33	028	2137	RAE	03465	00178	L1
37,82	0,37	029	2150	RAE	03782	00178	L1
41,00	0,39	030	2162	RAE	04100	00178	L1
44,17	0,42	031	2175	RAE	04417	00178	L1
47,35	0,44	032	2187	RAE	04735	00178	L1
50,52	0,47	033	2200	RAE	05052	00178	L1
53,70	0,50	034	2212	RAE	05370	00178	L1
56,87	0,52	035	2225	RAE	05687	00178	L1
60,05	0,55	036	2237	RAE	06005	00178	L1
63,22	0,58	037	2250	RAE	06322	00178	L1
66,40	0,59	038	2262	RAE	06640	00178	L1
69,57	0,63	039	2275	RAE	06957	00178	L1
72,75	0,64	040	2287	RAE	07275	00178	L1
75,92	0,67	041	2300	RAE	07592	00178	L1
82,27	0,71	042	2325	RAE	08227	00178	L1
88,62	0,77	043	2350	RAE	08862	00178	L1
94,97	0,81	044	2375	RAE	09497	00178	L1
101,32	0,87	045	2400	RAE	10132	00178	L1
107,67	0,91	046	2425	RAE	10767	00178	L1
114,02	0,95	047	2450	RAE	11402	00178	L1
120,37	1,00	048	2475	RAE	12037	00178	L1

S	S1	L1	S2	L2	R
2,62 ± 0,09	2,25 ± 0,05	3,60 ± 0,2	2,00 ± 0,05	3,80 ± 0,2	0,4 ± 0,15

d	toll ±	AS-BS	ITA	ARTICOLO / ITEM			
		o-ring	altro rif. alternative ref.	RAE (X 100)			
9,13	0,17	109	-	RAE	00913	00262	L1
9,19	0,17	110	3037	RAE	00919	00262	L1
9,92	0,17	613	112	RAE	00992	00262	L1
10,77	0,18	111	3043	RAE	01077	00262	L1
11,91	0,19	614	115	RAE	01191	00262	L1
12,37	0,19	112	3050	RAE	01237	00262	L1
13,10	0,19	615	117	RAE	01310	00262	L1
13,94	0,19	113	3056	RAE	01394	00262	L1
15,08	0,20	616	119	RAE	01508	00262	L1
15,54	0,20	114	3062	RAE	01554	00262	L1
15,88	0,20	809	121	RAE	01588	00262	L1
17,21	0,21	115	3068	RAE	01721	00262	L1



O-Ring + RAE

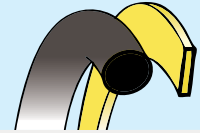

d	toll ±	AS-BS	ITA	ARTICOLO / ITEM			
		o-ring	altro rif. alternative ref.	RAE (X 100)			
17,86	0,21	617	123	RAE	01786	00262	L1
18,72	0,22	116	3075	RAE	01872	00262	L1
20,29	0,23	117	3081	RAE	02029	00262	L1
20,63	0,23	812	128	RAE	02063	00262	L1
21,89	0,23	118	3087	RAE	02189	00262	L1
22,22	0,24	813	130	RAE	02222	00262	L1
23,47	0,24	119	3093	RAE	02347	00262	L1
23,81	0,25	814	132	RAE	02381	00262	L1
25,07	0,26	120	3100	RAE	02507	00262	L1
26,64	0,28	121	3106	RAE	02664	00262	L1
28,24	0,29	122	3112	RAE	02824	00262	L1
29,82	0,29	123	3118	RAE	02982	00262	L1
31,42	0,31	124	3123	RAE	03142	00262	L1
32,99	0,32	125	3131	RAE	03299	00262	L1
34,60	0,33	126	3137	RAE	03460	00262	L1
36,14	0,35	127	3143	RAE	03614	00262	L1
37,77	0,37	128	3150	RAE	03777	00262	L1
39,34	0,38	129	3156	RAE	03934	00262	L1
40,95	0,39	130	3162	RAE	04095	00262	L1
42,52	0,40	131	3168	RAE	04252	00262	L1
44,12	0,42	132	3175	RAE	04412	00262	L1
45,69	0,43	133	3181	RAE	04569	00262	L1
47,30	0,44	134	3187	RAE	04730	00262	L1
48,90	0,46	135	3193	RAE	04890	00262	L1
50,47	0,47	136	3200	RAE	05047	00262	L1
52,07	0,48	137	3206	RAE	05207	00262	L1
53,65	0,50	138	3212	RAE	05365	00262	L1
55,25	0,51	139	3218	RAE	05525	00262	L1
56,82	0,52	140	3225	RAE	05682	00262	L1
58,42	0,54	141	3231	RAE	05842	00262	L1
60,00	0,55	142	3237	RAE	06000	00262	L1
61,60	0,56	143	3243	RAE	06160	00262	L1
63,17	0,58	144	3250	RAE	06317	00262	L1
64,77	0,58	145	3256	RAE	06477	00262	L1
66,35	0,59	146	3262	RAE	06635	00262	L1
67,95	0,61	147	3268	RAE	06795	00262	L1
69,52	0,63	148	3275	RAE	06952	00262	L1
71,12	0,64	149	3281	RAE	07112	00262	L1
72,96	0,64	150	3287	RAE	07296	00262	L1
75,87	0,67	151	3300	RAE	07587	00262	L1
82,22	0,71	152	3325	RAE	08222	00262	L1
88,57	0,77	153	3350	RAE	08857	00262	L1
94,92	0,81	154	3375	RAE	09492	00262	L1
101,27	0,87	155	3400	RAE	10127	00262	L1
107,62	0,91	156	3425	RAE	10762	00262	L1

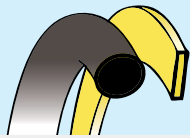

O-Ring + RAE

d	toll ±	AS-BS	ITA	ARTICOLO / ITEM			
		o-ring	altro rif. alternative ref.	RAE (X 100)			
113,97	0,95	157	3450	RAE	11397	00262	L1
120,33	1,00	158	3475	RAE	12033	00262	L1
126,67	1,05	159	3500	RAE	12667	00262	L1
133,00	1,10	160	3525	RAE	13300	00262	L1
139,38	1,13	161	3550	RAE	13938	00262	L1
145,72	1,20	162	3575	RAE	14572	00262	L1
152,07	1,24	163	3600	RAE	15207	00262	L1
158,43	1,27	164	3625	RAE	15843	00262	L1
164,78	1,31	165	3650	RAE	16478	00262	L1
171,13	1,38	166	3675	RAE	17113	00262	L1
177,84	1,41	167	3700	RAE	17784	00262	L1
183,83	1,44	168	3725	RAE	18383	00262	L1
190,18	1,51	169	3750	RAE	19018	00262	L1
196,53	1,55	170	3775	RAE	19653	00262	L1
202,88	1,59	171	3800	RAE	20288	00262	L1
209,23	1,63	172	3825	RAE	20923	00262	L1
215,58	1,67	173	3850	RAE	21558	00262	L1
221,93	1,71	174	3875	RAE	22193	00262	L1
228,28	1,75	175	3900	RAE	22828	00262	L1

S	S1	L1	S2	L2	R
3,53 ± 0,1	3,10 ± 0,05	4,80 ± 0,2	2,70 ± 0,05	5,00 ± 0,2	0,5 ± 0,2

d	toll ±	AS-BS	ITA	ARTICOLO / ITEM			
		o-ring	altro rif. alternative ref.	RAE (X 100)			
18,64	0,22	210	4075	RAE	01864	00353	L1
20,22	0,23	211	4081	RAE	02022	00353	L1
21,82	0,24	212	4087	RAE	02182	00353	L1
23,40	0,24	213	4093	RAE	02340	00353	L1
24,99	0,25	214	4100	RAE	02499	00353	L1
25,80	0,26	618	134	RAE	02580	00353	L1
26,58	0,28	215	4106	RAE	02658	00353	L1
28,17	0,29	216	4112	RAE	02817	00353	L1
29,75	0,29	217	4118	RAE	02975	00353	L1
31,34	0,31	218	4125	RAE	03134	00353	L1
32,92	0,32	219	4131	RAE	03292	00353	L1
34,52	0,34	220	4137	RAE	03452	00353	L1
36,09	0,35	221	4143	RAE	03609	00353	L1
37,69	0,37	222	4150	RAE	03769	00353	L1
39,69	0,38	824	144	RAE	03969	00353	L1
40,87	0,39	223	4162	RAE	04087	00353	L1
41,28	0,40	825	146	RAE	04128	00353	L1
42,86	0,41	826	147	RAE	04286	00353	L1



O-Ring + RAE

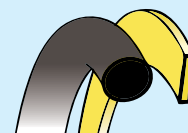

d	toll ±	AS-BS	ITA	ARTICOLO / ITEM			
		o-ring	altro rif. alternative ref.	RAE (X 100)			
44,04	0,42	224	4175	RAE	04404	00353	L1
44,45	0,42	827	149	RAE	04445	00353	L1
46,04	0,43	828	150	RAE	04604	00353	L1
47,22	0,44	225	4187	RAE	04722	00353	L1
47,63	0,45	829	152	RAE	04763	00353	L1
49,21	0,46	830	153	RAE	04921	00353	L1
50,39	0,47	226	4200	RAE	05039	00353	L1
50,80	0,47	831	155	RAE	05080	00353	L1
52,39	0,48	832	156	RAE	05239	00353	L1
53,57	0,50	227	4212	RAE	05357	00353	L1
53,98	0,50	833	158	RAE	05398	00353	L1
55,56	0,51	834	159	RAE	05556	00353	L1
56,74	0,52	228	4225	RAE	05674	00353	L1
57,15	0,54	835	161	RAE	05715	00353	L1
58,74	0,54	836	162	RAE	05874	00353	L1
59,92	0,54	229	4237	RAE	05992	00353	L1
60,33	0,55	837	164	RAE	06033	00353	L1
61,91	0,56	838	165	RAE	06191	00353	L1
63,09	0,58	230	4250	RAE	06309	00353	L1
63,50	0,58	839	167	RAE	06350	00353	L1
65,09	0,59	840	168	RAE	06509	00353	L1
66,27	0,59	231	4262	RAE	06627	00353	L1
66,68	0,59	841	170	RAE	06668	00353	L1
68,26	0,61	842	171	RAE	06826	00353	L1
69,44	0,63	232	4275	RAE	06944	00353	L1
69,85	0,63	843	173	RAE	06985	00353	L1
71,44	0,64	844	174	RAE	07144	00353	L1
72,62	0,64	233	4287	RAE	07262	00353	L1
73,03	0,66	845	176	RAE	07303	00353	L1
74,61	0,66	846	177	RAE	07461	00353	L1
75,79	0,67	234	4300	RAE	07579	00353	L1
78,97	0,69	235	4312	RAE	07897	00353	L1
82,14	0,71	236	4325	RAE	08214	00353	L1
85,32	0,75	237	4337	RAE	08532	00353	L1
88,49	0,77	238	4350	RAE	08849	00353	L1
91,67	0,79	239	4362	RAE	09167	00353	L1
94,84	0,81	240	4375	RAE	09484	00353	L1
98,02	0,84	241	4387	RAE	09802	00353	L1
101,19	0,87	242	4400	RAE	10119	00353	L1
104,37	0,89	243	4412	RAE	10437	00353	L1
107,54	0,91	244	4425	RAE	10754	00353	L1
110,72	0,93	245	4437	RAE	11072	00353	L1
113,89	0,95	246	4450	RAE	11389	00353	L1
117,07	0,97	247	4462	RAE	11707	00353	L1
120,24	1,00	248	4475	RAE	12024	00353	L1

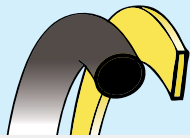

O-Ring + RAE

d	toll ±	AS-BS	ITA	ARTICOLO / ITEM			
		o-ring	altro rif. alternative ref.	RAE (X 100)			
123,42	1,03	249	4487	RAE	12342	00353	L1
126,59	1,05	250	4500	RAE	12659	00353	L1
129,77	1,08	251	4512	RAE	12977	00353	L1
132,94	1,10	252	4525	RAE	13294	00353	L1
136,12	1,13	253	4537	RAE	13612	00353	L1
139,29	1,13	254	4550	RAE	13929	00353	L1
142,47	1,17	255	4562	RAE	14247	00353	L1
145,64	1,20	256	4575	RAE	14564	00353	L1
148,82	1,20	257	4587	RAE	14882	00353	L1
151,99	1,24	258	4600	RAE	15199	00353	L1
158,34	1,27	259	4625	RAE	15834	00353	L1
164,69	1,31	260	4650	RAE	16469	00353	L1
171,04	1,38	261	4675	RAE	17104	00353	L1
177,39	1,41	262	4700	RAE	17739	00353	L1
183,74	1,44	263	4725	RAE	18374	00353	L1
190,09	1,51	264	4750	RAE	19009	00353	L1
196,44	1,55	265	4775	RAE	19644	00353	L1
202,79	1,59	266	4800	RAE	20279	00353	L1
209,14	1,63	267	4825	RAE	20914	00353	L1
215,49	1,67	268	4850	RAE	21549	00353	L1
221,84	1,71	269	4875	RAE	22184	00353	L1
228,19	1,75	270	4900	RAE	22819	00353	L1
234,54	1,79	271	4925	RAE	23454	00353	L1
240,89	1,83	272	4950	RAE	24089	00353	L1
247,24	1,88	273	4975	RAE	24724	00353	L1
253,59	1,93	274	41000	RAE	25359	00353	L1
266,29	2,02	275	41050	RAE	26629	00353	L1
278,99	2,08	276	41100	RAE	27899	00353	L1
291,69	2,21	277	41150	RAE	29169	00353	L1
304,39	2,25	278	41200	RAE	30439	00353	L1
329,79	2,43	279	41300	RAE	32979	00353	L1
355,19	2,62	280	41400	RAE	35519	00353	L1
380,59	2,76	281	41500	RAE	38059	00353	L1



O-Ring + RAE

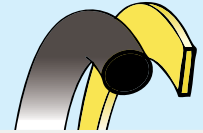

S	S1	L1	S2	L2	R
5,34 ± 0,13	4,70 ± 0,05	7,10 ± 0,2	4,30 ± 0,05	7,30 ± 0,2	0,6 ± 0,25

d	toll ±	AS-BS o-ring	ITA altro rif. alternative ref.	ARTICOLO / ITEM RAE (X 100)			
37,47	0,36	325	6150	RAE	03747	00534	L1
40,65	0,39	326	6162	RAE	04065	00534	L1
43,82	0,42	327	6175	RAE	04382	00534	L1
47,00	0,44	328	6187	RAE	04700	00534	L1
50,16	0,47	329	6200	RAE	05016	00534	L1
53,34	0,50	330	6212	RAE	05334	00534	L1
56,52	0,52	331	6225	RAE	05652	00534	L1
59,69	0,54	332	6237	RAE	05969	00534	L1
62,87	0,56	333	6250	RAE	06287	00534	L1
66,04	0,59	334	6262	RAE	06604	00534	L1
69,22	0,63	335	6275	RAE	06922	00534	L1
72,39	0,64	336	6287	RAE	07239	00534	L1
74,63	0,66	619	178	RAE	07463	00534	L1
75,57	0,67	337	6300	RAE	07557	00534	L1
78,74	0,69	338	6312	RAE	07874	00534	L1
79,77	0,69	620	181	RAE	07977	00534	L1
81,92	0,71	339	6325	RAE	08192	00534	L1
85,09	0,75	340	6337	RAE	08509	00534	L1
88,27	0,77	341	6350	RAE	08827	00534	L1
89,69	0,77	621	185	RAE	08969	00534	L1
91,44	0,79	342	6362	RAE	09144	00534	L1
94,62	0,81	343	6375	RAE	09462	00534	L1
97,79	0,84	344	6387	RAE	09779	00534	L1
100,00	0,87	622	189	RAE	10000	00534	L1
100,97	0,87	345	6400	RAE	10097	00534	L1
104,14	0,89	346	6412	RAE	10414	00534	L1
107,32	0,91	347	6425	RAE	10732	00534	L1
109,50	0,93	623	193	RAE	10950	00534	L1
110,05	0,93	348	6437	RAE	11005	00534	L1
113,67	0,95	349	6450	RAE	11367	00534	L1
116,84	0,97	350		RAE	11684	00534	L1
117,50	0,97	860	199	RAE	11750	00534	L1
120,02	1,00	351		RAE	12002	00534	L1
120,65	1,00	861	201	RAE	12007	00534	L1
123,20	1,03	352		RAE	12320	00534	L1
123,80	1,03	862	203	RAE	12380	00534	L1
126,37	1,05	353		RAE	12637	00534	L1
127,00	1,05	863	206	RAE	12700	00534	L1
129,54	1,08	354		RAE	12954	00534	L1
130,20	1,08	864	208	RAE	13020	00534	L1
132,72	1,10	355		RAE	13272	00534	L1
133,40	1,10	865	210	RAE	13340	00534	L1

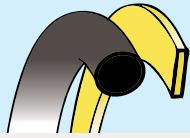

O-Ring + RAE

d	toll ±	AS-BS	ITA	ARTICOLO / ITEM			
		o-ring	altro rif. alternative ref.	RAE (X 100)			
135,90	1,10	356		RAE	13590	00534	L1
136,50	1,13	866	213	RAE	13650	00534	L1
139,07	1,13	357		RAE	13907	00534	L1
139,70	1,13	867	215	RAE	13970	00534	L1
142,24	1,17	358		RAE	14224	00534	L1
142,90	1,17	868	217	RAE	14290	00534	L1
145,42	1,20	359		RAE	14542	00534	L1
146,10	1,20	869	219	RAE	14610	00534	L1
148,60	1,20	360		RAE	14860	00534	L1
149,20	1,20	870	221	RAE	14920	00534	L1
151,77	1,24	361	6600	RAE	15177	00534	L1
158,12	1,27	362	6625	RAE	15812	00534	L1
164,47	1,31	363	6645	RAE	16447	00534	L1
170,82	1,38	364	6670	RAE	17082	00534	L1
177,17	1,41	365	6700	RAE	17717	00534	L1
183,52	1,44	366	6720	RAE	18352	00534	L1
189,87	1,48	367	6745	RAE	18987	00534	L1
196,22	1,55	368	6670	RAE	19622	00534	L1
202,57	1,59	369	6700	RAE	20257	00534	L1
208,92	1,63	370	6720	RAE	20892	00534	L1
215,27	1,67	371	6745	RAE	21527	00534	L1
221,62	1,71	372	6775	RAE	22162	00534	L1
227,97	1,75	373	6795	RAE	22797	00534	L1
234,32	1,79	374	6820	RAE	23432	00534	L1
240,67	1,83	375	6850	RAE	24067	00534	L1
247,02	1,88	376	6870	RAE	24702	00534	L1
253,37	1,93	377	6895	RAE	25337	00534	L1
266,07	2,02	378	6920	RAE	26607	00534	L1
278,77	2,08	379	6945	RAE	27877	00534	L1
291,47	2,21	380	6975	RAE	29147	00534	L1
304,17	2,25	381	6995	RAE	30417	00534	L1
329,57	2,43	382	61050	RAE	32957	00534	L1
354,97	2,56	383	61100	RAE	35497	00534	L1
380,37	2,76	384	61150	RAE	38037	00534	L1
405,26	2,91	385	61200	RAE	40526	00534	L1
430,66	3,07	386	61300	RAE	43066	00534	L1
456,06	3,22	387	61400	RAE	45606	00534	L1
481,40	3,37	388	61500	RAE	48140	00534	L1
506,80	3,54	389	61600	RAE	50680	00534	L1
532,20	3,72	390	61700	RAE	53220	00534	L1
557,60	3,81	391	61800	RAE	55760	00534	L1
582,68	4,05	392	61900	RAE	58268	00534	L1
608,08	4,13	393	62000	RAE	60808	00534	L1
633,48	4,34	394	62100	RAE	63348	00534	L1
658,88	4,46	395		RAE	65888	00534	L1



O-Ring + RAE

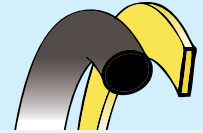

S	S1	L1	S2	L2	R
6,99 ± 0,15	6,1 ± 0,05	9,5 ± 0,2	5,80 ± 0,05	9,7 ± 0,2	1 ± 0,3

d	toll ±	AS-BS	ITA	ARTICOLO / ITEM			
		o-ring	altro rif. alternative ref.	RAE (X 100)			
113,67	0,95	425	4437	RAE	11376	00699	L1
114,70	0,95	624	197	RAE	11470	00699	L1
116,84	0,97	426	8462	RAE	11684	00699	L1
120,02	1,00	427	8475	RAE	12002	00699	L1
123,20	1,03	428	8487	RAE	12320	00699	L1
124,60	1,03	625	204	RAE	12460	00699	L1
126,37	1,05	429	8500	RAE	12637	00699	L1
129,54	1,08	430	8512	RAE	12954	00699	L1
132,72	1,10	431	8525	RAE	13272	00699	L1
134,50	1,10	626	211	RAE	13450	00699	L1
135,90	1,10	432	8537	RAE	13590	00699	L1
139,07	1,13	433	8550	RAE	13907	00699	L1
142,24	1,17	434	8562	RAE	14224	00699	L1
145,42	1,20	435	8575	RAE	14542	00699	L1
148,60	1,20	436	8587	RAE	14860	00699	L1
151,77	1,24	437	8600	RAE	15177	00699	L1
155,60	1,27	872	223	RAE	15560	00699	L1
158,12	1,27	438	8625	RAE	15812	00699	L1
159,50	1,27	627	225	RAE	15950	00699	L1
161,90	1,31	874	226	RAE	16190	00699	L1
164,47	1,31	439	8650	RAE	16447	00699	L1
166,70	1,34	628	228	RAE	16670	00699	L1
168,30	1,34	876	229	RAE	16830	00699	L1
170,82	1,38	440	8675	RAE	17082	00699	L1
174,60	1,38	878	231	RAE	17460	00699	L1
177,17	1,41	441	8700	RAE	17717	00699	L1
181,00	1,44	880	233	RAE	18100	00699	L1
183,52	1,44	442	8725	RAE	18352	00699	L1
187,30	1,48	882	235	RAE	18730	00699	L1
189,87	1,48	443	8750	RAE	18987	00699	L1
193,70	1,51	884	237	RAE	19370	00699	L1
196,22	1,55	444	8775	RAE	19622	00699	L1
200,00	1,55	886	239	RAE	20000	00699	L1
202,57	1,59	445	8800	RAE	20257	00699	L1
208,92	1,63	674	8825	RAE	20892	00699	L1
215,27	1,67	446	8850	RAE	21527	00699	L1
221,62	1,71	676	8875	RAE	22162	00699	L1
227,97	1,75	447	8900	RAE	22797	00699	L1
234,32	1,79	678	8925	RAE	23432	00699	L1
240,67	1,83	448	8950	RAE	24067	00699	L1
247,00	1,88	680	8975	RAE	24700	00699	L1
253,30	1,93	449	81000	RAE	25330	00699	L1

OR e antiestruzione
OR and Backup ring

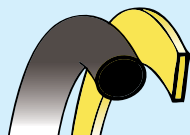

O-Ring + RAE

d	toll ±	AS-BS	ITA	ARTICOLO / ITEM			
		o-ring	altro rif. alternative ref.	RAE (X 100)			
259,70	1,98	682	81025	RAE	25970	00699	L1
266,07	2,02	450	81050	RAE	26607	00699	L1
272,40	2,08	684	81075	RAE	27240	00699	L1
278,77	2,08	451	81100	RAE	27877	00699	L1
285,10	2,14	686	81125	RAE	28510	00699	L1
291,47	2,21	452	81150	RAE	29147	00699	L1
297,80	2,21	688	81175	RAE	29780	00699	L1
304,17	2,25	453	81200	RAE	30417	00699	L1
316,87	2,37	454	81250	RAE	31687	00699	L1
329,57	2,43	455	81300	RAE	32957	00699	L1
342,27	2,49	456	81350	RAE	34227	00699	L1
354,97	2,56	457	81400	RAE	35497	00699	L1
367,67	2,68	458	81450	RAE	36767	00699	L1
380,37	2,76	459	81500	RAE	38037	00699	L1
393,07	2,84	460	81550	RAE	39307	00699	L1
405,26	2,91	461	81600	RAE	40526	00699	L1
417,96	2,99	462	81650	RAE	41796	00699	L1
430,66	3,07	463	81700	RAE	43066	00699	L1
443,36	3,15	464	81750	RAE	44336	00699	L1
456,06	3,22	465	81800	RAE	45606	00699	L1
468,76	3,30	466	81850	RAE	46876	00699	L1
481,46	3,37	467	81900	RAE	48146	00699	L1
494,16	3,45	468	81950	RAE	49416	00699	L1
506,86	3,54	469	82000	RAE	50686	00699	L1
532,26	3,72	470	82100	RAE	53226	00699	L1
557,66	3,81	471	82200	RAE	55766	00699	L1



O-Ring + RAE

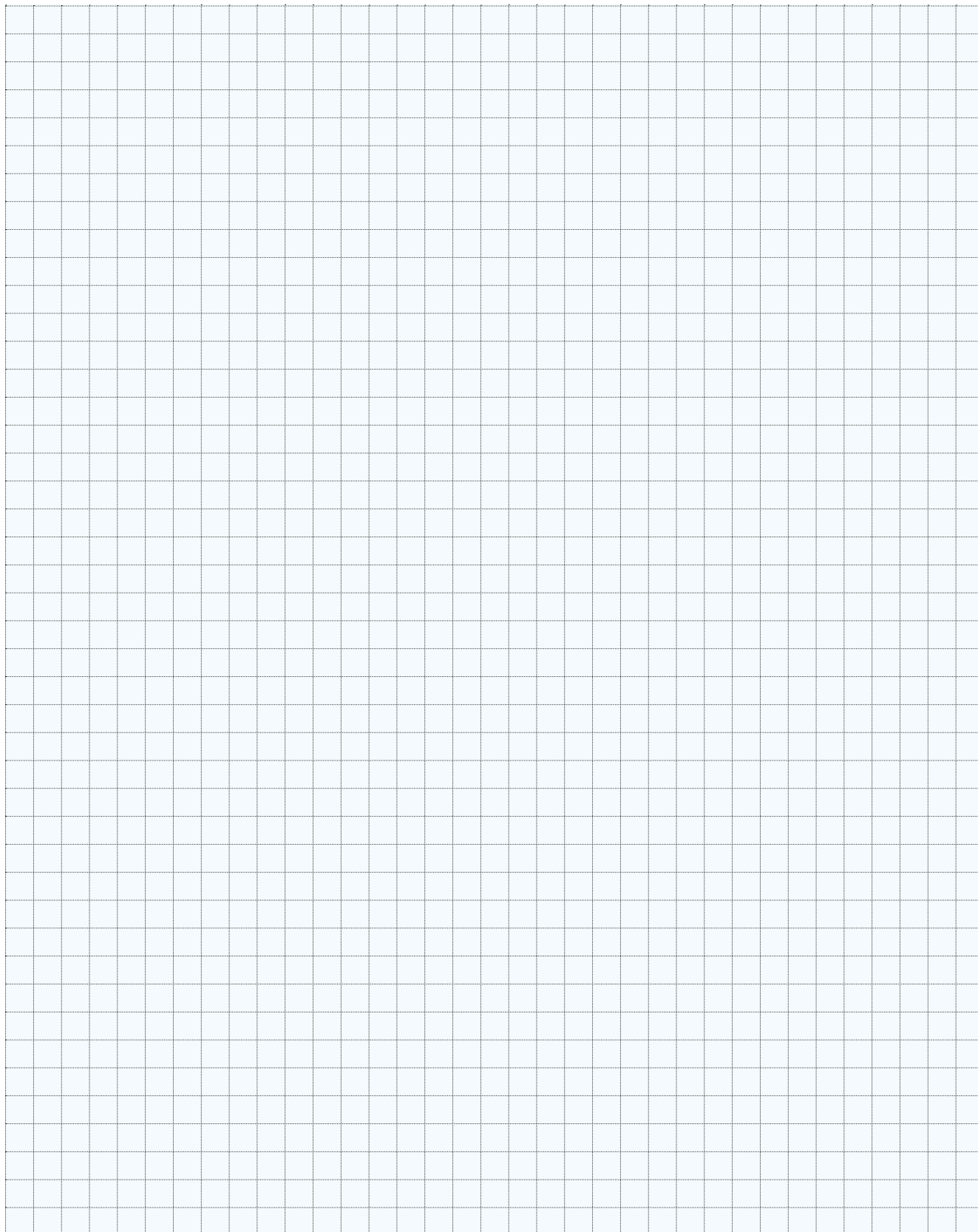
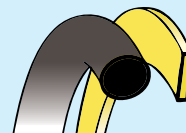

OR e antiestrusione
OR and Backup ring

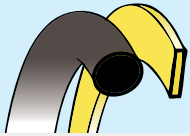

MAE (misura metriche / metric sizes)

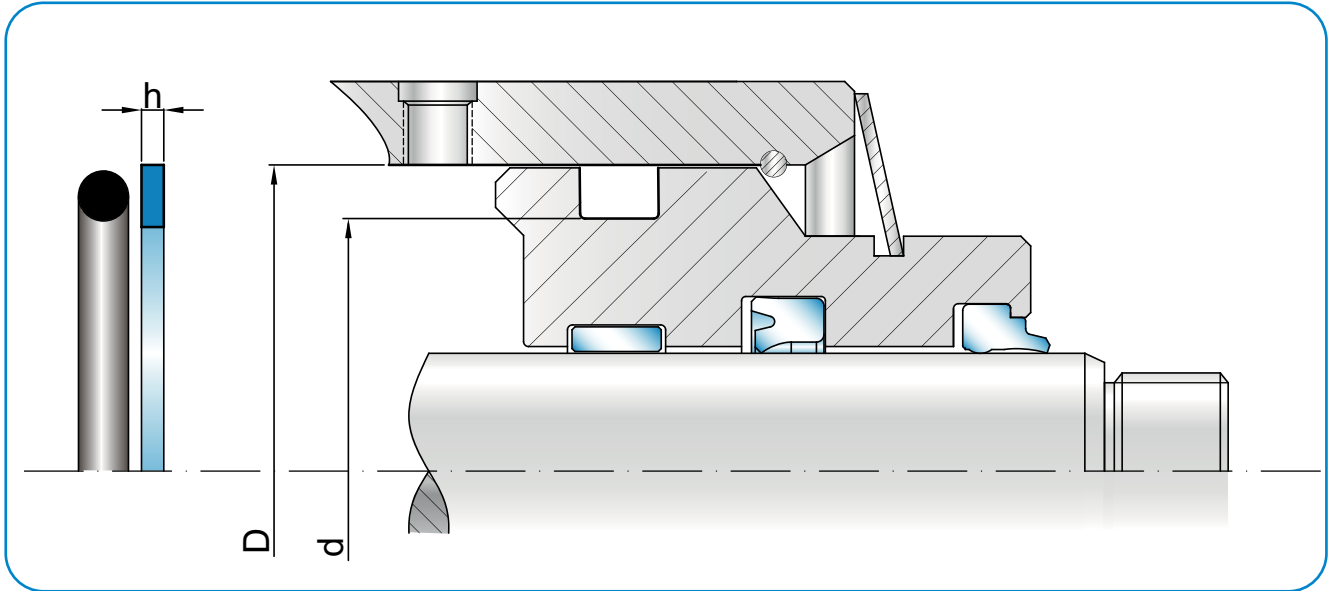

d_{H9}	D_{H8}	h	ART/ITEM
8,0	12,0	1,3	MAE 0080 0120 013 L1
9,0	13,0	1,3	MAE 0090 0130 013 L1
12,0	16,0	1,3	MAE 0120 0160 013 L1
10,0	14,0	1,3	MAE 0100 0140 013 L1
11,0	15,0	1,3	MAE 0110 0150 013 L1
12,0	16,0	1,3	MAE 0120 0160 013 L1
13,0	17,0	1,3	MAE 0130 0170 013 L1
14,0	18,0	1,3	MAE 0140 0180 013 L1
15,0	19,0	1,3	MAE 0150 0190 013 L1
16,0	20,0	1,3	MAE 0160 0200 013 L1
17,0	21,0	1,3	MAE 0170 0210 013 L1
18,0	22,0	1,3	MAE 0180 0220 013 L1
20,0	25,0	1,3	MAE 0200 0250 013 L1
23,0	28,0	1,3	MAE 0230 0280 013 L1
25,0	30,0	1,3	MAE 0250 0300 013 L1
27,0	32,0	1,3	MAE 0270 0320 013 L1
30,0	35,0	1,3	MAE 0300 0350 013 L1
30,0	40,0	1,7	MAE 0300 0400 017 L1
32,0	37,0	1,3	MAE 0320 0370 013 L1
33,0	38,0	1,3	MAE 0330 0380 013 L1
35,0	40,0	1,3	MAE 0350 0400 013 L1
37,0	42,0	1,3	MAE 0370 0420 013 L1
38,0	42,0	1,3	MAE 0380 0420 013 L1
40,0	45,0	1,3	MAE 0400 0450 013 L1
40,0	50,0	1,7	MAE 0400 0500 017 L1
43,0	48,0	1,3	MAE 0430 0480 013 L1
45,0	50,0	1,7	MAE 0450 0500 017 L1

d_{H9}	D_{H8}	h	ART/ITEM
50,0	55,0	1,3	MAE 0500 0550 013 L1
50,0	60,0	1,7	MAE 0500 0600 017 L1
53,0	63,0	1,7	MAE 0530 0630 017 L1
55,0	60,0	1,3	MAE 0550 0600 013 L1
55,0	65,0	1,7	MAE 0550 0650 017 L1
58,0	63,0	1,3	MAE 0580 0630 013 L1
60,0	65,0	1,3	MAE 0600 0650 013 L1
60,0	70,0	1,7	MAE 0600 0700 017 L1
63,0	68,0	1,3	MAE 0630 0680 013 L1
65,0	70,0	1,3	MAE 0650 0700 013 L1
65,0	75,0	1,7	MAE 0650 0750 017 L1
69,0	74,0	1,3	MAE 0690 0740 013 L1
70,0	75,0	1,3	MAE 0700 0750 013 L1
70,0	80,0	1,7	MAE 0700 0800 017 L1
71,4	80,0	2,0	MAE 0714 0800 020 L1
72,5	77,5	1,3	MAE 0725 0775 013 L1
72,5	82,5	1,7	MAE 0725 0825 017 L1
75,0	80,0	1,3	MAE 0750 0800 013 L1
75,0	85,0	1,7	MAE 0750 0850 013 L1
79,0	84,0	1,3	MAE 0790 0840 013 L1
80,0	85,0	1,3	MAE 0800 0850 013 L1
80,0	90,0	1,7	MAE 0800 0900 017 L1
85,0	90,0	1,3	MAE 0850 0900 013 L1
85,0	95,0	1,7	MAE 0850 0950 017 L1
90,0	95,0	1,3	MAE 0900 0950 013 L1
91,4	100,0	2,0	MAE 0914 1000 020 L1
94,0	99,0	1,3	MAE 0940 0990 013 L1

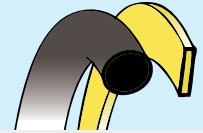
**(misure metriche / metric sizes) MAE**

d _{H9}	D _{H8}	h	ART/ITEM
90,0	100,0	1,7	MAE 0900 1000 017 L1
95,0	100,0	1,3	MAE 0950 1000 013 L1
95,0	105,0	1,7	MAE 0950 1050 017 L1
100,0	105,0	1,3	MAE 1000 1050 013 L1
100,0	110,0	1,7	MAE 1000 1100 017 L1
105,0	110,0	1,3	MAE 1050 1100 013 L1
105,0	115,0	1,7	MAE 1050 1150 017 L1
110,0	115,0	1,3	MAE 1100 1150 013 L1
110,0	120,0	1,7	MAE 1100 1200 017 L1
113,0	118,0	1,3	MAE 1130 1180 013 L1
115,0	120,0	1,3	MAE 1150 1200 013 L1
115,0	125,0	1,7	MAE 1150 1250 017 L1
120,0	125,0	1,3	MAE 1200 1250 013 L1
120,0	130,0	1,7	MAE 1200 1300 017 L1
125,0	130,0	1,3	MAE 1250 1300 013 L1
125,0	130,0	1,7	MAE 1250 1300 013 L1
125,0	135,0	1,7	MAE 1250 1350 017 L1
130,0	135,0	1,3	MAE 1300 1350 013 L1
130,0	140,0	1,7	MAE 1300 1400 017 L1
135,0	140,0	1,3	MAE 1350 1400 013 L1
135,0	145,0	1,7	MAE 1350 1450 017 L1
140,0	145,0	1,3	MAE 1400 1450 013 L1
140,0	150,0	1,7	MAE 1400 1500 017 L1
145,0	150,0	1,3	MAE 1450 1500 013 L1

d _{H9}	D _{H8}	h	ART/ITEM
145,0	155,0	1,7	MAE 1450 1550 017 L1
150,0	160,0	1,7	MAE 1500 1600 017 L1
155,0	165,0	1,7	MAE 1550 1650 017 L1
160,0	170,0	1,7	MAE 1600 1700 017 L1
165,0	175,0	1,7	MAE 1650 1750 017 L1
170,0	180,0	1,7	MAE 1700 1800 017 L1
175,0	185,0	1,7	MAE 1750 1850 017 L1
180,0	190,0	1,7	MAE 1800 1900 017 L1
185,0	195,0	1,7	MAE 1850 1950 017 L1
190,0	200,0	1,7	MAE 1900 2000 017 L1
195,0	205,0	1,7	MAE 1950 2050 017 L1
200,0	210,0	1,7	MAE 2000 2100 017 L1
210,0	220,0	1,7	MAE 2100 2200 017 L1
220,0	230,0	1,7	MAE 2200 2300 017 L1
230,0	240,0	1,7	MAE 2300 2400 017 L1
240,0	250,0	1,7	MAE 2400 2500 017 L1
245,0	255,0	1,7	MAE 2450 2550 017 L1
250,0	260,0	1,7	MAE 2500 2600 017 L1
270,0	280,0	1,7	MAE 2700 2800 017 L1
320,0	330,0	1,7	MAE 3200 3300 017 L1

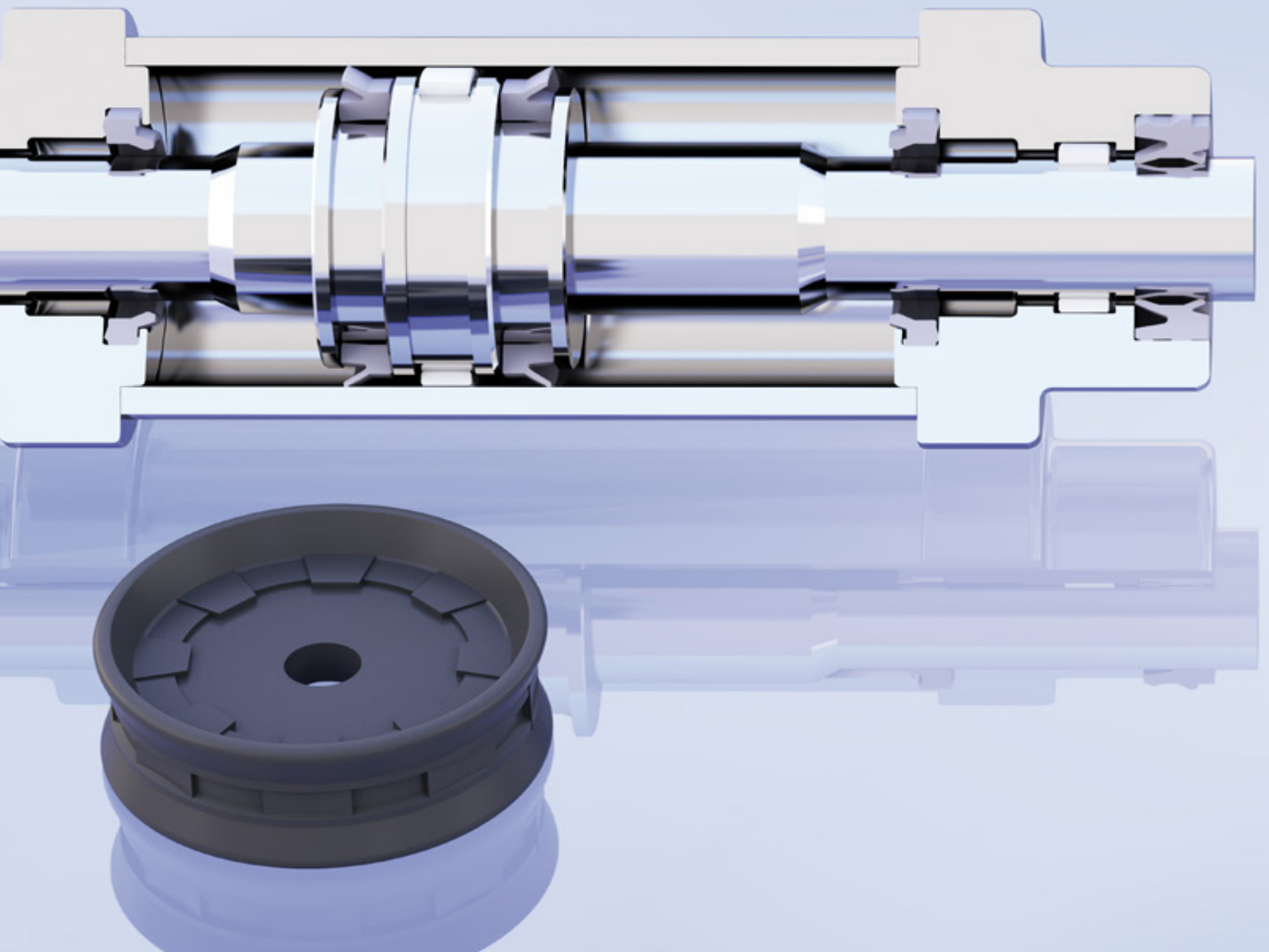



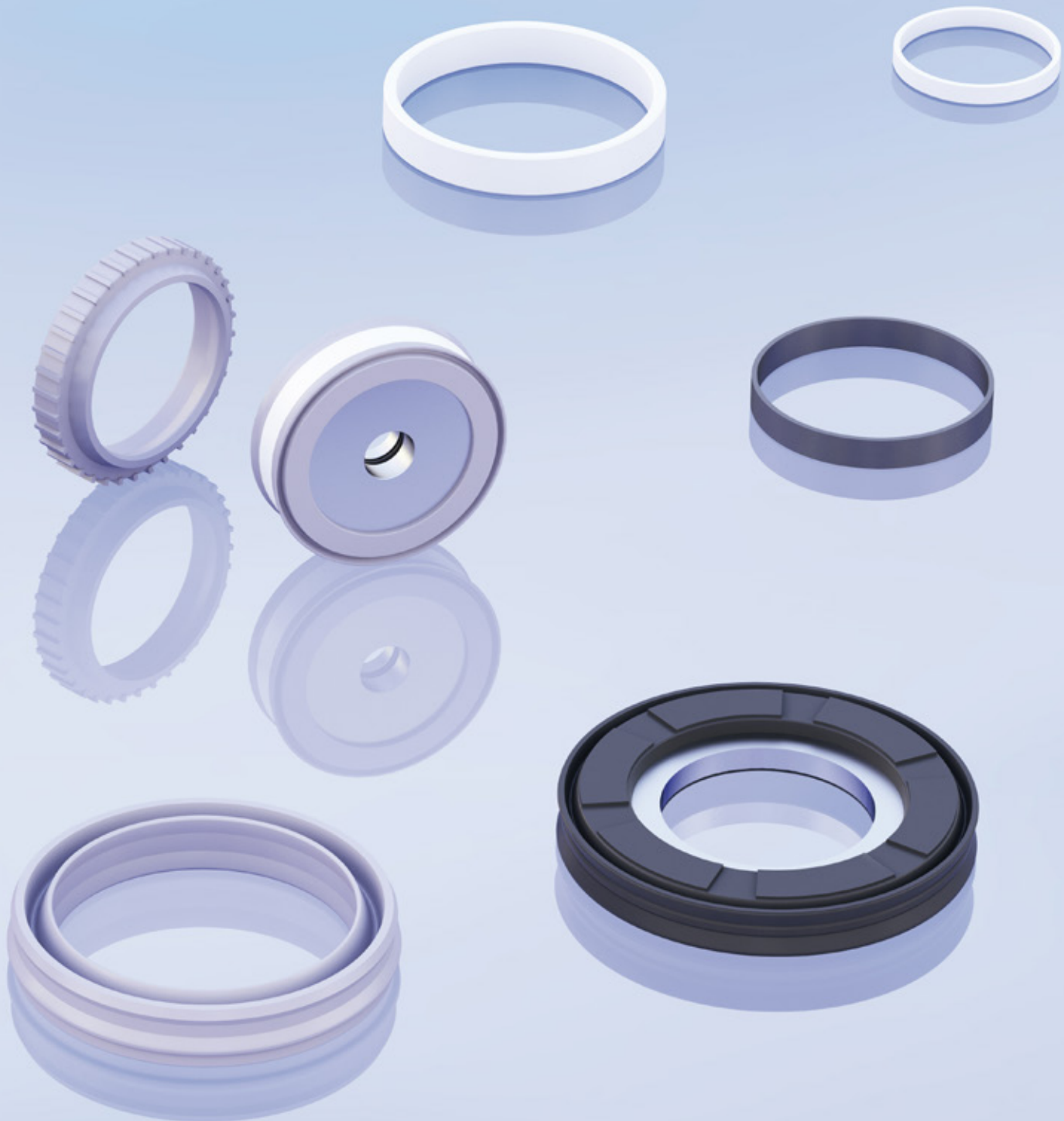

Sistemi di tenuta per pneumatica

Pneumatic sealing systems







Profili pneumatica: tenute stelo e pistone

Pneumatic profiles: rod and piston seals

GUARNIZIONI STELO / ROD SEALS										
Condizioni massime non simultanee / Maximum conditions (not combined)										
Profilo Profile	Ns Rif. Our Ref.	Temperatura Temperature C°	Pressione Pressure Bar	Velocità Speed m/s	Materiale Material	TPU POM / PA PTFE Bronze	NBR	TPE Resina PTFE Carbo. PTFE	Sezione Section	Pagina Page
	RSP	-40 +90	< 20	< 1	TPU	●			Pneumatica Pneumatic	274
	SRS	-40 +90	< 20	< 1	TPU	●			Pneumatica Pneumatic	276
	SRS/N	-30 +100	< 12	< 1	NBR		●		Pneumatica Pneumatic	278

GUARNIZIONI AMMORTIZZO / CUSHION SEALS										
	CSA	-40 +90	< 20	< 1	TPU	●			Pneumatica Pneumatic	280







GUARNIZIONI PISTONE / PISTON SEALS										
	PSP	-40 +90	< 20	< 1	TPU	●			Pneumatica Pneumatic	282
	MPS	-40 +90	< 20	< 1	TPU	●			Pneumatica Pneumatic	286
	MPS/2	-40 +90	20	< 1	TPU	●			Pneumatica Pneumatic	288
	MPM	-40 +90	< 20	< 1	POM NBR TPU	● ○ ●			Pneumatica Pneumatic	290
	SPS	-40 +90	< 20	< 1	TPU	●			Pneumatica Pneumatic	292
	SPS/N	-30 +100	< 12	< 1	NBR		●		Pneumatica Pneumatic	294
	PLF	-40 +90	< 20	< 1	TPU	●			Pneumatica Pneumatic	296
	MPP	-30 +100	< 20	< 1	NBR STEEL		●		Pneumatica Pneumatic	298
	MPC	-30 +100	< 20	< 1	NBR STEEL		●		Pneumatica Pneumatic	300
	PSN	-30 +110	< 250	< 4	Technopolymer NBR		●	○	Hydraulic / Pneumatic	302



Profili pneumatica: guide e raschiatori

Pneumatic profiles: wear rings and wiper

ANELLI DI GUIDA / WEAR RINGS											
<i>(sezione tecnica guide pag. 158 / wear rings technical section pag. 158)</i>											
Condizioni massime non simultanee / Maximum conditions (not combined)											
Profilo Profile	Ns Rif. Our Ref.	Temperatura Temperature C°	Pressione Pressure Bar	Velocità Speed m/s	Materiale Material	TPU POM / PA PTFE Bronze	NBR	TPE Resina PTFE Carbo.	PTFE	Sezione Section	Pagina Page
	ISA	-35 +115	-	< 1	POM modificato/ <i>modified</i>	○				Pneumatica Pneumatic	304
	ESA	-35 +115	-	< 1	POM modificato/ <i>modified</i>	○				Pneumatica Pneumatic	306
	NG	-40 +200	-	15	PTFE carbografite			●		Pneumatica Pneumatic	310

RASCHIATORI / WIPERS											
	LWA	-40 +90	-	< 1	TPU	●				Pneumatica Pneumatic	312
	BWA	-40 +90	< 20	< 1	TPU	●				Pneumatica Pneumatic	314
	PIW	-40 +90	< 20	< 1	TPU	●				Pneumatica Pneumatic	316
	BWS	-40 +90	< 20	< 1	TPU	●				Pneumatica Pneumatic	318
	BWH	-40 +90	< 20	< 1	TPU	●				Pneumatica Pneumatic	322
	BWH/N	-30 +100	< 20	< 1	NBR STEEL		●			Pneumatica Pneumatic	324

MEMBRANE SCARICO RAPIDO / QUICK EXHAUST VALVES MEMBRANES											
	CUP	-40 +90	<10	-	TPU	●				Pneumatica Pneumatic	326

Schema cilindro pneumatico A

Pneumatic cylinder sketch A

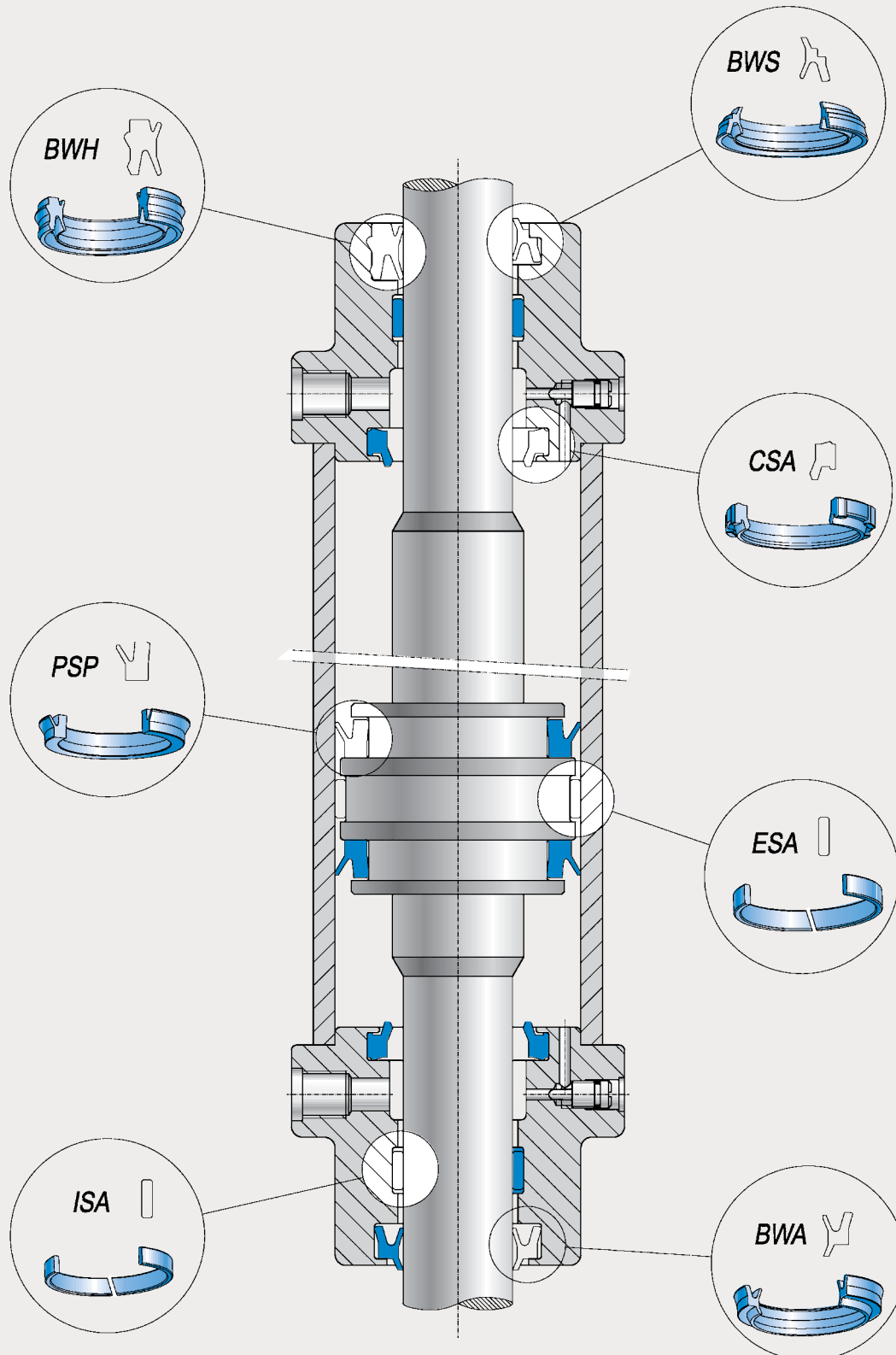



Schema cilindro pneumatico B *Pneumatic cylinder sketch B*

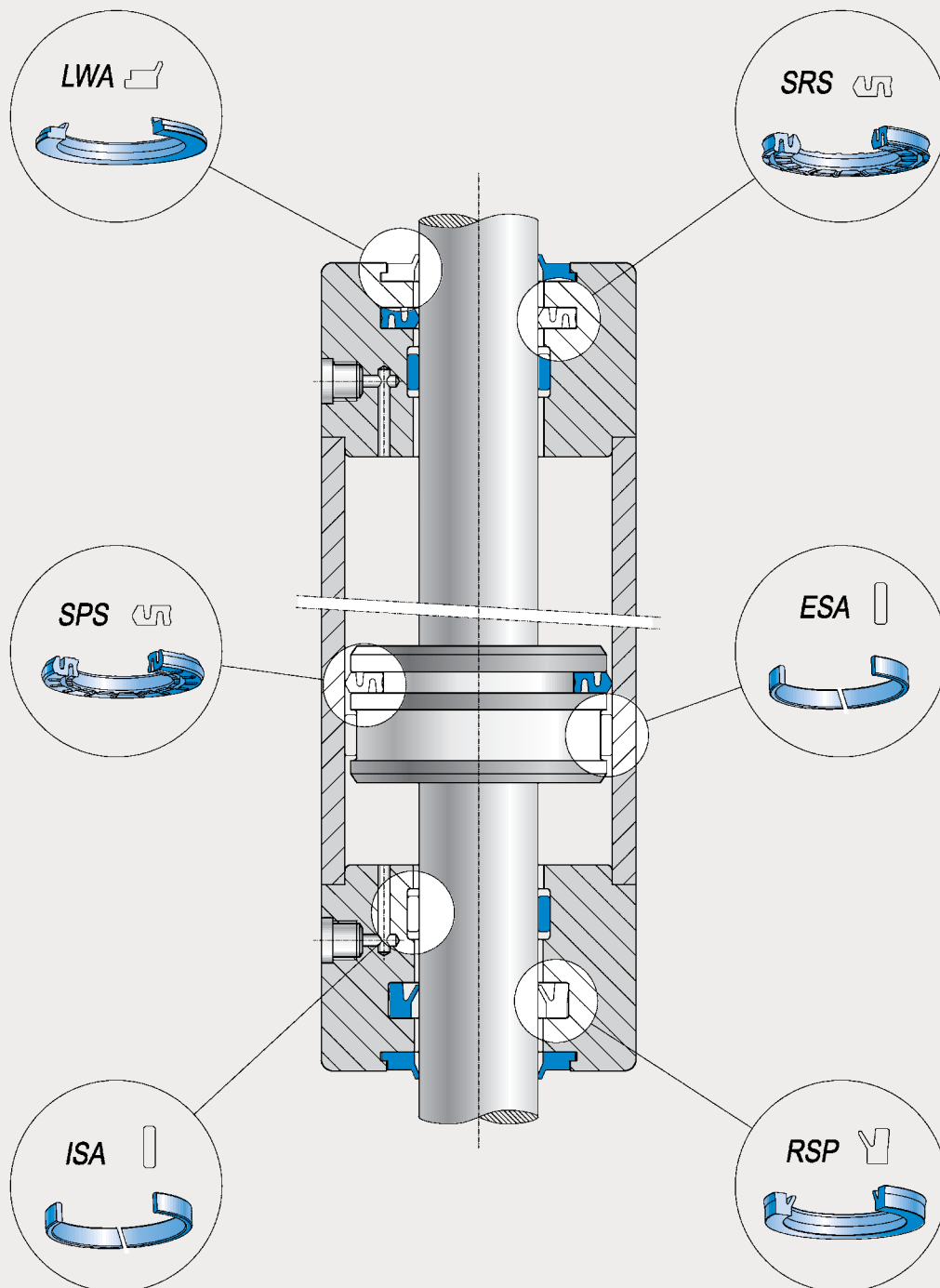

Pneumatica
Pneumatic

Schema cilindro pneumatico C

Pneumatic cylinder sketch C

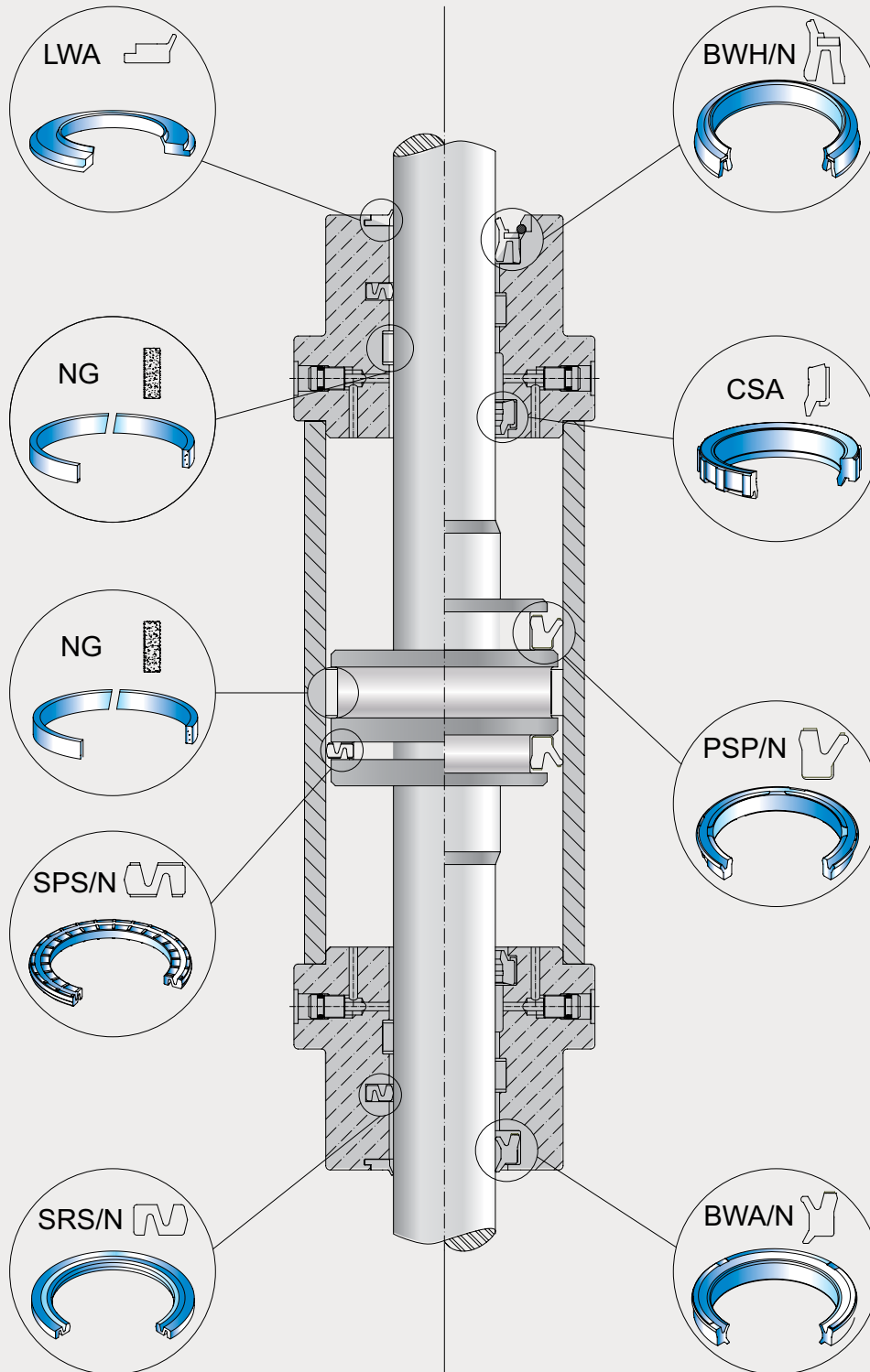



Montaggio Assembling

Avvertenze e precauzioni di montaggio nei sistemi pneumatici

Per un ottimo funzionamento delle guarnizioni occorre evitare tagli e deformazioni permanenti durante il montaggio.

Si raccomanda inoltre di rispettare le norme internazionali ISO per le dimensioni degli alloggiamenti e le tolleranze.

Per le finiture delle superfici e i valori cui attenersi fare riferimento alle figure 37 e 38, mentre per lo smusso d'invito vedere la tabella sotto.

Le finiture di sola rettifica sono sconsigliate e si raccomanda la lucidatura prima del montaggio.

Assembling instructions

For a correct functioning seals it's necessary to avoid cuts or permanent deformations during the assembling process. It's also recommended to follow the ISO norms concerning housings and tolerances. Regarding the surfaces finish, take a look at the following sketches 37 and 38 indicating the values to be respected.

A further polishing operation is usually suggested before mounting, since the only grinding operation isn't recommended.

Fig.37 - Pic.37

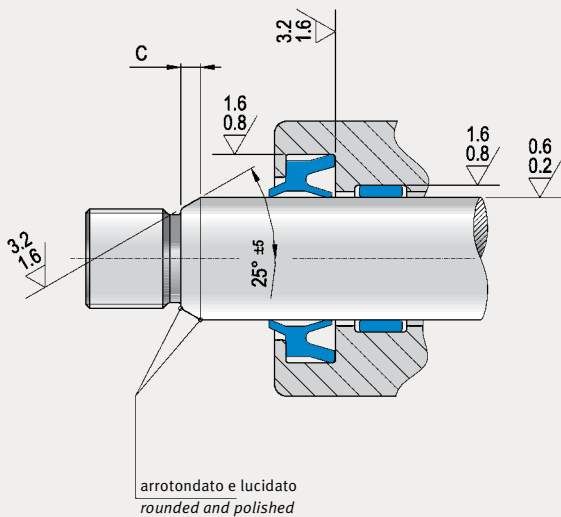
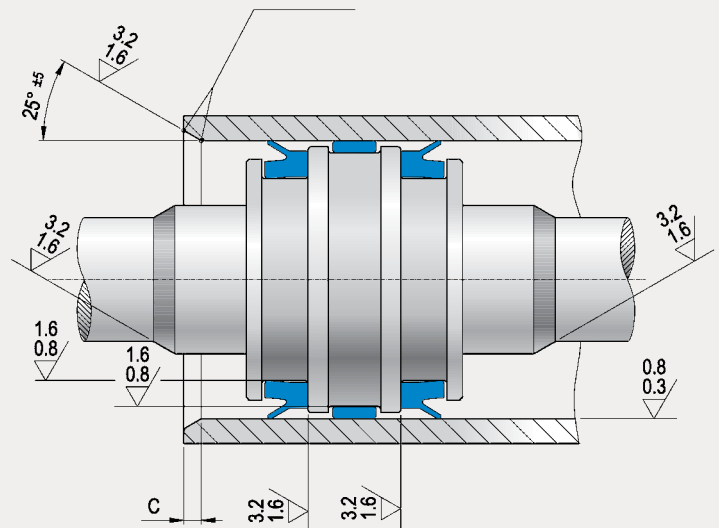
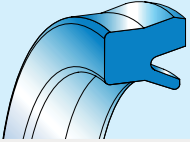

Fig.38 - Pic.38



diametri D-d diameters	< 25	25-60	61-100	101-180	181-300	> 300
C mm	2,5	3,0	4,0	5,0	6,0	7,5



RSP

TENUTA STELO PER PNEUMATICA TIPO RSP

Descrizione

La tenuta stelo tipo RSP è stata progettata per superare i limiti di guarnizioni analoghe e aumentare scorrevolezza e sensibilità alle basse pressioni. Il labbro dinamico arrotondato favorisce la linearità del movimento mentre la marcata profondità della gola tra il labbro dinamico e quello statico aumenta la flessibilità e migliora l'adattamento a eventuali disallineamenti del sistema.

Limiti d'impiego

Pressione: < 20 bar
 Velocità: < 1 m/s
 Temperatura: da - 40° C a + 90° C
 Fluidi: aria con o senza lubrificazione, oli e grassi minerali (v. tabella 3 a p. 14)

Materiale

Materiale standard poliuretano a 90 Shore A.
 Codice materiale: Bo
 Materiale alternativo poliuretano a 85 Shore A.
 Codice materiale alternativo: Ao

Montaggio

Eliminare tutti gli spigoli vivi e le bave nella sede per facilitare il montaggio e non danneggiare la guarnizione durante l'inserimento.
 Lo stelo deve essere privo di bave e avere uno smusso d'invito.

RSP TYPE ROD SEAL FOR PNEUMATIC

Description

The rod seal type RSP, present technical design characteristics aimed to overcome the existing limits of similar seals on the market, in order to obtain a smoother seal which is also more sensible to low pressure.

A rounded dynamic lip improves linear movements. Deeper U-profile between the dynamic and the static lip improves flexibility and performs better in case of misalignments in the system.

Technical data

Pressure: < 20 bar
 Speed: < 1 m/s
 Temperature: from - 40° C up to + 90° C
 Fluids: air with or without lubrication, mineral oils or grease
 (see table 3, page 14)

Material

Standard polyurethane 90 Shore A.
 Compound reference: Bo
 Alternative polyurethane 85 Shore A.
 Alternative compound reference: Ao

Assembling

It is important to remove flashes or cutting edges in the housing to avoid damages.
 The rod must not have present flashes and must have a lead-in chamfer.



RSP

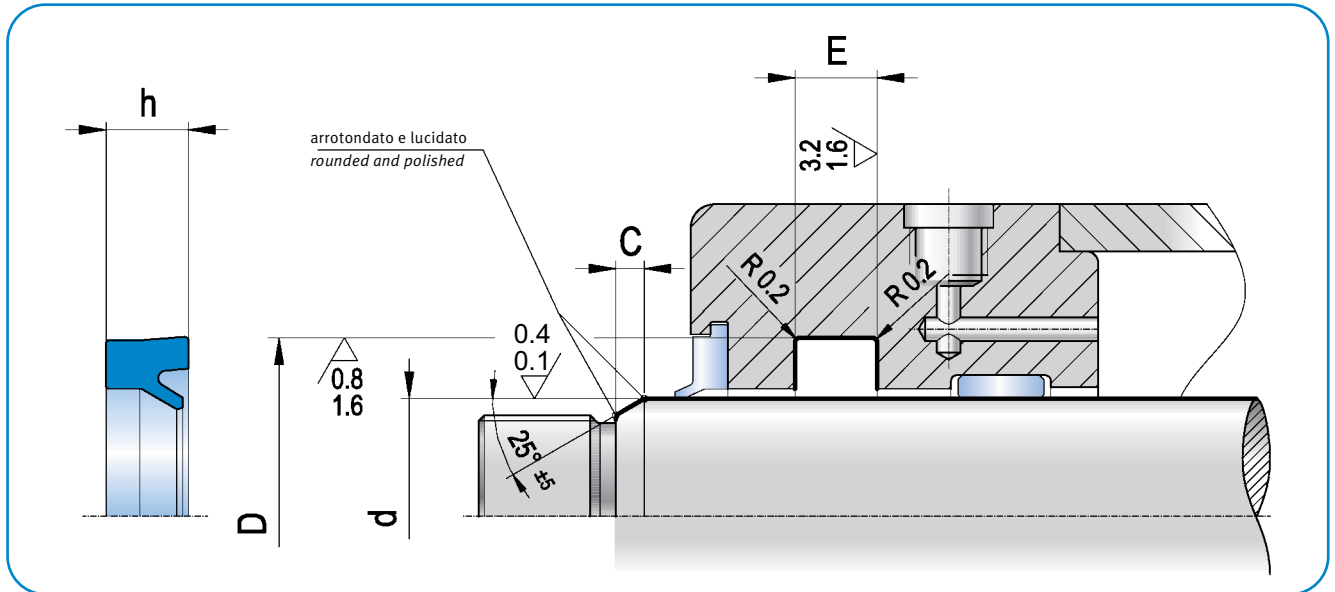
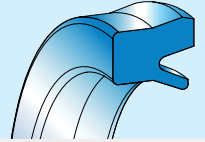

d_{f9}	D_{H10}	toll H_{10}	h	$E_{+0,2}$	ART / ITEM
2,5	6,0	+0.058/0	2,5	3,0	RSP 0025 0060 025 Bo
3,0	6,0	+0.058/0	2,5	3,0	RSP 0030 0060 025 Bo
4,0	8,0	+0.058/0	3,0	3,5	RSP 0040 0080 030 Bo
5,0	9,0	+0.058/0	2,5	3,0	RSP 0050 0090 025 Bo
6,0	10,0	+0.070/0	3,0	3,5	RSP 0060 0100 030 Bo
6,0	11,0	+0.070/0	3,0	3,5	RSP 0060 0110 030 Bo
6,0	12,0	+0.070/0	4,0	4,5	RSP 0060 0120 040 Bo
7,0	13,0	+0.070/0	4,0	4,5	RSP 0070 0130 040 Bo
7,0	14,0	+0.070/0	3,5	4,0	RSP 0070 0140 035 Bo
8,0	14,0	+0.070/0	4,0	4,5	RSP 0080 0140 040 Bo
8,0	14,0	+0.070/0	4,5	5,0	RSP 0080 0140 045 Bo
8,0	16,0	+0.070/0	4,5	5,0	RSP 0080 0160 045 Bo
10,0	14,0	+0.070/0	2,8	3,5	RSP 0100 0140 028 Bo
10,0	16,0	+0.070/0	4,5	5,0	RSP 0100 0160 045 Bo
10,0	18,0	+0.070/0	5,5	6,0	RSP 0100 0180 055 Bo
11,0	19,0	+0.070/0	4,0	4,5	RSP 0110 0190 040 Bo
12,0	20,0	+0.084/0	5,5	6,0	RSP 0120 0200 055 Bo
12,0	24,0	+0.084/0	6,0	6,5	RSP 0120 0240 060 Bo
14,0	22,0	+0.084/0	5,5	6,0	RSP 0140 0220 055 Bo
16,0	22,0	+0.084/0	3,0	3,5	RSP 0160 0220 030 Bo
16,0	24,0	+0.084/0	5,5	6,0	RSP 0160 0240 055 Bo
18,0	22,4	+0.084/0	2,5	3,5	RSP 0180 0224 025 Bo
18,0	26,0	+0.084/0	5,5	6,0	RSP 0180 0260 055 Bo
20,0	28,0	+0.084/0	5,5	6,0	RSP 0200 0280 055 Bo
22,0	28,0	+0.100/0	4,5	5,0	RSP 0220 0280 045 Bo
22,0	30,0	+0.100/0	5,5	6,0	RSP 0220 0300 055 Bo
25,0	33,0	+0.100/0	5,5	6,0	RSP 0250 0330 055 Bo
28,0	36,0	+0.100/0	5,5	6,0	RSP 0280 0360 055 Bo
28,0	38,0	+0.100/0	7,0	7,5	RSP 0280 0380 070 Bo
30,0	38,0	+0.100/0	5,5	6,0	RSP 0300 0380 055 Bo

d_{f9}	D_{H10}	toll H_{10}	h	$E_{+0,2}$	ART / ITEM
30,0	40,0	+0.100/0	6,5	7,0	RSP 0300 0400 065 Bo
30,0	40,0	+0.100/0	7,0	7,5	RSP 0300 0400 070 Bo
30,5	38,5	+0.100/0	7,0	7,5	RSP 0305 0385 070 Bo
32,0	40,0	+0.100/0	5,5	6,0	RSP 0320 0400 055 Bo
32,0	36,4	+0.100/0	2,7	3,5	RSP 0320 0364 027 Bo
35,0	43,0	+0.100/0	8,0	8,5	RSP 0350 0430 080 Bo
35,0	45,0	+0.100/0	7,0	7,5	RSP 0350 0450 070 Bo
35,0	45,0	+0.100/0	10,0	10,5	RSP 0350 0450 100 Bo
36,0	46,0	+0.100/0	7,0	7,5	RSP 0360 0460 070 Bo
40,0	48,0	+0.100/0	5,5	6,0	RSP 0400 0480 055 Bo
40,0	50,0	+0.100/0	7,0	7,5	RSP 0400 0500 070 Bo
44,5	52,5	+0.120/0	7,0	7,5	RSP 0445 0525 070 Bo
45,0	55,0	+0.120/0	7,0	7,5	RSP 0450 0550 070 Bo
50,0	56,0	+0.120/0	5,0	5,5	RSP 0500 0560 050 Bo
50,0	60,0	+0.120/0	7,0	7,5	RSP 0500 0600 070 Bo
55,0	65,0	+0.120/0	7,0	7,5	RSP 0550 0650 070 Bo
56,0	66,0	+0.120/0	7,0	7,5	RSP 0560 0660 070 Bo
60,0	72,0	+0.120/0	8,5	9,5	RSP 0600 0720 085 Bo
62,0	72,0	+0.120/0	7,0	7,5	RSP 0620 0720 070 Bo
63,0	73,0	+0.120/0	7,0	7,5	RSP 0630 0730 070 Bo
63,0	75,0	+0.120/0	8,5	9,5	RSP 0630 0750 085 Bo
65,0	77,0	+0.120/0	8,5	9,5	RSP 0650 0770 085 Bo
70,0	82,0	+0.120/0	8,5	9,5	RSP 0700 0820 085 Bo
75,0	87,0	+0.120/0	8,5	9,5	RSP 0750 0870 085 Bo
80,0	92,0	+0.120/0	8,5	9,5	RSP 0800 0920 085 Bo
85,0	97,0	+0.120/0	8,5	9,5	RSP 0850 0970 085 Bo
90,0	102,0	+0.120/0	8,5	9,5	RSP 0900 1020 085 Bo
95,0	107,0	+0.120/0	8,5	9,5	RSP 0950 1070 085 Bo
100,0	115,0	+0.120/0	10,0	11,0	RSP 1000 1150 100 Bo

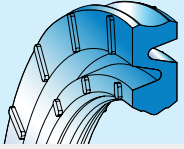

SRS

TENUTA STELO A MOLLA TIPO SRS

Descrizione

La guarnizione tipo SRS è progettata per la tenuta stelo di cilindri pneumatici e per valvole pneumatiche dove gli ingombri lo permettono. Presenta un profilo arrotondato al centro sul labbro dinamico e due sporgenze sul labbro statico. Le ridotte dimensioni delle sedi consentono un'esecuzione di lavorazione macchina semplice. La particolare forma a molla rende il sistema molto scorrevole anche a bassa pressione mentre il profilo simmetrico ne facilita il montaggio.

Limiti d'impiego

Pressione: < 20 bar
 Velocità: < 1 m/s
 Temperatura: da - 40° C a + 90° C
 Fluidi: aria con o senza lubrificazione, oli e grassi minerali (v. tabella 3 a p. 14)

Materiale

Materiale standard poliuretano a 90 Shore A.
 Codice materiale standard: Bo
 Materiale alternativo poliuretano a 85 Shore A.
 Codice materiale alternativo: Ao

Montaggio

Eliminare tutti gli spigoli vivi e le bave per evitare di compromettere la guarnizione.
 Lo stelo deve essere privo di bave e avere uno smusso d'invito.

SRS TYPE SPRING ROD SEAL

Description

The SRS rod seal has been designed for pneumatic cylinder applications. The SRS can also be used for pneumatic valves where the overall dimensions allowed. Moreover a shorter machining of the system can be obtained thanks to the reduced overall dimensions. The profile is rounded in the middle of the dynamic lip and it has two projections on the static lip. This symmetrical shape allows easier installation. The special spring shaped profile ensures high flexibility in the system even at low pressure.

Technical data

Pressure: < 20 bar
 Speed: < 1 m/s
 Temperature: from - 40° C up to + 90° C
 Fluids: air with or without lubrication, mineral oils or grease
 (see table 3, page 14)

Material

Standard polyurethane 90 Shore A.
 Standard compound reference: Bo
 Alternative polyurethane 85 Shore A.
 Alternative compound reference: Ao

Assembling

*It is important to remove flashes or cutting edges in the housing to avoid damages.
 The rod must not have present flashes and must have a lead-in chamfer.*



SRS

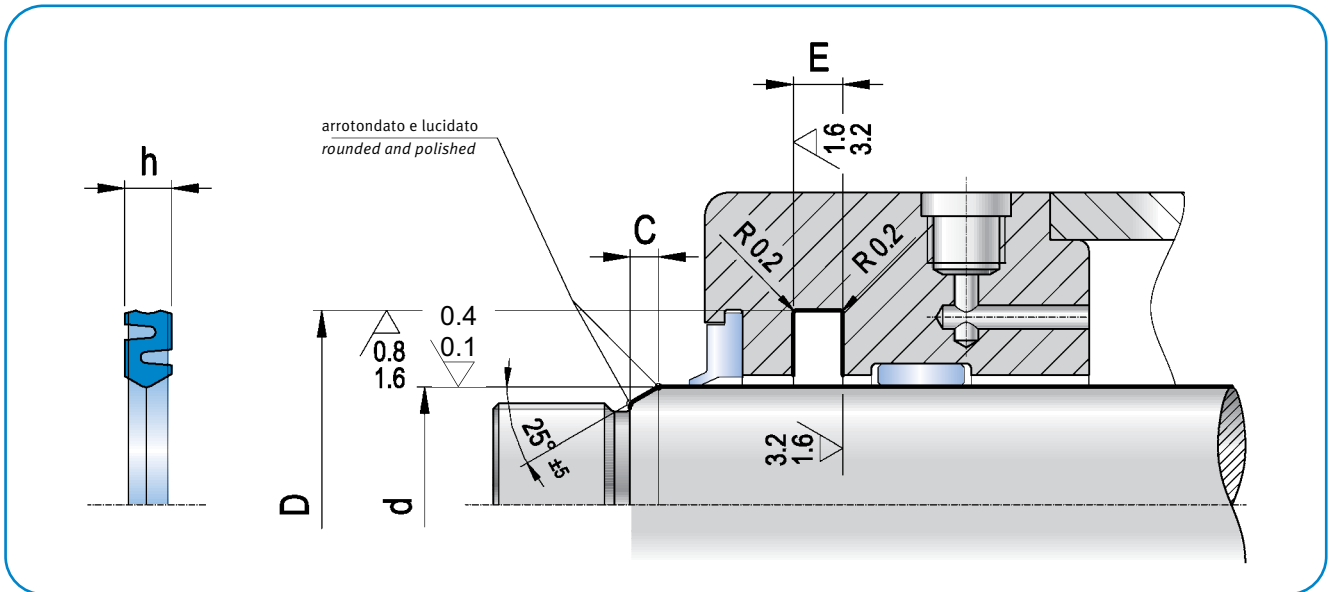
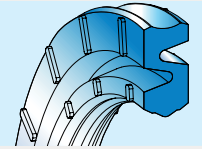

d_f	D_{H10}	toll H10	h	$E_{+0,2}$	ART / ITEM
6,0	13,0	+0,043/0	2,3	2,5	SRS 0060 0130 023 Bo
8,0	15,0	+0,043/0	2,3	2,5	SRS 0080 0150 023 Bo
10,0	17,0	+0,043/0	2,3	2,5	SRS 0100 0170 023 Bo
12,0	19,0	+0,052/0	2,3	2,5	SRS 0120 0190 023 Bo
14,0	21,0	+0,052/0	2,3	2,5	SRS 0140 0210 023 Bo
15,0	22,0	+0,052/0	2,3	2,5	SRS 0150 0220 023 Bo
16,0	25,0	+0,052/0	2,8	3,0	SRS 0160 0250 028 Bo
20,0	29,0	+0,052/0	2,8	3,0	SRS 0200 0290 028 Bo
25,0	34,0	+0,062/0	2,8	3,0	SRS 0250 0340 028 Bo
30,0	39,0	+0,062/0	2,8	3,0	SRS 0300 0390 028 Bo
40,0	49,0	+0,062/0	2,8	3,0	SRS 0400 0490 028 Bo
42,0	51,0	+0,074/0	2,8	3,0	SRS 0420 0510 028 Bo
50,0	59,0	+0,074/0	2,8	3,0	SRS 0500 0590 028 Bo

Nota: altre dimensioni non a catalogo a richiesta. Consultare il nostro ufficio tecnico.

Remark: please contact our technical dept. for further dimensions not included in the catalogue.

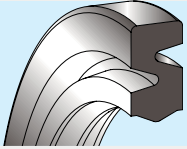

SRS/N

TENUTA STELO A MOLLA TIPO SRS/N

Descrizione

La guarnizione tipo SRS/N è realizzata per tenuta stelo di cilindri pneumatici e per valvole pneumatiche dove gli ingombri lo permettono. Le ridotte dimensioni delle sedi consentono un'esecuzione di lavorazione macchina veloce e semplice. Il profilo simmetrico ne facilita il montaggio mentre la particolare forma a molla rende il sistema molto scorrevole anche a bassissima pressione.

Limiti d'impiego

Pressione: < 12 [bar]
 Velocità: < 1 [m/s]
 Temperatura: -30 °C ÷ +100 °C mescola NBR
 -15 °C ÷ +150 °C mescola FKM
 Fluidi: aria lubrificata, grassi e oli minerali (v. tabella 3 a p. 14)

Materiale

Il materiale standard è NBR 80 Shore A.
 A richiesta materiale FKM 75 Shore A.
 Codice materiale standard: N1

Montaggio

Eliminare spigoli vivi e bave per non danneggiare la tenuta al momento del montaggio.
 Lo stelo deve essere privo di bave e avere uno smusso d'invito.

SRS/N TYPE SPRING ROD SEAL

Description

The seal type SRS / N is a rod seal for pneumatic cylinders.
 The SRS/N can also be used for pneumatic valves where the overall dimensions allowed.
 The reduced dimensions of the seat allows fast and simple machining operations.
 This symmetrical profile allows easier installation.
 The special spring shape ensure a system sliding even at very low pressure.

Technical data

Pressure: < 12 [bar]
 Speed: < 1 [m/s]
 Temperature: -30 °C ÷ +100 °C NBR material
 -15 °C ÷ +150 °C FKM material
 Fluids: Lubricated air, grease and mineral oils (see table 3, page 14)

Material

Standard material is NBR 80 Shore A.
 On demand material FKM 75 Shore A
 Standard compound reference: N1

Assembling

It is important to remove flashes or cutting edges in the housing to avoid damages.
 The rod must not have present flashes and must have a lead-in chamfer.



SRS / N

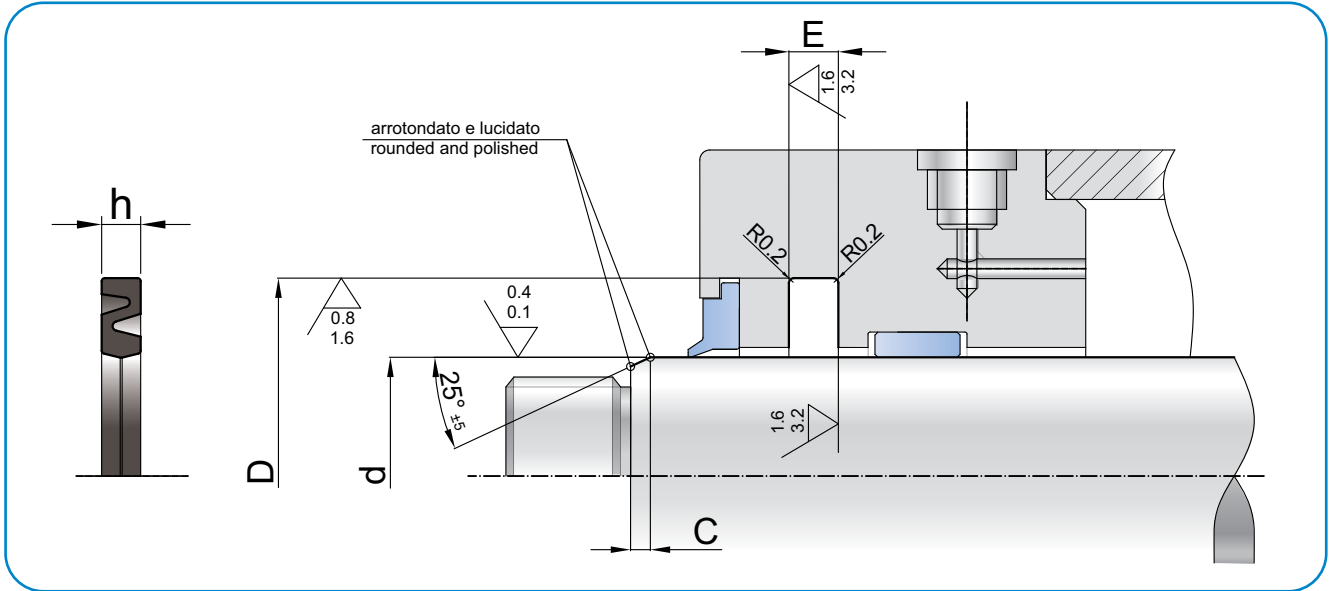
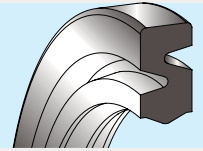

d_{f9}	D_{H10}	Toll h_{10}	h	$E_{+0,2}$	ART / ITEM
6,0	13,0	0/-0,043	2,30	2,50	SRS 0060 0130 023 N1
8,0	15,0	0/-0,043	2,30	2,50	SRS 0080 0150 023 N1
10,0	17,0	0/-0,043	2,30	2,50	SRS 0100 0170 023 N1
12,0	19,0	0/-0,052	2,30	2,50	SRS 0120 0190 023 N1
14,0	21,0	0/-0,052	2,30	2,50	SRS 0140 0210 023 N1
15,0	22,0	0/-0,052	2,30	2,50	SRS 0150 0220 023 N1
16,0	25,0	0/-0,052	2,80	3,00	SRS 0160 0250 028 N1
20,0	29,0	0/-0,052	2,80	3,00	SRS 0200 0290 028 N1
25,0	34,0	0/-0,062	2,80	3,00	SRS 0250 0340 028 N1
30,0	39,0	0/-0,062	2,80	3,00	SRS 0300 0390 028 N1
40,0	49,0	0/-0,062	2,80	3,00	SRS 0400 0490 028 N1
42,0	51,0	0/-0,074	2,80	3,00	SRS 0420 0510 028 N1
50,0	59,0	0/-0,074	2,80	3,00	SRS 0500 0590 028 N1

Nota: altre dimensioni non a catalogo a richiesta. Consultare il nostro ufficio tecnico.

Remark: please contact our technical dept. for further dimensions not included in the catalogue.

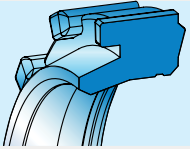

CSA

GUARNIZIONI AMMORTIZZO TIPO CSA

Descrizione

L'elemento d'ammortizzo tipo CSA è studiato per la frenatura di fine corsa nei pistoni dei cilindri pneumatici.

Queste le caratteristiche che concorrono all'efficacia del sistema frenante della guarnizione CSA:

- il profilo raschiante con lo smusso d'invito che facilita l'inserimento dell'ogiva
- le scanalature all'esterno che permettono l'allineamento
- il bordo alla base dell'ammortizzo
- l'utilizzo del poliuretano che grazie all'alto modulo elastico e all'alta resistenza all'urto garantisce una lunga durata in esercizio.

Limiti d'impiego

Pressione: < 20 bar

Velocità: < 1 m/s

Temperatura: da - 40° C a + 90° C

Fluidi: aria con o senza lubrificazione, oli e grassi minerali (v. tabella 3 a p. 14)

Materiale

Il materiale standard è un poliuretano a basso compression-set con una buona flessibilità a freddo.

Materiale standard poliuretano a 90 Shore A.

Codice materiale standard: Bo

Materiale alternativo, (d > 40) poliuretano a 93 Shore A.

Codice materiale alternativo: Co

Montaggio

Il montaggio avviene in sede semiaperta, pertanto si consiglia di eliminare tutti gli spigoli vivi e le bave per evitare di compromettere la guarnizione.

Lubrificare con grasso per prolungare la durata.

CSA TYPE CUSHIONING SEAL

Description

The CSA cushioning seal is designed for braking points at the end-stroke of pneumatic cylinders.

Several elements contribute to the increased efficiency of the CSA seal braking system:

- the scraping profile with lead-in chamfer for better insertion of the shoulder
- the external grooves granting auto-alignment
- the edge at the bottom of the cushioning
- the use of polyurethane which ensures a long service life thanks to the high modulus of elasticity
- and the very good impact resistance.

Technical data

Pressure: < 20 bar

Speed: < 1 m/s

Temperature: from - 40° C up to + 90° C

Fluids: air with or without lubrication, mineral oils or grease
(see table 3, page 14)

Material

The standard raw material is a low compression-set polyurethane with good flexibility at low temperature.

Standard polyurethane 90 Shore A.

Standard compound reference: Bo

Alternative (d > 40) polyurethane 93 Shore A.

Alternative compound reference: Co

Assembling

The assembling is done in semi-open groove, therefore cutting edges or flashes should be removed otherwise they may influence the sealing performance.

Lubrication with grease will increase lifetime of the seal.



CSA

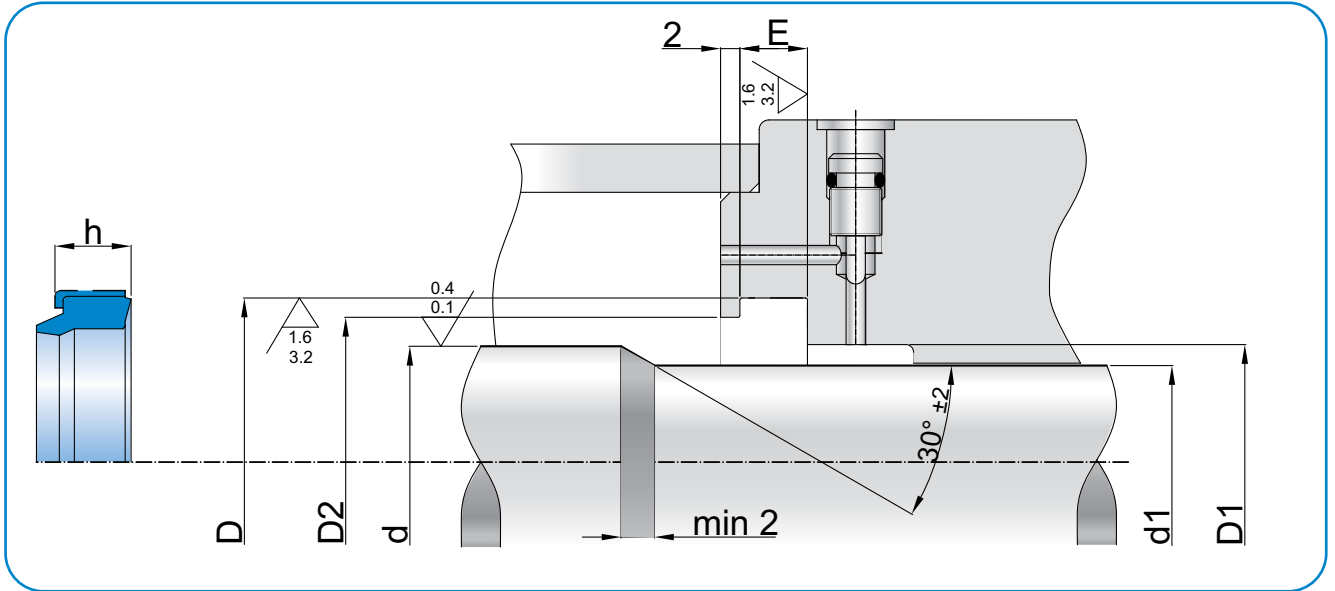
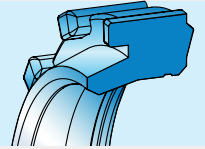

d_{h10}	$toll_{h10}$	D_{H11}	D_1	D_2	d_1	h	E	ART / ITEM
6,0	0/-0.048	10,0	6,5	8,0	4,5	3,4	3,7	CSA 0060 0100 034 Bo
8,0	0/-0.058	11,6	8,5	10,0	7,0	3,0	3,3	CSA 0080 0116 030 Bo
9,5	0/-0.058	15,0	10,0	12,0	8,0	4,0	4,5	CSA 0095 0150 040 Bo
10,0	0/-0.058	18,0	11,0	15,0	8,0	6,5	7,0	CSA 0100 0180 065 Bo
12,0	0/-0.070	18,0	13,0	15,5	10,0	4,3	4,8	CSA 0120 0180 043 Bo
12,0	0/-0.070	20,0	13,0	17,0	10,0	6,5	7,0	CSA 0120 0200 065 Bo
14,0	0/-0.070	22,0	15,0	19,0	12,0	6,5	7,0	CSA 0140 0220 065 Bo
16,0	0/-0.070	22,0	17,0	19,5	14,0	4,7	5,2	CSA 0160 0220 047 Bo
16,0	0/-0.070	24,0	17,0	21,0	14,0	6,5	7,0	CSA 0160 0240 065 Bo
18,0	0/-0.070	26,0	19,0	23,0	16,0	6,5	7,0	CSA 0180 0260 065 Bo
20,0	0/-0.084	28,0	21,0	24,0	17,5	6,5	7,0	CSA 0200 0280 065 Bo
22,0	0/-0.084	30,0	23,0	26,0	19,5	6,5	7,0	CSA 0220 0300 065 Bo
25,0	0/-0.084	33,0	26,0	29,0	22,5	6,5	7,0	CSA 0250 0330 065 Bo
28,0	0/-0.084	36,0	29,0	32,0	25,5	6,5	7,0	CSA 0280 0360 065 Bo
30,0	0/-0.084	40,0	31,5	35,0	27,5	6,5	7,0	CSA 0300 0400 065 Bo
32,0	0/-0.084	42,0	33,5	37,0	29,0	6,5	7,0	CSA 0320 0420 065 Bo
36,0	0/-0.100	46,0	37,5	41,0	33,0	6,5	7,0	CSA 0360 0460 065 Bo
40,0	0/-0.100	50,0	41,5	45,0	37,0	6,5	7,0	CSA 0400 0500 065 Bo
50,0	0/-0.100	60,0	51,5	55,0	47,0	6,5	7,0	CSA 0500 0600 065 Bo
57,0	0/-0.120	74,0	60,0	65,0	54,0	12,0	12,5	CSA 0570 0740 120 Bo
70,0	0/-0.120	87,0	73,0	78,0	66,0	12,0	12,5	CSA 0700 0870 120 Bo
78,0	0/-0.120	95,0	81,0	86,0	74,0	12,0	12,5	CSA 0780 0950 120 Bo

Nota: altre dimensioni non a catalogo a richiesta. Consultare il nostro ufficio tecnico.

Remark: please contact our technical dept. for further dimensions not included in the catalogue.

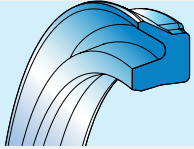

PSP

TENUTA PISTONE PER PNEUMATICA TIPO PSP

Descrizione

La guarnizione tipo PSP è progettata per la tenuta pistone di cilindri pneumatici a semplice e doppio effetto.

La gola molto marcata tra il labbro dinamico e quello statico e la raggiatura dei due labbri di contatto aumentano la scorrevolezza della guarnizione, anche in assenza di lubrificazione.

Le limitate dimensioni e l'alta flessibilità del materiale semplificano il montaggio anche in cava chiusa.

Limiti d'impiego

Pressione: < 20 bar

Velocità: < 1 m/s

Temperatura: da - 40° C a + 90° C

Fluidi: aria con o senza lubrificazione, oli e grassi minerali (v. tabella 3 a p.14)

Materiale

Materiale standard poliuretano a 90 Shore A.

Codice materiale standard: Bo

Materiale alternativo poliuretano a 85 Shore A.

Codice materiale alternativo: Ao

Montaggio

Eliminare tutti gli spigoli vivi e le bave nella sede del pistone per evitare di compromettere la guarnizione.

Eseguire uno smusso sulla camicia del cilindro per facilitare il montaggio.

Si consiglia di lubrificare la guarnizione per rendere il sistema molto scorrevole.

PSP TYPE PISTON SEAL FOR PNEUMATICS

Description

The PSP piston seal has been designed for single and double action pneumatic cylinders.

The deep groove between the dynamic and the static lip, together with back-to-back radius lips, enhance seal sliding, even where there is a lack of environmental lubrication.

The reduced dimensions, together with the high flexibility of the material, also facilitates installation in closed grooves.

Technical data

Pressure: < 20 bar

Speed: < 1 m/s

Temperature: from - 40° C up to + 90° C

Fluids: air with or without lubrication, mineral oils or grease
(see table 3, page 14)

Material

Standard polyurethane 90 Shore A.

Standard compound reference: Bo

Alternative polyurethane 85 Shore A.

Alternative compound reference: Ao

Assembling

It is important to remove flashes or cutting edges in the housing to avoid damages.

The bore must not have flashes and must present a lead-in chamfer.

Lubrication with grease will increase lifetime of the seal.



PSP

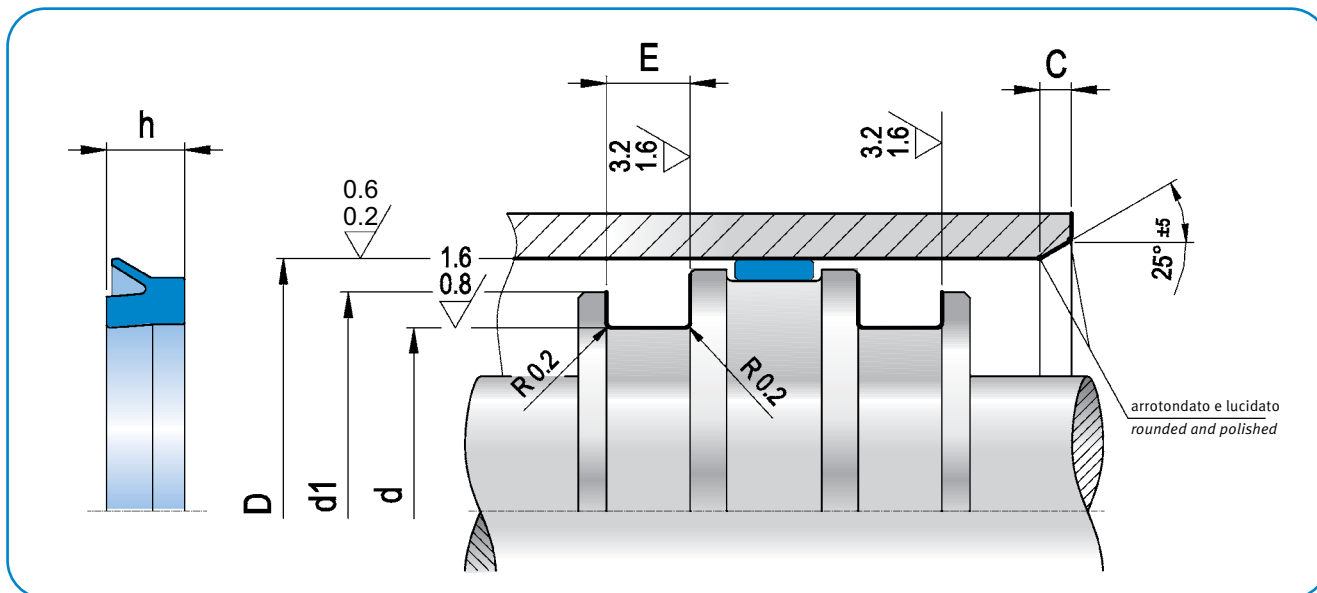
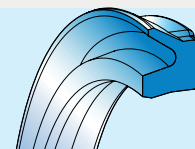

D _{H11}	d _{h10}	Toll. H10	d1*	h	E _{+0,2}	ART / ITEM
6,0	3,0	0/-0.048	5,0	2,00	2,50	PSP 0060 0030 020 Bo
8,0	4,0	0/-0.048	7,0	2,55	3,00	PSP 0080 0040 025 Bo
8,0	4,8	0/-0.048	7,0	2,30	2,70	PSP 0080 0048 023 Bo
8,0	4,8	0/-0.048	7,0	2,55	3,00	PSP 0080 0048 025 Bo
8,2	5,1	0/-0.048	7,5	2,30	2,70	PSP 0082 0051 023 Bo
10,0	6,0	0/-0.048	9,0	2,55	3,00	PSP 0100 0060 025 Bo
12,0	7,0	0/-0.058	11,0	2,55	3,00	PSP 0120 0070 025 Bo
12,0	9,0	0/-0.058	11,0	2,10	2,50	PSP 0120 0090 021 Bo
12,7	8,0	0/-0.058	12,0	3,25	3,50	PSP 0127 0080 032 Bo
13,0	8,0	0/-0.058	12,0	2,55	3,00	PSP 0130 0080 025 Bo
14,0	8,0	0/-0.058	13,0	2,55	3,00	PSP 0140 0080 025 Bo
15,0	9,0	0/-0.058	14,0	2,55	3,00	PSP 0150 0090 025 Bo
16,0	10,0	0/-0.058	15,0	2,55	3,00	PSP 0160 0100 025 Bo
17,0	11,0	0/-0.070	16,0	2,55	3,00	PSP 0170 0110 025 Bo
18,0	12,0	0/-0.070	17,0	2,55	3,00	PSP 0180 0120 025 Bo
20,0	14,0	0/-0.070	19,0	2,55	3,00	PSP 0200 0140 025 Bo
20,0	14,0	0/-0.070	19,0	4,00	4,50	PSP 0200 0140 040 Bo
20,0	15,5	0/-0.070	19,0	4,00	4,50	PSP 0200 0155 040 Bo
22,0	16,0	0/-0.070	21,0	2,55	3,00	PSP 0220 0160 025 Bo
24,0	12,0	0/-0.070	23,0	6,50	7,50	PSP 0240 0120 065 Bo
24,0	18,0	0/-0.070	23,0	2,55	3,00	PSP 0240 0180 025 Bo
25,0	17,0	0/-0.070	24,0	5,50	6,00	PSP 0250 0170 055 Bo
25,0	19,0	0/-0.084	24,0	3,25	3,50	PSP 0250 0190 032 Bo
25,0	19,0	0/-0.084	24,0	4,00	4,50	PSP 0250 0190 040 Bo
27,0	21,0	0/-0.084	26,0	3,25	4,00	PSP 0270 0210 032 Bo
28,0	18,0	0/-0.084	27,0	7,00	7,50	PSP 0280 0180 070 Bo
28,0	22,0	0/-0.084	27,0	3,25	3,50	PSP 0280 0220 032 Bo

* diametro di aggancio consigliato ma modificabile in funzione delle esigenze di montaggio

* recommended hook diameter which could be modified according to mounting demand

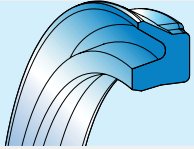

PSP

D _{H11}	d _{h10}	Toll. H10	d1*	h	E _{+0,2}	ART / ITEM				
30,0	20,0	0/-0.084	29,0	5,00	6,00	PSP	0300	0200	050	BO
30,0	22,0	0/-0.084	29,0	3,25	3,50	PSP	0300	0220	032	Bo
30,0	22,0	0/-0.084	29,0	5,50	6,00	PSP	0300	0220	055	Bo
32,0	24,0	0/-0.084	31,0	3,25	3,50	PSP	0320	0240	032	Bo
32,0	24,0	0/-0.084	31,0	5,50	6,00	PSP	0320	0240	055	Bo
35,0	27,0	0/-0.084	34,0	3,25	3,50	PSP	0350	0270	032	Bo
36,0	28,0	0/-0.084	35,0	3,25	3,50	PSP	0360	0280	032	Bo
38,0	30,0	0/-0.084	37,0	3,25	3,50	PSP	0380	0300	032	Bo
38,0	30,0	0/-0.084	37,0	5,50	6,00	PSP	0380	0300	055	Bo
40,0	27,3	0/-0.084	39,0	6,40	7,50	PSP	0400	0273	064	BO
40,0	30,0	0/-0.084	39,0	7,00	7,50	PSP	0400	0300	070	Bo
40,0	32,0	0/-0.100	39,0	3,25	3,50	PSP	0400	0320	032	Bo
42,0	30,0	0/-0.100	41,0	6,00	6,50	PSP	0420	0300	060	Bo
42,0	34,0	0/-0.100	41,0	3,25	3,50	PSP	0420	0340	032	Bo
45,0	35,0	0/-0.100	44,0	10,00	11,00	PSP	0450	0350	100	BO
45,0	37,0	0/-0.100	44,0	3,25	3,50	PSP	0450	0370	032	Bo
50,0	40,0	0/-0.100	49,0	5,00	6,00	PSP	0500	0400	050	BO
50,0	40,0	0/-0.100	49,0	7,00	7,50	PSP	0500	0400	070	Bo
50,0	42,0	0/-0.100	49,0	3,25	3,50	PSP	0500	0420	032	Bo
52,0	42,0	0/-0.100	51,0	4,25	4,50	PSP	0520	0420	042	Bo
55,0	45,0	0/-0.100	54,0	7,00	7,50	PSP	0550	0450	070	Bo
58,0	48,0	0/-0.100	57,0	4,25	4,50	PSP	0580	0480	042	Bo
60,0	50,0	0/-0.120	59,0	5,00	5,70	PSP	0600	0500	050	Bo
60,0	50,0	0/-0.120	59,0	7,00	7,50	PSP	0600	0500	070	Bo
63,0	53,0	0/-0.120	62,0	4,25	4,50	PSP	0630	0530	042	Bo
63,0	53,0	0/-0.120	62,0	7,00	7,50	PSP	0630	0530	070	Bo
65,0	55,0	0/-0.120	64,0	5,00	6,00	PSP	0650	0550	050	BO
65,0	55,0	0/-0.120	64,0	7,00	7,50	PSP	0650	0550	070	Bo
68,0	58,0	0/-0.120	67,0	4,70	5,50	PSP	0680	0580	047	Bo
70,0	54,1	0/-0.120	69,0	8,00	9,00	PSP	0700	0541	080	Bo
70,0	58,0	0/-0.120	69,0	8,50	9,50	PSP	0700	0580	085	Bo
75,0	63,0	0/-0.120	74,0	8,50	9,50	PSP	0750	0630	085	Bo
80,0	67,3	0/-0.120	79,0	6,35	7,00	PSP	0800	0673	063	Bo
80,0	68,0	0/-0.120	79,0	8,50	9,50	PSP	0800	0680	085	Bo
80,0	70,0	0/-0.120	79,0	4,25	4,50	PSP	0800	0700	042	Bo
85,0	71,5	0/-0.120	84,0	9,20	10,00	PSP	0850	0715	092	Bo
85,0	73,0	0/-0.120	84,0	8,50	9,50	PSP	0850	0730	085	Bo
86,0	73,3	0/-0.120	85,0	9,00	10,00	PSP	0860	0733	090	Bo
90,0	78,0	0/-0.120	89,0	8,50	9,50	PSP	0900	0780	085	Bo
90,0	80,0	0/-0.120	89,0	4,25	4,50	PSP	0900	0800	042	Bo
100,0	88,0	0/-0.140	99,0	8,50	9,50	PSP	1000	0880	085	Bo
100,0	90,0	0/-0.140	99,0	4,25	4,50	PSP	1000	0900	042	Bo



PSP

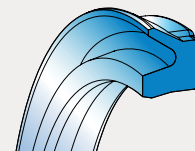

D _{H11}	d _{h10}	Toll. H10	d1*	h	E _{+0,2}	ART / ITEM				
110,0	95,0	0/-0.140	109,0	10,00	11,00	PSP	1100	0950	100	Bo
120,0	105,0	0/-0.140	119,0	10,00	11,00	PSP	1200	1050	100	Bo
125,0	105,0	0/-0.140	124,0	8,25	8,50	PSP	1250	1050	082	Bo
125,0	110,0	0/-0.140	124,0	10,00	11,00	PSP	1250	1100	100	Bo
140,0	120,0	0/-0.140	139,0	8,25	8,50	PSP	1400	1200	082	Bo
152,0	145,0	0/-0.140	151,0	3,70	4,00	PSP	1520	1450	037	Bo
160,0	140,0	0/-0.160	159,0	8,25	8,50	PSP	1600	1400	082	Bo
160,0	145,0	0/-0.160	159,0	10,00	11,00	PSP	1600	1450	100	Bo
180,0	160,0	0/-0.160	179,0	14,00	15,00	PSP	1800	1600	140	Bo
185,0	171,0	0/-0.160	184,0	7,00	7,50	PSP	1850	1710	070	Bo
190,0	170,0	0/-0.160	189,0	15,00	16,00	PSP	1900	1700	150	Bo
200,0	180,0	0/-0.160	199,0	8,25	8,50	PSP	2000	1800	082	Bo
200,0	180,0	0/-0.160	199,0	12,00	13,00	PSP	2000	1800	120	Bo
200,0	180,0	0/-0.160	199,0	14,00	15,00	PSP	2000	1800	140	Bo
250,0	230,0	0/-0.185	249,0	14,00	15,00	PSP	2500	2300	140	Bo

* diametro di aggancio consigliato ma modificabile in funzione delle esigenze di montaggio

* recommended hook diameter which could be modified according to mounting demand

Nota: altre dimensioni non a catalogo a richiesta. Consultare il nostro ufficio tecnico.

Remark: please contact our technical dept. for further dimensions not included in the catalogue.

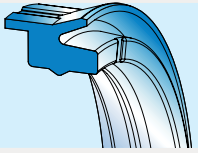

MPS

TENUTA PISTONE MAGNETICO TIPO MPS

Descrizione

La guarnizione tipo MPS è stata studiata sia per pistoni di cilindri pneumatici compatti a corsa breve sia per il semplice e doppio effetto. L'elemento di guida è sulla guarnizione stessa. Appositi interstizi e notches creano spazi per trattenere il grasso lubrificante mantenendo elevata la scorrevolezza del pistone nel tempo. Il magnete è alloggiato all'interno tra le due guarnizioni contrapposte. Specifiche progettuali personalizzate sono a disposizione per soluzioni alternative.

Limiti d'impiego

Pressione: < 20 bar
 Velocità: < 1 m/s
 Temperatura: da -40° C a +90° C
 Fluidi: aria con o senza lubrificazione, oli e grassi minerali (v. tabella 3 a p. 14)

Materiale

Materiale standard poliuretano a 90 Shore A.
 Codice materiale standard: Bo
 Materiale alternativo poliuretano a 85 Shore A.
 Codice materiale alternativo: Ao

Montaggio

Eliminare tutti gli spigoli vivi e le bave nella sede del pistone per evitare di compromettere la guarnizione. Il montaggio si effettua per accavallamento della guarnizione sul diametro del pistone, che deve essere sagomato esattamente come da disegno della tabella dimensionale MPS. Eseguire uno smusso sulla camicia del cilindro.

MPS TYPE MAGNETIC PISTON SEAL

Description

The MPS seal has been specifically designed either for pneumatic compact short stroke cylinders and single/double effect cylinders. The guiding element is integrated on the seal. Specific notches keep the lubricant grease maintaining a sliding effect on the piston for long time. The magnet is located between the two opposed gaskets. For specific needs or problems, our technical office is at your complete disposal with tailor-made solutions.

Technical data

Pressure: < 20 bar
 Speed: < 1 m/s
 Temperature: from -40° C up to +90° C
 Fluids: air with or without lubrication, mineral oils or grease
 (see table 3, page 14)

Material

Standard polyurethane 90 Shore A.
 Standard compound reference: Bo
 Alternative polyurethane 85 Shore A.
 Alternative compound reference: Ao

Assembling

It is important to remove flashes or cutting edges in the housing to avoid damages. The installation is made by overlapping the seal on the piston diameter. Warning: the piston must be correctly shaped according to the drawing of the MPS dimensions table. The bore must present a lead-in chamfer.



MPS

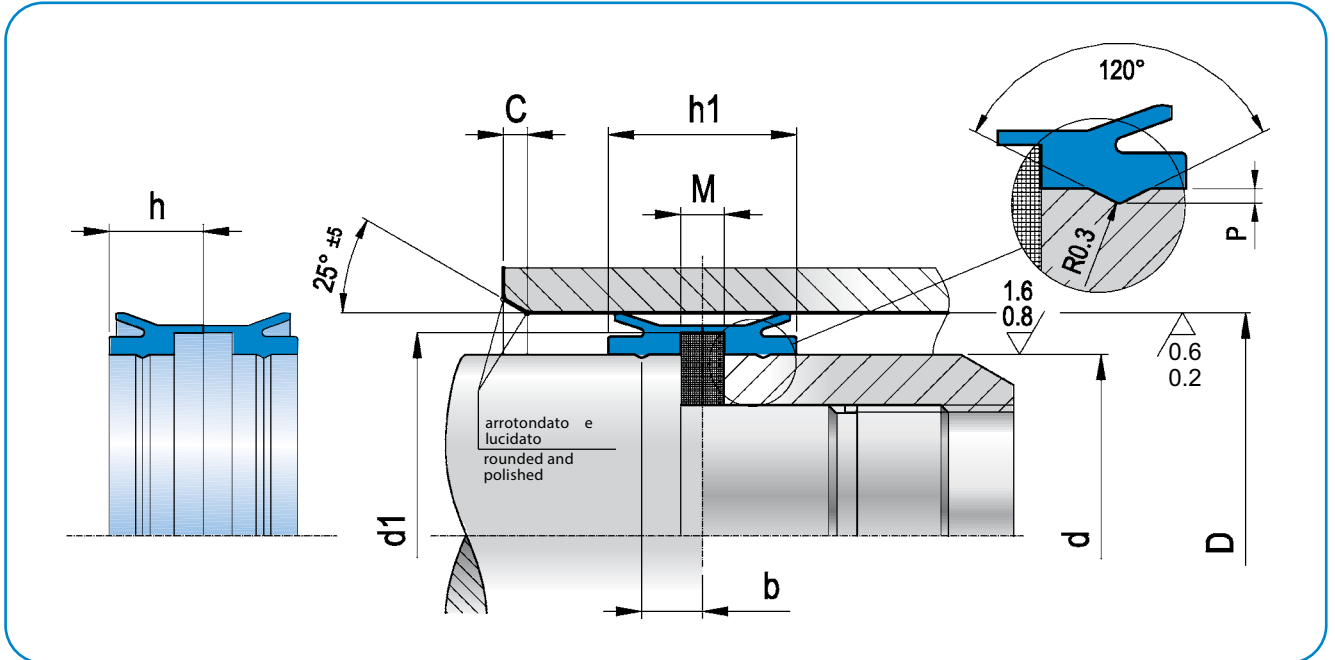
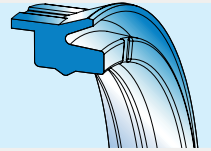

D_{H11}	d_{h9}		h_1	h	d_1	M	P	b	ART / ITEM					
8,0	4,0	0/-0.030	12,0	6,0	6,5	4,0	0,35	4,00	MPS	0080	0040	040	120	Bo
10,0	4,0	0/-0.030	12,0	6,0	8,5	3,0	0,35	3,50	MPS	0100	0040	030	120	Bo
12,0	6,0	0/-0.030	12,0	6,0	10,5	3,0	0,40	3,50	MPS	0120	0060	030	120	Bo
16,0	8,0	0/-0.036	12,0	6,0	14,5	3,0	0,40	3,50	MPS	0160	0080	030	120	Bo
20,0	10,0	0/-0.036	12,0	6,0	18,0	3,0	0,50	3,50	MPS	0200	0100	030	120	Bo
25,0	10,0	0/-0.036	12,0	6,0	23,0	3,0	0,50	3,50	MPS	0250	0100	030	120	Bo

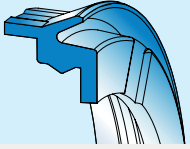

MPS / 2

TENUTA PISTONE MAGNETICO TIPO MPS

Descrizione

La guarnizione tipo MPS è stata studiata sia per pistoni di cilindri pneumatici compatti a corsa breve sia per il semplice e doppio effetto. L'elemento di guida è sulla guarnizione stessa. Appositi interstizi e notches creano spazi per trattenere il grasso lubrificante mantenendo elevata la scorrevolezza del pistone nel tempo.

Il magnete è alloggiato all'interno tra le due guarnizioni contrapposte. Specifiche progettuali personalizzate sono a disposizione per soluzioni alternative.

Limiti d'impiego

Pressione: < 20 bar
 Velocità: < 1 m/s
 Temperatura: da -40° C a +90° C
 Fluidi: aria con o senza lubrificazione, oli e grassi minerali (v. tabella 3 a p. 14)

Materiale

Materiale standard poliuretano a 90 Shore A.
 Codice materiale standard: Bo
 Materiale alternativo poliuretano a 85 Shore A.
 Codice materiale alternativo: Ao

Montaggio

Eliminare tutti gli spigoli vivi e le bave nella sede del pistone per evitare di compromettere la guarnizione. Il montaggio si effettua per accavallamento della guarnizione sul diametro del pistone che deve essere sagomato esattamente come da disegno della tabella dimensionale MPS. Eseguire uno smusso sulla camicia del cilindro.

MPS TYPE MAGNETIC PISTON SEAL

Description

The MPS seal has been specifically designed either for pneumatic compact short stroke cylinders and single/double effect cylinders.

The guiding element is integrated on the seal. Specific notches keep the lubricant grease maintaining a sliding effect on the piston for long time.

The magnet is located between the two opposed gaskets.

For specific needs or problems, our technical office is at your complete disposal with tailor-made solutions.

Technical data

Pressure: < 20 bar
 Speed: < 1 m/s
 Temperature: from -40° C up to +90° C
 Fluids: air with or without lubrication, mineral oils or grease
 (see table 3, page 14)

Material

Standard polyurethane 90 Shore A.
 Standard compound reference: Bo
 Alternative polyurethane 85 Shore A.
 Alternative compound reference: Ao

Assembling

It is important to remove flashes or cutting edges in the housing to avoid damages.

The installation is made by overlapping the seal on the piston diameter.

Warning: the piston must be correctly shaped according to the drawing of the MPS dimensions table. The bore must present a lead-in chamfer.



MPS/2

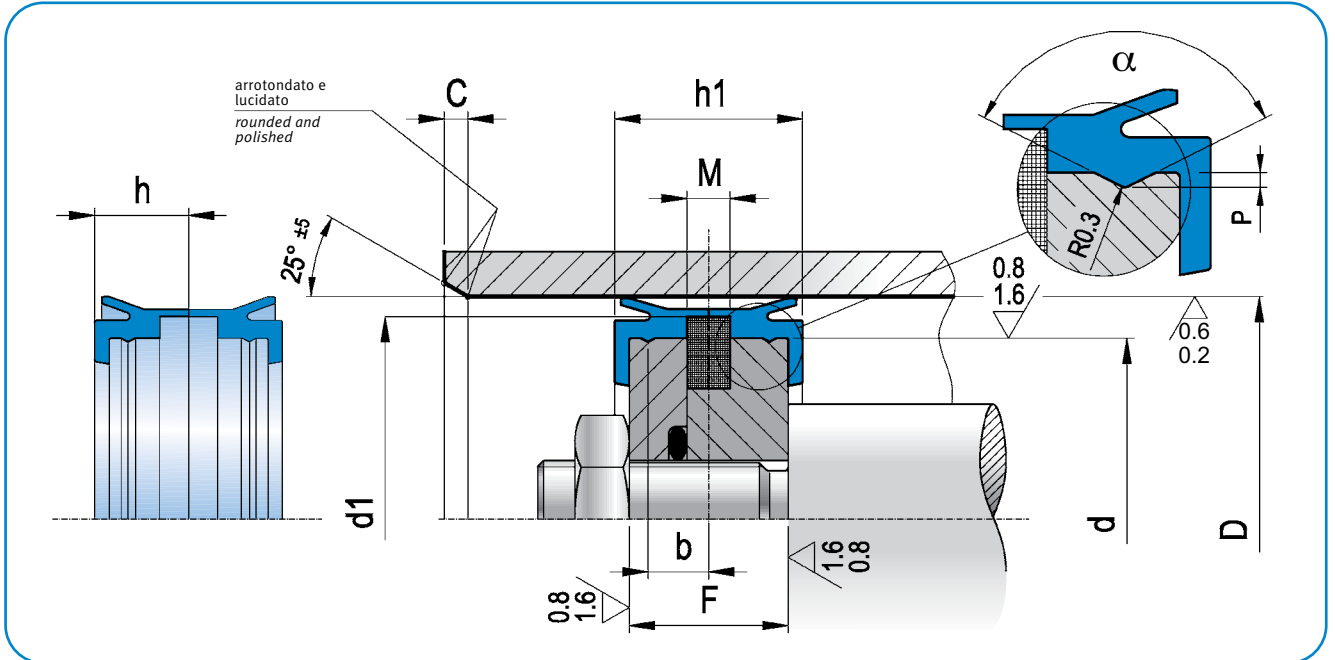
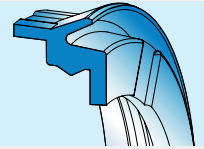

D_{H11}	d_{h9}	Toll h_9	h_1	h	d_1	M	P	b	F	α	ART / ITEM					
32,0	26,0	0/-0.052	14,0	7,00	29,5	3,0	0,50	4,00	11,00	120°	MPS	0320	0260	030	120	Bo
32,0	26,0	0/-0.052	14,0	7,00	29,5	3,0	0,80	4,00	11,00	90°	MPS	0320	0260	030	090	Bo
32,0	26,0	0/-0.052	14,0	7,00	29,5	5,0	0,50	4,00	11,00	120°	MPS	0320	0260	050	120	Bo
32,0	26,0	0/-0.052	14,0	7,00	29,5	5,0	0,80	4,00	11,00	90°	MPS	0320	0260	050	090	Bo
40,0	34,0	0/-0.062	14,5	7,25	37,5	5,0	0,50	4,25	12,00	120°	MPS	0400	0340	050	120	Bo
40,0	34,0	0/-0.062	14,5	7,25	37,5	5,0	0,80	4,25	12,00	90°	MPS	0400	0340	050	090	Bo
50,0	43,0	0/-0.062	14,5	7,25	46,5	5,0	0,60	4,25	12,00	120°	MPS	0500	0430	050	120	Bo
50,0	43,0	0/-0.062	14,5	7,25	46,5	5,0	0,80	4,25	12,00	90°	MPS	0500	0430	050	090	Bo
63,0	55,0	0/-0.074	20,0	10,00	59,5	5,0	0,80	6,00	17,00	120°	MPS	0630	0550	050	120	Bo
80,0	72,0	0/-0.074	22,0	11,00	76,5	5,0	0,80	6,50	19,00	120°	MPS	0800	0720	050	120	Bo
100,0	90,0	0/-0.087	26,0	13,00	96,5	5,0	0,80	7,50	22,00	120°	MPS	1000	0900	050	120	Bo

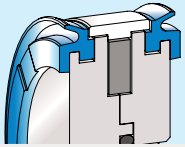

MPM

PISTONE MAGNETICO TIPO MPM

Descrizione

Il pistone magnetico MPM è stato studiato per cilindri pneumatici a doppio effetto dove esiste la necessità di controllare la corsa del pistone/stelo tramite la presenza di un anello magnetico all'interno del pistone stesso. Il pistone magnetico MPM, rispetto ai tradizionali pistoni monoblocco in NBR, ha il vantaggio di mantenere il pistone perfettamente allineato alla sede grazie alla presenza dell'anello guida. Inoltre, le due tenute contrapposte in poliuretano garantiscono la buona scorrevolezza del pistone e mantengono il cilindro internamente pulito, anche in presenza di aria lubrificata.

Il pistone MPM è composto da:

- 2 anelli di tenuta in poliuretano contrapposti fra loro
- 2 anime in alluminio per il corpo centrale del pistone
- 1 elemento magnetico in plastoferrite
- 1 guida per mantenere allineato il pistone
- 1 o-ring in NBR.

I suddetti articoli possono essere forniti assemblati oppure singolarmente.

Limiti d'impiego

Pressione: < 20 bar

Velocità: < 1 m/s

Temperatura: da -40° C a +90° C

Fluidi: aria lubrificata e non, grasso, ecc. (v. tabella 3 a p. 14)

Materiale

Tenute pistone in TPU polietere 85 Shore A e 90 Shore A;
Alluminio ANTICORODAL 6082 per corpo centrale pistone; magnete ANISOTROPICO (plastoferrite orientata); resina acetica additivata PTFE per elemento guida; NBR a 70 Shore A per o-ring interno.

Montaggio

Il montaggio è molto semplice poiché il pistone magnetico è fornito già assemblato nelle sue componenti. Eliminare tutti gli spigoli vivi e/o bave di lavorazione dello stelo per evitare di danneggiare l'o-ring interno.

MAGNETIC PISTON TYPE MPM

Description

The MPM magnetic piston, has been specifically designed for double effect pneumatic cylinders, where it is necessary to control the piston/rod stroke, by a magnetic rings, inside the piston. The MPM magnetic piston, compared with conventional mono-bloc pistons in NBR, has another relevant advantage, thanks to the piston wear ring, which maintains the piston perfectly aligned with the bore. Moreover, the two opposed polyurethane piston seals, ensure a good sliding effect on the piston and maintain the system clean even in the presence of lubricated air.

The MPM magnetic piston, is composed by the following elements:

- 2 Polyurethane seals, opposing each other
- 2 Aluminium parts, for central elements of the piston
- 1 magnetic element in Plastoferrite
- 1 wear ring to maintain the piston axially aligned
- 1 NBR O-ring.

The above mentioned items could be supply assembled or each single part.

Technical data

Pressure: < 20 bar

Speed: < 1 m/s

Temperature: from -40° C up to +90° C

Fluids: Air (lubricated or not), grease, etc. (see table 3, page 14)

Material

Piston seals available in TPU Polyether 85 Shore A and 90 Shore A; Aluminum ANTICORODAL 6082 for central elements; ANISOTROPIC Magnetic Ring (oriented plastoferrite); Acetal Resin (POM) PTFE reinforced for wear ring; NBR 70 Shore A for o-ring.

Assembling

The installation is very easy because the Kit is available already preassembled. It is important to remove flashes or cutting edges on the rod to avoid damages on the O-ring.



MPM

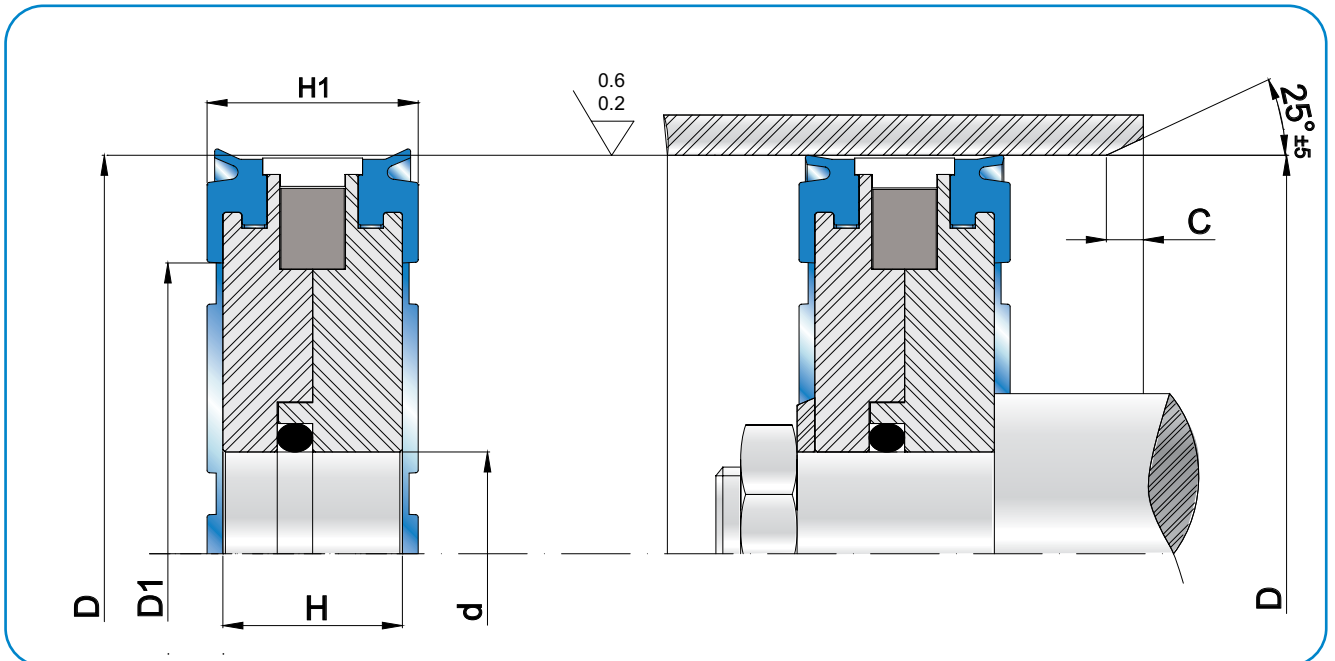
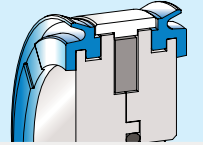

D_{H11}	d_{f9}	H	Max H ₁	Max D ₁	ART / ITEM	85sh	90sh
32,0	8,0	13,0	16,0	22,0	MPM 0320 0080 130	AX	BX
40,0	8,0	13,0	16,0	26,0	MPM 0400 0080 130	AX	BX
40,0	10,0	13,0	16,0	26,0	MPM 0400 0100 130	AX	BX
50,0	10,0	13,0	16,0	35,0	MPM 0500 0100 130	AX	BX
50,0	16,0	13,0	16,0	35,0	MPM 0500 0160 130	AX	BX
60,0	12,0	14,0	17,0	43,0	MPM 0600 0120 140	AX	BX
63,0	12,0	14,0	17,0	46,0	MPM 0630 0120 140	AX	BX
63,0	14,0	14,0	17,0	46,0	MPM 0630 0140 140	AX	BX
63,0	16,0	14,0	17,0	46,0	MPM 0630 0160 140	AX	BX
70,0	12,0	14,0	17,0	54,0	MPM 0700 0120 140	AX	BX
75,0	12,0	14,0	17,0	59,0	MPM 0750 0120 140	AX	BX
80,0	16,0	14,0	17,0	64,0	MPM 0800 0160 140	AX	BX
80,0	18,0	14,0	17,0	64,0	MPM 0800 0180 140	AX	BX
80,0	20,0	14,0	17,0	64,0	MPM 0800 0200 140	AX	BX
90,0	12,0	15,0	18,0	74,0	MPM 0900 0120 150	AX	BX
90,0	16,0	15,0	18,0	74,0	MPM 0900 0160 150	AX	BX
100,0	16,0	16,0	21,0	83,0	MPM 1000 0160 160	AX	BX
100,0	18,0	16,0	21,0	83,0	MPM 1000 0180 160	AX	BX
100,0	20,0	16,0	21,0	83,0	MPM 1000 0200 160	AX	BX

Fig.50:

- 1) tenute Pistone in Poliuretano
- 2) anime Alluminio
- 3) anello magnetico Plastroferrite
- 4) guida Pistone
- 5) O-Ring

Pic.50:

- 1) polyurethane piston seals
- 2) aluminum elements
- 3) magnetic Plastroferrite Ring
- 4) wear Ring
- 5) O-Ring

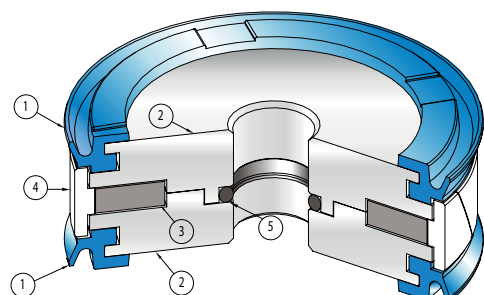

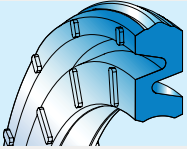

SPS

TENUTA PISTONE A MOLLA TIPO SPS

Descrizione

Realizzata per tenuta pistone di cilindri pneumatici, la guarnizione tipo SPS è utilizzabile anche per valvole pneumatiche, se gli ingombri lo permettono. Le ridotte dimensioni delle sedi consentono un'esecuzione di lavorazione macchina semplice. Il profilo simmetrico, costituito da una tenuta arrotondata al centro sul labbro dinamico e due sporgenze sul labbro statico, ne facilita il montaggio. La particolare forma a molla rende il sistema molto scorrevole anche a bassa pressione.

Limiti d'impiego

Pressione: < 20 bar
 Velocità: < 1 m/s
 Temperatura: da -40° C a +90° C
 Fluidi: aria con o senza lubrificazione, oli e grassi minerali (v. tabella 3 a p. 14)

Materiale

Materiale standard poliuretano a 90 Shore A.
 Codice materiale standard: Bo
 Materiale alternativo poliuretano a 85 Shore A.
 Codice materiale alternativo: Ao

Montaggio

Eliminare tutti gli spigoli vivi e le bave sulla camicia per evitare di compromettere la guarnizione.
 Eseguire uno smusso sulla camicia del cilindro.

SPS TYPE SPRING PISTON SEAL

Description

The SPS rod seal has been designed for pneumatic cylinder applications. The SPS can also be used for pneumatic valves where the overall dimensions allowed. Moreover a shorter machining of the system can be obtained thanks to the reduced overall dimensions. The profile is rounded in the middle of the dynamic lip and it has two projections on the static lip. This symmetric shape allows easier installation. The special spring shaped profile ensures high flexibility in the system even at low pressure.

Technical data

Pressure: < 20 bar
 Speed: < 1 m/s
 Temperature: from -40° C up to +90° C
 Fluids: air with or without lubrication, mineral oils or grease
 (see table 3, page 14)

Material

*Standard polyurethane 90 Shore A.
 Standard compound reference: Bo
 Alternative polyurethane 85 Shore A.
 Alternative compound reference: Ao*

Assembling

It is important to remove flashes or cutting edges in the housing to avoid damages. The bore must present a lead-in chamfer.



SPS

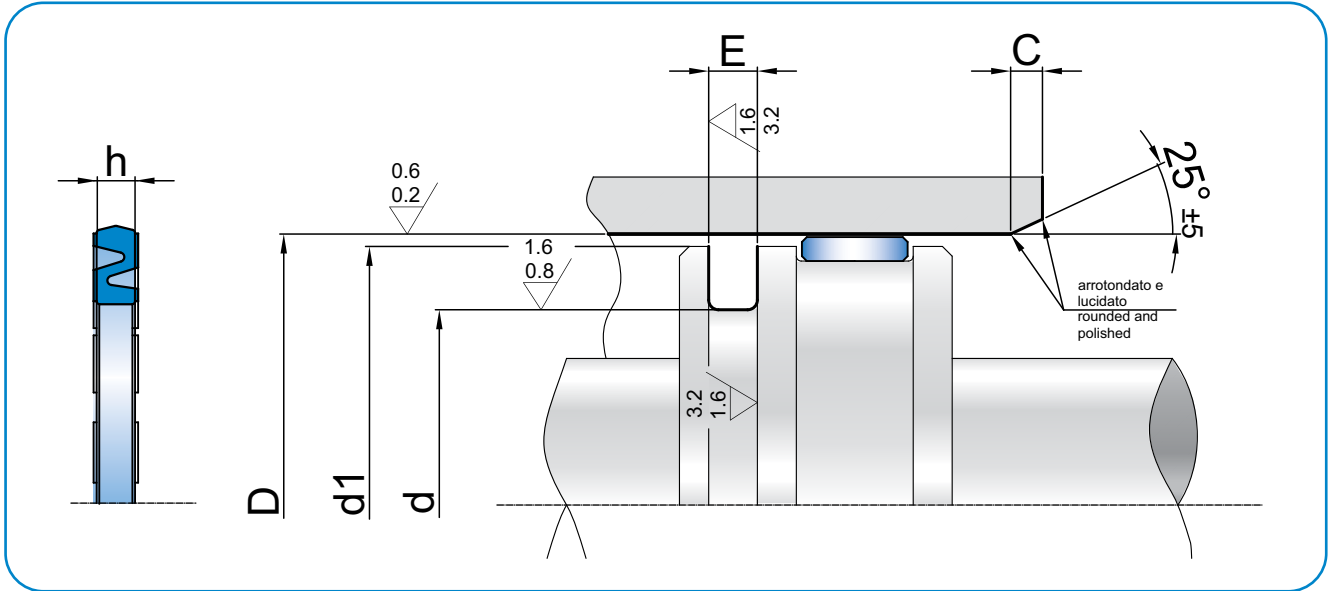
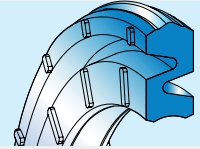

DH11	dh10	toll _{h10}	d1	h	E+0,2	ART / ITEM
12,0	7,0	0/-0.058	11,5	2,2	2,5	SPS 0120 0070 022 Bo
16,0	9,0	0/-0.058	15,5	2,4	2,5	SPS 0160 0090 024 Bo
20,0	13,0	0/-0.070	19,5	2,4	2,5	SPS 0200 0130 024 Bo
25,0	18,0	0/-0.070	24,5	2,4	2,5	SPS 0250 0180 024 Bo
28,0	21,0	0/-0.084	27,5	2,4	2,5	SPS 0280 0210 024 Bo
30,0	21,0	0/-0.084	29,5	2,9	3,0	SPS 0300 0210 029 Bo
32,0	23,0	0/-0.084	31,5	2,9	3,0	SPS 0320 0230 029 Bo
35,0	26,0	0/-0.084	34,5	2,9	3,0	SPS 0350 0260 029 Bo
40,0	31,0	0/-0.100	39,5	2,9	3,0	SPS 0400 0310 029 Bo
45,0	36,0	0/-0.100	44,5	2,9	3,0	SPS 0450 0360 029 Bo
50,0	41,0	0/-0.100	49,5	2,9	3,0	SPS 0500 0410 029 Bo
60,0	48,0	0/-0.100	59,5	3,9	4,0	SPS 0600 0480 039 Bo
63,0	51,0	0/-0.120	62,5	3,9	4,0	SPS 0630 0510 039 Bo
70,0	58,0	0/-0.120	69,5	3,9	4,0	SPS 0700 0580 039 Bo
80,0	68,0	0/-0.120	79,5	3,9	4,0	SPS 0800 0680 039 Bo
100,0	88,0	0/-0.120	99,5	3,9	4,0	SPS 1000 0880 039 Bo

Nota: altre dimensioni non a catalogo a richiesta. Consultare il nostro ufficio tecnico.

Remark: please contact our technical dept. for further dimensions not included in the catalogue.

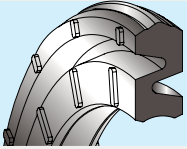

SPS / N

TENUTA PISTONE A MOLLA TIPO SPS/N

Descrizione

Realizzata per tenuta pistone di cilindri pneumatici, la guarnizione tipo SPS/N è utilizzabile anche per valvole pneumatiche dove gli ingombri lo permettono.

Le ridotte dimensioni delle sedi consentono un'esecuzione di lavorazione macchina veloce e semplice.

Il profilo simmetrico ne facilita il montaggio.

La particolare forma a molla rende il sistema molto scorrevole anche a bassissima pressione.

Limiti d'impiego

Pressione: < 12 [bar]

Velocità: < 1 [m/s]

Temperatura: da - 30 °C a +100 °C mescola NBR
da -15 °C a +150 °C mescola FKM

Fluidi: aria lubrificata, grassi e oli minerali (v. tabella 3 a p. 14)

Materiale

Il materiale standard è NBR 80 Shore A.

A richiesta materiale FKM 75 Shore A.

Codice materiale standard: N1

Montaggio

Eliminare spigoli vivi e le bave per non danneggiare la tenuta al momento del montaggio. Eseguire uno smusso sulla camicia del cilindro.

SPS/N TYPE SPRING PISTON SEAL

Description

The seal type SPS / N is a piston seal for pneumatic cylinders.

The SPS/N can also be used for pneumatic valves where the overall dimensions allowed.

The reduced dimensions of the seat allows fast and simple machining operations.

This symmetric profile allows easier installation The special spring shape ensure a system sliding even at very low pressure.

Technical data

Pressure: < 12 [bar]

Speed: < 1 [m/s]

Temperature: from - 30 °C to +100 °C mescola NBR
from -15 °C to +150 °C mescola FKM

Fluids: Lubricated air, grease and mineral oils (see table 3, page 14)

Material

Standard material is NBR 80 Shore A.

On demand material FKM 75 Shore A

Standard compound reference: N1

Assembling

It is important to remove flashes or cutting edges in the housing to avoid damages. The bore must present a lead-in chamfer.



SPS / N

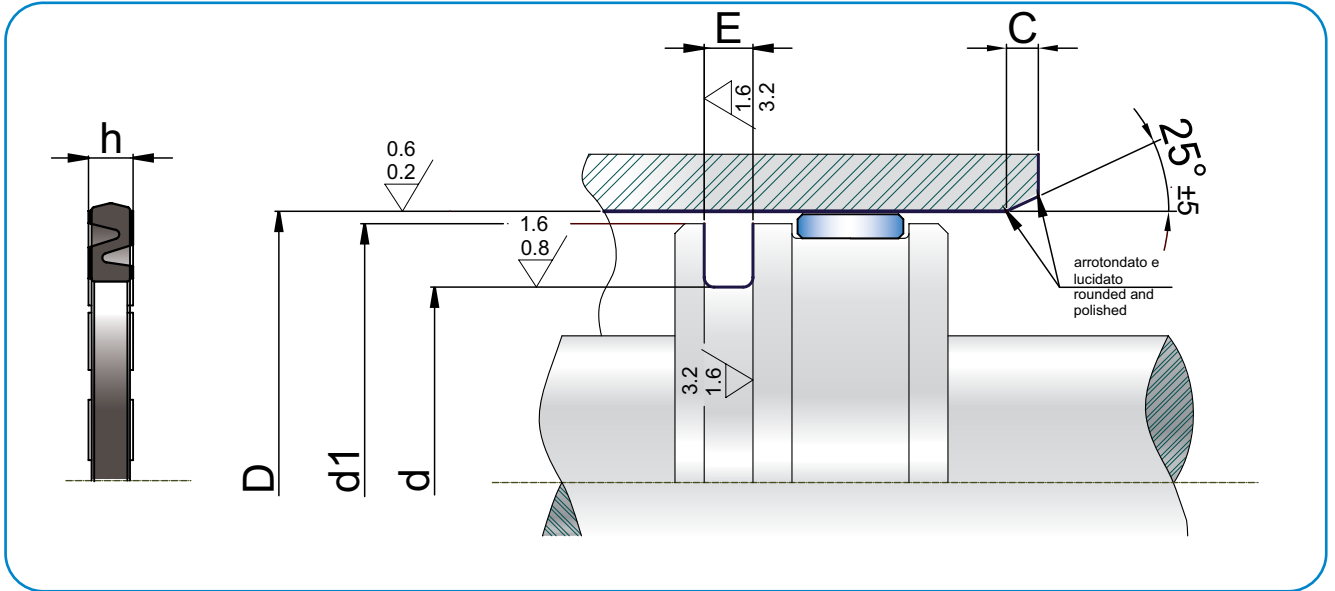
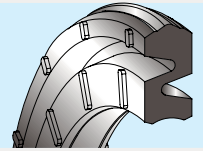

D_{H11}	d_{h10}	toll h_{10}	d_1	h	$E+0,2$	ART / ITEM
12,0	7,0	0/-0,058	11,5	2,20	2,50	SPS 0120 0070 022 N1
16,0	9,0	0/-0,058	15,5	2,40	2,50	SPS 0160 0090 024 N1
20,0	13,0	0/-0,070	19,5	2,40	2,50	SPS 0200 0130 024 N1
25,0	18,0	0/-0,070	24,5	2,40	2,50	SPS 0250 0180 024 N1
28,0	21,0	0/-0,084	27,5	2,40	2,50	SPS 0280 0210 024 N1
30,0	21,0	0/-0,084	29,5	2,90	3,00	SPS 0300 0210 029 N1
32,0	23,0	0/-0,084	31,5	2,90	3,00	SPS 0320 0230 029 N1
35,0	26,0	0/-0,084	34,5	2,90	3,00	SPS 0350 0260 029 N1
40,0	31,0	0/-0,100	39,5	2,90	3,00	SPS 0400 0310 029 N1
45,0	36,0	0/-0,100	44,5	2,90	3,00	SPS 0450 0360 029 N1
50,0	41,0	0/-0,100	49,5	2,90	3,00	SPS 0500 0410 029 N1
60,0	48,0	0/-0,100	59,5	3,90	4,00	SPS 0600 0480 039 N1
63,0	51,0	0/-0,120	62,5	3,90	4,00	SPS 0630 0510 039 N1
70,0	58,0	0/-0,120	69,5	3,90	4,00	SPS 0700 0580 039 N1
80,0	68,0	0/-0,120	79,5	3,90	4,00	SPS 0800 0680 039 N1
100,0	88,0	0/-0,120	99,5	3,90	4,00	SPS 1000 0880 039 N1
125,0	110,0	0/-0,120	124,5	4,90	5,00	SPS 1250 1100 049 N1

Nota: altre dimensioni non a catalogo a richiesta. Consultare il nostro ufficio tecnico.

Remark: please contact our technical dept. for further dimensions not included in the catalogue.

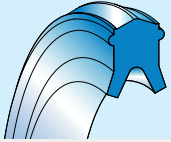

PLF

TENUTA PISTONE TIPO PLF

Descrizione

Nata per ridurre attrito e limitare l'ingombro nel pistone, la tenuta PLF (Pneumatic Low Friction) è una guarnizione per pistoni pneumatici a semplice e a doppio effetto.

Il particolare profilo sfrutta la pressione dell'aria per fare tenuta sia assialmente sia radialmente. Può lavorare a bassa (0,20 Bar) e alta pressione (20 Bar) ed evita lo stick-slip in fase di partenza e durante il movimento alternativo.

Grazie al particolare profilo presenta ridotta usura nel tempo.

Limiti d'impiego

Pressione: < 20 bar

Velocità: < 1 m/s

Temperatura: da -40 °C a +90 °C

Fluidi: aria (con o senza lubrificazione), fluidi e oli a base minerale
(v. tabella 3 a p. 14)

Materiale

Standard: Poliuretano 85 Shore A

Codice materiale: Ao

Montaggio

Il montaggio avviene in cava chiusa e prima di procedere si consiglia di lubrificare con grasso minerale.

È importante togliere le bave di lavorazione che danneggerebbero la tenuta durante il montaggio. Eseguire uno smusso sulla camicia del cilindro.

PISTON SEAL TYPE PLF

Description

The PLF seal "Pneumatic Low Friction" is a single or double effect piston seal, created for Low Friction Working and to have limited dimension of the groove. The particular profile use air pressure, to seal both axially and radially.

It can work at low pressure (0,20 Bar) and high pressure (20 Bar).

No Stick-Slip is in the starting process or during the reciprocating movement.

Thanks to the particular design has a low wear over time.

Technical data

Pressure: < 20 bar

Speed: < 1 m/s

Temperature: from -40 °C to +90 °C

Fluids: air (lubricated or not), mineral-based fluid and oil.
(see table 3, page 14)

Material

Standard: Polyurethane 85 Shore A

Material code: Ao

Assembling

The assembling is in closed groove .

Important is to eliminate burrs, that during the assembly, will damage the seal. Before the assembling is recommended to lubricate with mineral grease. The bore must present a lead-in chamfer.

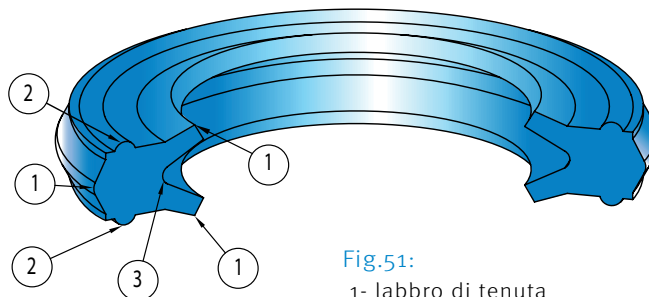

Fig.51:

1- labbro di tenuta
2- distanziale stabilizzatore
3- gola di mantenimento tenuta in pressione

Pic.51:

1- sealing lip
2- spacer stabilizer
3- maintaining pressure sealing groove



PLF

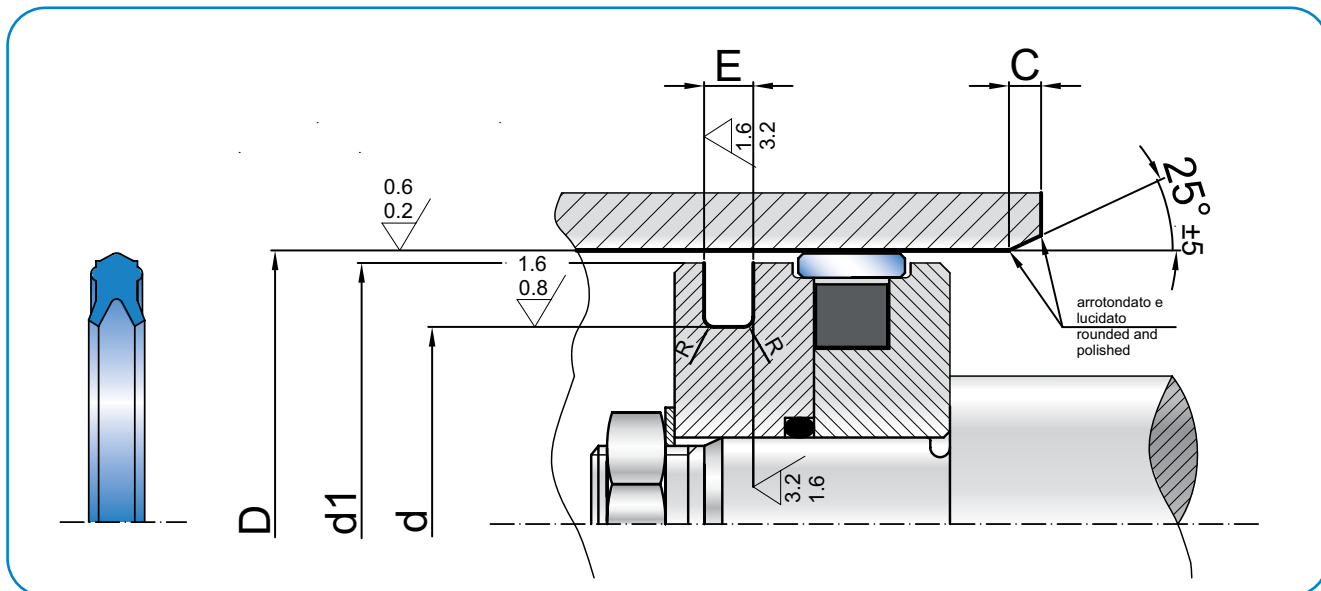
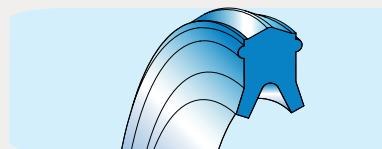

DH ₁₁	dH ₁₀	toll h ₁₀	d ₁	E+0,2	R	ART / ITEM
20,0	13,0	0/-0,070	19,5	2,50	0,20	PLF 0200 0130 025 Ao
25,0	18,0	0/-0,070	24,5	2,50	0,20	PLF 0250 0180 025 Ao
32,0	23,0	0/-0,084	31,5	3,00	0,30	PLF 0320 0230 030 Ao
40,0	31,0	0/-0,100	39,5	3,00	0,30	PLF 0400 0310 030 Ao
50,0	41,0	0/-0,100	49,5	3,00	0,30	PLF 0500 0410 030 Ao
63,0	51,0	0/-0,120	62,5	4,00	0,40	PLF 0630 0510 040 Ao
70,0	58,0	0/-0,120	79,5	4,00	0,40	PLF 0700 0580 040 Ao
80,0	68,0	0/-0,120	79,5	4,00	0,40	PLF 0800 0680 040 Ao
100,0	88,0	0/-0,120	99,5	4,00	0,40	PLF 1000 0880 040 Ao
125,0	110,0	0/-0,120	124,0	5,00	0,50	PLF 1250 1100 050 Ao

Fig.52 - Pic.52:

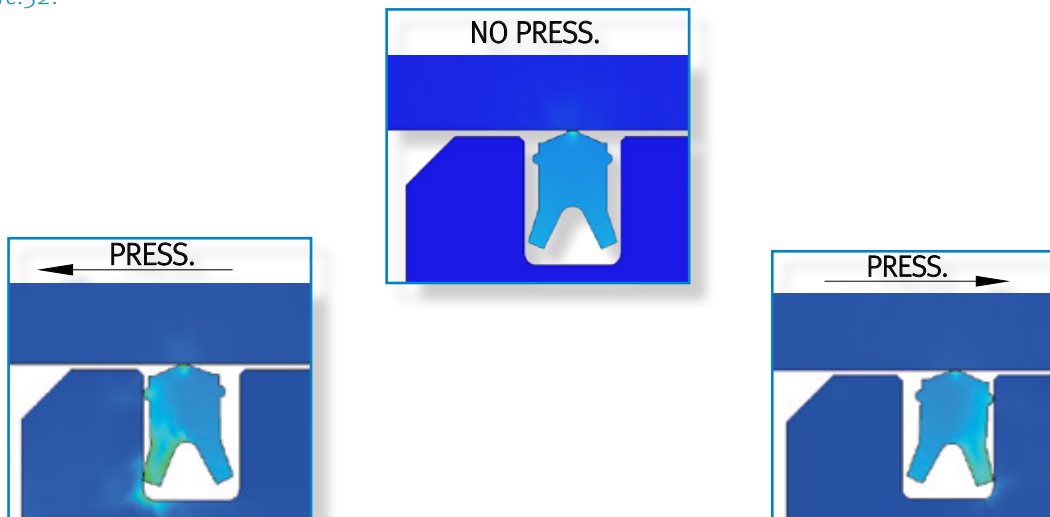

Pneumatica
Pneumatic

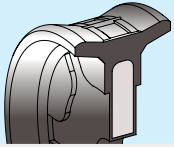

MPP

PISTONE MONOBLOCCO TIPO MPP

Descrizione

Il pistone monoblocco tipo MPP è realizzato in gomma nitrilica di durezza 75 Shore A vulcanizzata su inserto metallico.

Si usa normalmente in applicazioni pneumatiche nei cilindri a semplice e a doppio effetto. Il profilo a labbri di tenuta arrotondati facilita lo scorrimento ed evita il fenomeno di stick-slip. La camera portalubrificante tra i due labbri di tenuta garantisce nel tempo la linearità al movimento assiale. In caso di carichi radiali forti, i distanziali in senso dello scorrimento autoallineano il pistone alla camicia. Nella parte interna, il pistone presenta da entrambi i lati alcuni bassorilievi che facilitano il primo distacco durante l'inversione di marcia.

Dati tecnici

Pressione: < 20 bar
Velocità: < 1 m/s
Temperatura: da - 30° C a + 100° C
Fluidi: aria (lubrificata e non), grasso, ecc.(v. tabella 3 a p.14)

Materiale

Il materiale utilizzato è la combinazione di gomma NBR 75 Shore A con inserto acciaio. È possibile realizzare il pistone in FKM per impieghi ad alte temperature.

Montaggio

Eliminare spigoli vivi all'imbocco camicia-cilindro per evitare di compromettere la guarnizione. Ingrassare il pistone prima del montaggio. Eseguire uno smusso sulla camicia del cilindro.

Importante: si raccomanda di utilizzare rondella di fissaggio sbavata e arrotondata

Fig.53:

- 1 - distanziale per autoallineamento
- 2 - gola porta lubrificante
- 3 - inserto metallico
- 4 - raggio

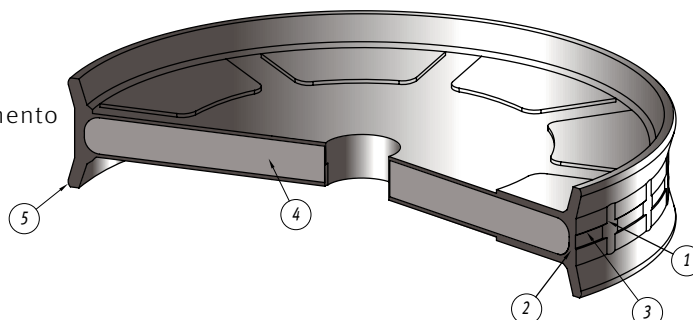

Pic.53:

- 1 - aligning spacer
- 2 - ubricant groove
- 3 - metal insert
- 4 - radius

MONOBLOCK PISTON TYPE MPP

Description

The MPP type mono-block piston type MPP is made of NBR nitrile rubber hardness 75 Shore A vulcanized on a metal insert.

It is normally used in pneumatic applications, in single and double effect cylinders. The profile with rounded edges improves the sliding and avoids Stick-Slip. The groove leads lubricant through the two sealing lips, ensuring the axial movements linearity for long time.

The sliding direction spacers, self-align piston and sleeve in case of heavy radial loads. The piston presents, on both sides of the internal part, some grooves helping breakaway during the first reverse gear.

Technical data

Pressure: < 20 bar
Speed: < 1 m/s
Temperature: from - 30° C up to + 100° C
Fluids: air (lubricated or not), grase, etc. (see table 3, page 14)

Material

The material used is a combination of nitrile rubber NBR 75 Shore A and steel insert. For high temperature application we could also provide FKM compound instead of NBR compound.

Assembling

Remove sharp edges at the Bore-Cylinder entry to avoid seal damages. Grease the piston before installation. The bore must present a lead-in chamfer.

Important: deburred and rounded fixing washer is recommended



MPP

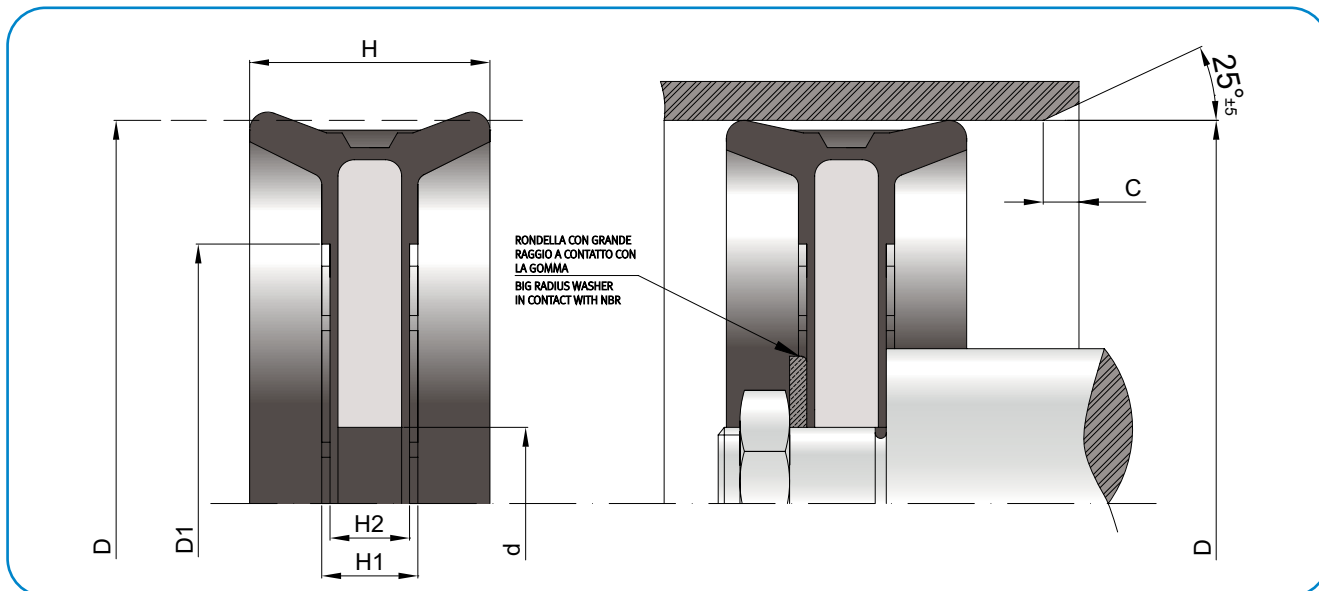
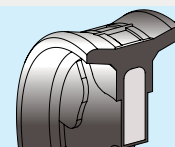

D _{H11}	d _{f8}	H	H ₁	H ₂	C	ART / ITEM				
25,0	8,0	12,0	6,0	4,0	3,00	MPP	0250	0080	120	N2
32,0	8,0	15,0	6,0	4,0	3,00	MPP	0320	0080	150	N2
40,0	10,0	18,0	7,0	5,0	3,00	MPP	0400	0100	180	N2
50,0	10,0	18,0	7,0	5,0	4,00	MPP	0500	0100	180	N2
60,0	12,0	22,0	9,0	6,0	4,00	MPP	0600	0120	220	N2
63,0	12,0	22,0	9,0	6,0	4,00	MPP	0630	0120	220	N2
63,0	14,0	22,0	9,0	6,0	4,00	MPP	0630	0140	220	N2
63,0	16,0	22,0	9,0	6,0	4,00	MPP	0630	0160	220	N2
70,0	12,0	22,0	9,0	6,0	4,00	MPP	0700	0120	220	N2
75,0	12,0	25,0	9,0	6,0	4,50	MPP	0750	0120	250	N2
80,0	12,0	25,0	9,0	6,0	4,50	MPP	0800	0120	250	N2
80,0	14,0	25,0	9,0	6,0	4,50	MPP	0800	0140	250	N2
80,0	16,0	25,0	9,0	6,0	4,50	MPP	0800	0160	250	N2
80,0	18,0	25,0	9,0	6,0	4,50	MPP	0800	0180	250	N2
90,0	12,0	25,0	9,0	6,0	4,50	MPP	0900	0120	250	N2
95,0	12,0	25,0	9,0	6,0	4,50	MPP	0950	0120	250	N2
100,0	18,0	25,0	9,0	6,0	4,50	MPP	1000	0180	250	N2
100,0	20,0	25,0	9,0	6,0	4,50	MPP	1000	0200	250	N2
110,0	12,0	25,0	9,0	6,0	4,50	MPP	1100	0120	250	N2
125,0	18,0	30,0	12,0	9,0	5,00	MPP	1250	0180	300	N2
125,0	20,0	30,0	12,0	9,0	5,00	MPP	1250	0200	300	N2
160,0	20,0	30,0	14,0	12,0	6,00	MPP	1600	0200	300	N2
160,0	24,0	30,0	14,0	12,0	6,00	MPP	1600	0240	300	N2
200,0	20,0	30,0	14,0	12,0	6,00	MPP	2000	0200	300	N2
200,0	24,0	30,0	14,0	12,0	6,00	MPP	2000	0240	300	N2
250,0	30,0	35,0	18,0	16,0	6,00	MPP	2500	0300	350	N2

NB: quota D₁ su richiesta (contattare ufficio tecnico)

NB: dimension D₁ on request (contact technical department)

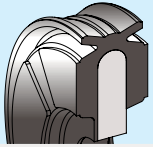

MPC

PISTONE MONOBLOCCO CORTO TIPO MPC

Descrizione

Il pistone corto monoblocco tipo MPC è realizzato in gomma nitrilica di durezza 75 Shore A vulcanizzata su inserto metallico.

Si usa normalmente in applicazioni pneumatiche nei cilindri a semplice e a doppio effetto. Il profilo a labbri di tenuta arrotondati facilita lo scorrimento ed evita il fenomeno di stick-slip. La camera tra i due labbri di tenuta creata come distanziale garantisce nel tempo la linearità al movimento assiale.

La parte interna, sporgente rispetto ai labbri, funge da ammortizzo e presenta da entrambi i lati alcuni bassorilievi che facilitano il primo distacco durante l'inversione di marcia.

Dati tecnici

Pressione: < 20 bar
 Velocità: < 1 m/s
 Temperatura: da - 30° C a + 100° C
 Fluidi: aria (lubrificata e non), grasso, ecc.(v. tabella 3 a p.14)

Materiale

Il materiale utilizzato è la combinazione di gomma NBR 75 Shore A con inserto acciaio. È possibile realizzare il pistone in FKM per impieghi ad alte temperature.

Montaggio

Eliminare spigoli vivi all'imbocco camicia-cilindro per evitare di compromettere la guarnizione.

Ingrassare il pistone prima del montaggio. Eseguire uno smusso sulla camicia del cilindro.

Importante: si raccomanda di utilizzare rondella di fissaggio

Fig.54:

- 1 - distanziale per autoallineamento
- 2 - ammortizzo
- 3 - gola porta lubrificante
- 4 - inserto metallico
- 5 - raggio

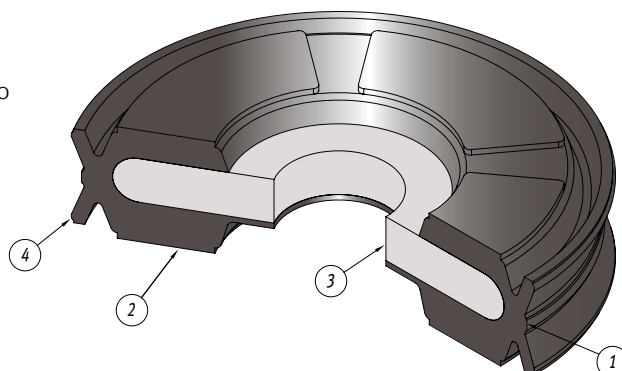

Pic.54:

- 1 - aligning spacer
- 2 - cushioning
- 3 - metal insert
- 4 - radius

SHORT MONOBLOCK PISTON TYPE MPC

Description

The MPC type short mono-block piston type MPP is made of NBR nitrile rubber hardness 75 Shore A vulcanized on a metal insert.

It is normally used in pneumatic applications, in single and double effect cylinders. The profile with rounded edges improves the sliding and avoids Stick-Slip. The groove leads through the two sealing lips as a spacer, ensuring the axial movements linearity for long time.

The internal part of the piston is larger than the lips and its function is cushioning and presents, on both sides, some grooves helping breakaway during the first reverse gear.

Technical data

Pressure: < 20 bar
 Speed: < 1 m/s
 Temperature: from - 30° C up to + 100° C
 Fluids: air (lubricated or not), grase, etc. (see table 3, page 14)

Material

The material used is a combination of nitrile rubber NBR 75 Shore A and steel insert.

For high temperature application we could also provide FKM compound instead of NBR compound.

Assembling

Remove sharp edges at the Bore-Cylinder entry to avoid seal damages.

Grease the piston before installation. The bore must present a lead-in chamfer.

Important: fixing washer is recommended



MPC

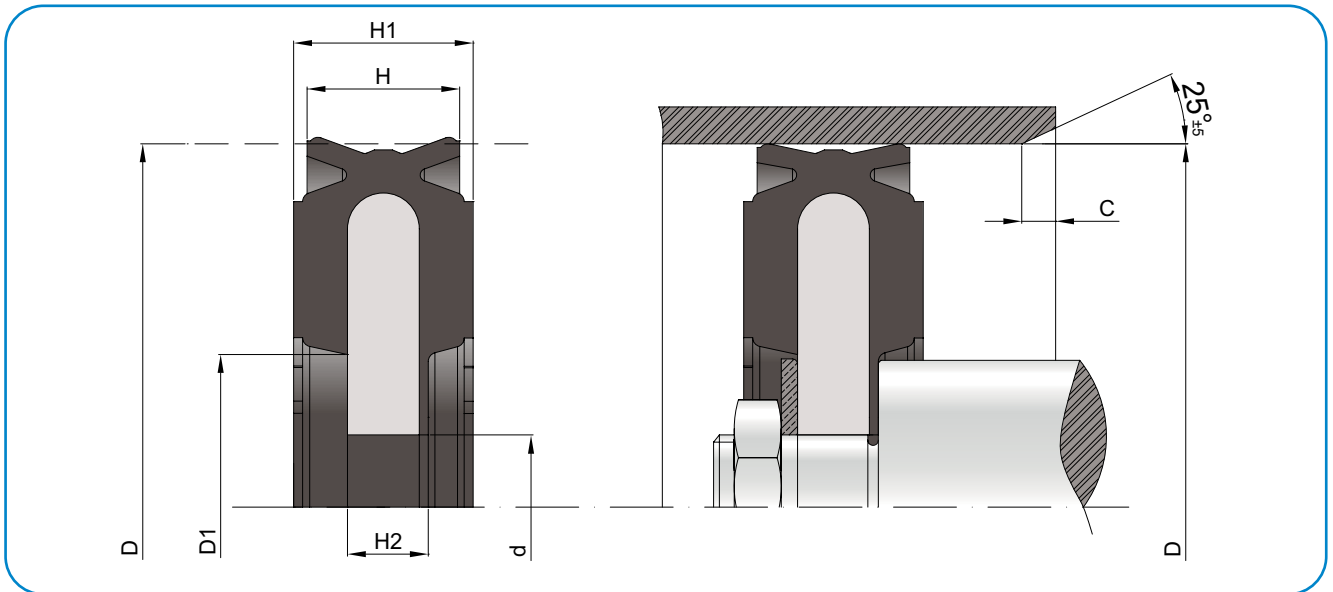
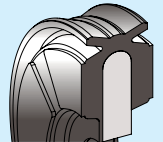

D_{H11}	d_{f8}	H	H1	H2	C	ART / ITEM				
8,0	3,0	4,2	2,1	1,8	3,00	MPC	0080	0030	042	N2
10,0	3,0	4,2	5,2	1,8	3,00	MPC	0100	0030	042	N2
12,0	4,5	5,2	6,2	2,3	3,00	MPC	0120	0045	052	N2
16,0	4,5	5,7	6,7	2,3	4,00	MPC	0160	0045	057	N2
20,0	6,0	6,7	7,7	2,8	4,00	MPC	0200	0060	067	N2
25,0	7,0	8,0	9,0	3,3	4,00	MPC	0250	0070	080	N2
32,0	8,0	8,0	9,0	4,5	4,00	MPC	0320	0080	080	N2
35,0	10,0	8,5	10,0	4,5	4,00	MPC	0350	0100	085	N2
40,0	10,0	8,5	10,0	4,5	4,00	MPC	0400	0100	085	N2
50,0	10,0	8,5	10,0	4,5	4,00	MPC	0500	0100	085	N2
63,0	16,0	9,5	12,0	5,5	4,50	MPC	0630	0160	095	N2
80,0	16,0	9,5	12,0	5,5	4,50	MPC	0800	0160	095	N2
100,0	16,0	12,5	15,0	8,5	4,50	MPC	1000	0160	125	N2

NB: quota D1 su richiesta (contattare ufficio tecnico)

NB: dimension D1 on request (contact technical department)

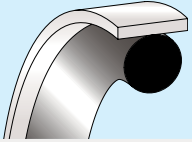

PSN

TENUTA PISTONE TIPO PSN

Descrizione

La tenuta pistone tipo PSN è stata studiata per impieghi pneumatici e oleodinamici e può essere montata anche su pistone di tipo monoblocco grazie alla sua elasticità. La sua caratteristica principale è l'eccezionale scorrevolezza che consente l'impiego anche con fluidi a basso potere lubrificante come aria e acqua.

Innumerevoli test hanno confermato l'assenza di estrusione del profilo anche con passaggio della tenuta sui fori di drenaggio.

Dati Tecnici

Pressione: da 1 a 20 bar
 Velocità: < 4 m/s
 Temperatura: - 30° C a + 120° C,
 Fluidi: aria lubrificata e non (v. tabella 3 a p. 14)

Materiale

Il materiale utilizzato per l'elemento di tenuta è un tecnopolimero ad alta elasticità, mentre si utilizza un o-ring in NBR 75 Shore A per l'elemento energizzante.

In alternativa, per la tenuta si può utilizzare PTFE rinforzato carbografite, mentre per l'elemento energizzante o-ring in materiali quali HNBR o FKM.

Montaggio

Il montaggio avviene in sede anulare in modo elastico.

Eliminare le bave di lavorazione meccanica e lubrificare la tenuta con grasso. Eseguire uno smusso sulla camicia del cilindro.

PSN TYPE PISTON SEAL

Description

The PSN type piston seal has been designed for both pneumatic and hydraulic applications.

Due to its elasticity can also be assembled on monoblock piston type.

Its main characteristic is an exceptional smoothness that allows to use this seal even with low lubricity fluids such as air and water.

many tests have given positive results as regards the absence of extrusion of the profile even with the passage of the seal on the drainage holes of the system.

Technical data

Pressure: da 1 a 20 bar
 Speed: < 4 m/s
 Temperature: from - 30° C up to + 120° C
 Fluids : air (lubricated and not)
 (see table 3, page 14)

Material

The material of the sealing element is a polymer with high elasticity, while as for the energizing element using an O-ring in NBR 75 Shore A.

Alternative material should be use for sealing PTFE filled carbon-graphite, while for the element energizing O-ring materials such as HNBR or FKM.

Assembling

Installation is in elastic way in anular housing.

Remove the burrs mechanical and lubricate the seal with grease. The bore must present a lead-in chamfer.



PSN

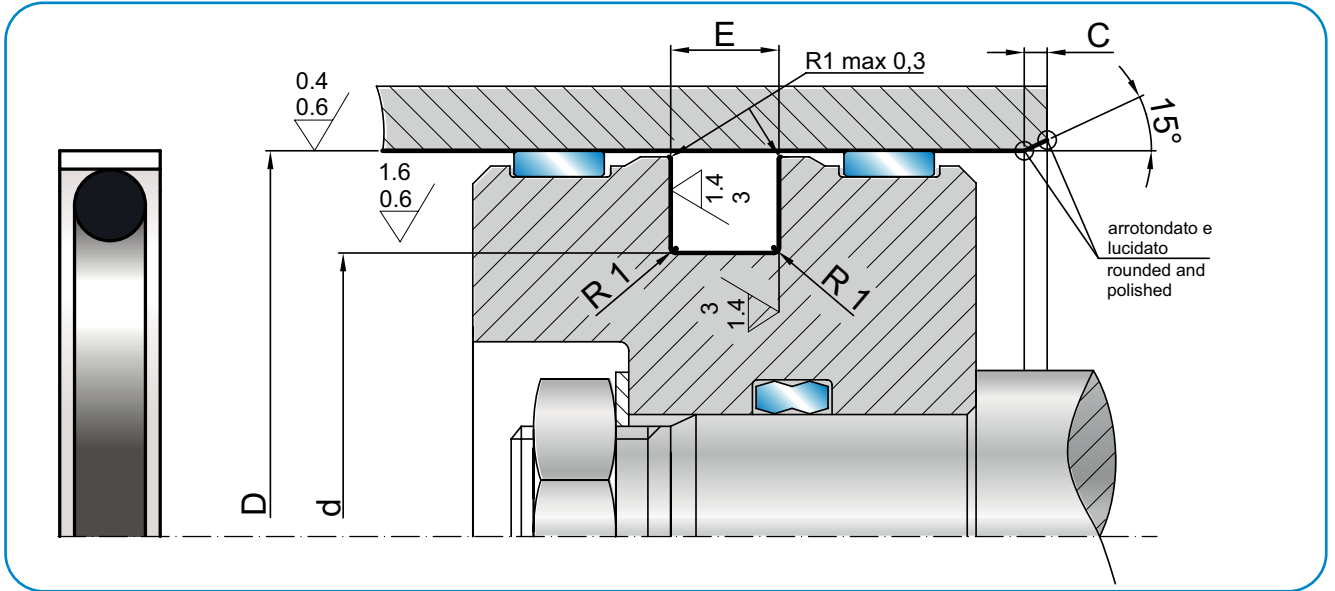
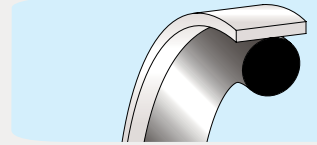

D _{H9}	d _{h9}	E _{+0,2}	O-Ring	C	ART / ITEM
20,00	13,80	3,0	615	5,0	PSN 0200 0138 030 RN
22,00	15,80	3,0	616	5,0	PSN 0220 0158 030 RN
25,00	18,80	3,0	617	5,0	PSN 0250 0188 030 RN
28,00	20,00	4,0	210	5,0	PSN 0280 0200 040 RN
30,00	22,00	4,0	211	5,0	PSN 0300 0220 040 RN
32,00	24,00	4,0	213	5,0	PSN 0320 0240 040 RN
35,00	27,00	4,0	215	5,0	PSN 0350 0270 040 RN
36,00	28,00	4,0	215	5,0	PSN 0360 0280 040 RN
38,00	30,00	4,0	216	5,0	PSN 0380 0300 040 RN
40,00	32,00	4,0	218	5,0	PSN 0400 0320 040 RN
42,00	34,00	4,0	218	5,0	PSN 0420 0340 040 RN
45,00	37,00	4,0	221	5,0	PSN 0450 0370 040 RN
48,00	40,00	4,0	222	5,0	PSN 0480 0400 040 RN
50,00	38,30	6,0	325	5,0	PSN 0500 0383 060 RN
55,00	43,50	6,0	326	5,0	PSN 0550 0435 060 RN
56,00	44,30	6,0	327	5,0	PSN 0560 0443 060 RN
60,00	48,30	6,0	328	5,0	PSN 060 0483 060 RN
63,00	51,30	6,0	329	5,0	PSN 0630 0513 060 RN

D _{H9}	d _{h9}	E _{+0,2}	O-Ring	C	ART / ITEM
65,00	53,30	6,0	329	5,0	PSN 0650 0533 060 RN
70,00	58,40	6,0	331	5,0	PSN 0700 0584 060 RN
75,00	62,90	6,0	332	5,0	PSN 0750 0629 060 RN
80,00	68,00	6,0	334	5,0	PSN 0800 0680 060 RN
85,00	72,90	6,0	336	5,0	PSN 0850 0729 050 RN
90,00	78,00	6,0	337	5,0	PSN 0900 0780 060 RN
95,00	82,90	6,0	339	5,0	PSN 0950 0829 060 RN
100,00	88,00	6,0	340	5,0	PSN 1000 0880 060 RN
110,00	97,90	6,0	343	7,0	PSN 1100 0979 060 RN
120,00	107,90	6,0	346	7,0	PSN 1200 1079 060 RN
125,00	112,50	6,0	348	7,0	PSN 1250 1125 060 RN
130,00	117,50	6,0	349	7,0	PSN 1300 1175 060 RN
140,00	124,50	8,0	428	7,0	PSN 1400 1245 080 RN
160,00	144,20	8,0	434	7,0	PSN 1600 1442 080 RN
180,00	163,70	8,0	874	7,0	PSN 1800 1637 080 RN
200,00	183,70	8,0	880	7,0	PSN 2000 1837 080 RN
250,00	233,70	8,0	447	10,0	PSN 2500 2337 080 RN

Nota: altre dimensioni non a catalogo a richiesta. Consultare il nostro ufficio tecnico.

Remark: please contact our technical dept. for further dimensions not included in the catalogue.

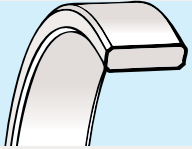

ISA

FASCE DI GUIDA PER STELO TIPO ISA

Descrizione

Per evitare il contatto diretto tra lo stelo e la testata del cilindro, e tra il pistone e la camicia, che nella maggior parte dei cilindri pneumatici è di alluminio, si inserisce una fascia di guida tipo ISA che tiene guidato tutto il sistema.

Le fasce di guida sono stampate con un materiale autolubrificante, non abrasivo e studiato per favorire uno scorrimento lineare. Il profilo della guida presenta smussi interni ed esterni che facilitano il montaggio di stelo e pistone.

Limiti d'impiego

Velocità: < 1 m/s

Temperatura: da - 40° C a + 115° C

Materiale

Resina poliacetalica modificata.

Grazie all'aggiunta di particolari additivi il materiale è molto scorrevole e non abrasivo.

Codice materiale standard: R3

Vantaggi

- ottimo rapporto prezzo/prestazioni
- basso effetto stick-slip
- buona resistenza alla compressione.

Montaggio

Grazie alle guide tagliate il montaggio si esegue facilmente.

Nota: sezione tecnica guide p.158

ISA TYPE ROD GUIDE RING

Description

The ISA type rod guide ring is used to avoid direct contact between cylinder head and rod, and between piston and sleeve, since for the main part of the pneumatic cylinders are made of aluminium. It's also used to lead all the system.

The guide rings are moulded in non-abrasive and self-lubricant material, especially studied to improve the linear sliding.

The profile presents chamfers both sides for easier installation of rod and piston.

Technical data

Speed: < 1 m/s

Temperature: from - 40° C up to + 115° C

Material

Non abrasive modified Polyacetalic resin with additives improving the sliding.

Standard compound reference: R3

Advantages

- excellent price/performance ratio
- low stick-slip effect
- good compressive strength.

Assembling

The assembling can be easily done since the wear ring is cut.

Note: wear rings technical section p.158



ISA

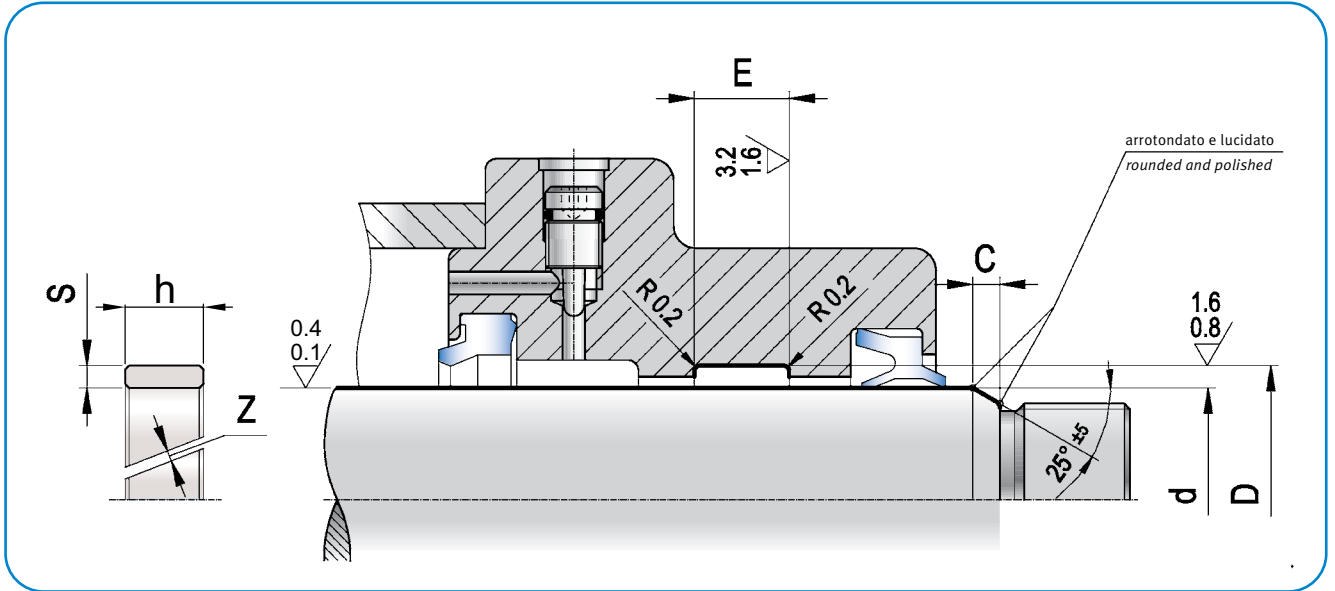
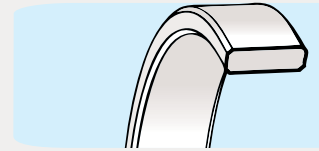

d_{f9}	D_{H7}	toll H_7	$E_{+0,2}$	ART / ITEM			
8,0	11,1	+0.018/0	2,5	ISA	0080	0111	025 R3
10,0	13,1	+0.018/0	2,5	ISA	0100	0131	025 R3
10,0	13,1	+0.018/0	4,0	ISA	0100	0131	040 R3
12,0	15,1	+0.018/0	4,0	ISA	0120	0151	040 R3
12,0	16,0	+0.018/0	9,7	ISA	0120	0160	097 R3
14,0	17,1	+0.018/0	4,0	ISA	0140	0171	040 R3
14,0	18,0	+0.018/0	9,7	ISA	0140	0180	097 R3
15,0	18,1	+0.021/0	4,0	ISA	0150	0181	040 R3
16,0	19,1	+0.021/0	4,0	ISA	0160	0191	040 R3
16,0	20,0	+0.021/0	9,7	ISA	0160	0200	097 R3
17,0	20,1	+0.021/0	4,0	ISA	0170	0201	040 R3
18,0	22,0	+0.021/0	9,7	ISA	0180	0220	097 R3
20,0	23,1	+0.021/0	4,0	ISA	0200	0231	040 R3
22,0	25,1	+0.021/0	4,0	ISA	0220	0251	040 R3
25,0	28,1	+0.021/0	4,0	ISA	0250	0281	040 R3

d_{f9}	D_{H7}	toll H_7	$E_{+0,2}$	ART / ITEM			
28,0	31,1	+0.025/0	4,0	ISA	0280	0311	040 R3
30,0	33,0	+0.025/0	5,6	ISA	0300	0330	056 R3
30,0	33,8	+0.025/0	5,6	ISA	0300	0338	056 R3
30,0	33,1	+0.025/0	4,0	ISA	0300	0331	040 R3
32,0	35,1	+0.025/0	4,0	ISA	0320	0351	040 R3
35,0	38,1	+0.025/0	4,0	ISA	0350	0381	040 R3
36,0	39,1	+0.025/0	4,0	ISA	0360	0391	040 R3
40,0	43,1	+0.025/0	4,0	ISA	0400	0431	040 R3
50,0	53,1	+0.030/0	4,0	ISA	0500	0531	040 R3
55,1	57,9	+0.030/0	4,0	ISA	0551	0579	040 R3
68,0	71,0	+0.030/0	4,0	ISA	0680	0710	040 R3

Nota: altre dimensioni non a catalogo a richiesta. Consultare il nostro ufficio tecnico.

Remark: please contact our technical dept. for further dimensions not included in the catalogue.

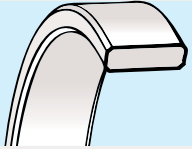

ESA

FASCE DI GUIDA PER PISTONE TIPO ESA

Descrizione

Per evitare il contatto diretto tra lo stelo e la testata del cilindro, e tra il pistone e la camicia, che è in alluminio nella maggior parte dei cilindri pneumatici, si inserisce una fascia di guida tipo ESA per tenere guidato tutto il sistema. Le fasce di guida sono stampate con un materiale autolubrificante, non abrasivo e studiato per favorire uno scorrimento lineare.

Il profilo della guida presenta smussi interni ed esterni che facilitano il montaggio di stelo e pistone.

Limiti d'impiego

Velocità: < 1 m/s

Temperatura: da - 40° C a + 115° C

Materiale

Resina poliacetalica modificata.

Grazie all'aggiunta di particolari additivi il materiale è molto scorrevole e non abrasivo.

Codice materiale standard: R3

Vantaggi

- ottimo rapporto prezzo/prestazioni
- basso effetto stick-slip
- buona resistenza alla compressione.

Montaggio

Grazie alle guide tagliate il montaggio si esegue facilmente.

Nota: sezione tecnica guide p.158

ESA TYPE PISTON GUIDE RING

Description

The ESA type rod guide ring is used to avoid direct contact between cylinder head and rod, and between piston and sleeve, since for the main part of the pneumatic cylinders are made of aluminium. It's also used to lead all the system.

The guide rings are moulded in non-abrasive and self-lubricant material, especially studied to improve the linear sliding.

The profile presents chamfers both sides for easier installation of rod and piston.

Technical data

Speed: < 1 m/s

Temperature: from - 40° C up to + 115° C

Material

Non abrasive modified Polyacetalic resin with additives improving the sliding.

Standard compound reference: R3

Advantages

- excellent price/performance ratio
- low stick-slip effect
- good compressive strength.

Assembling

The assembling can be easily done since the wear ring is cut.

Note: wear rings technical section p.158



ESA

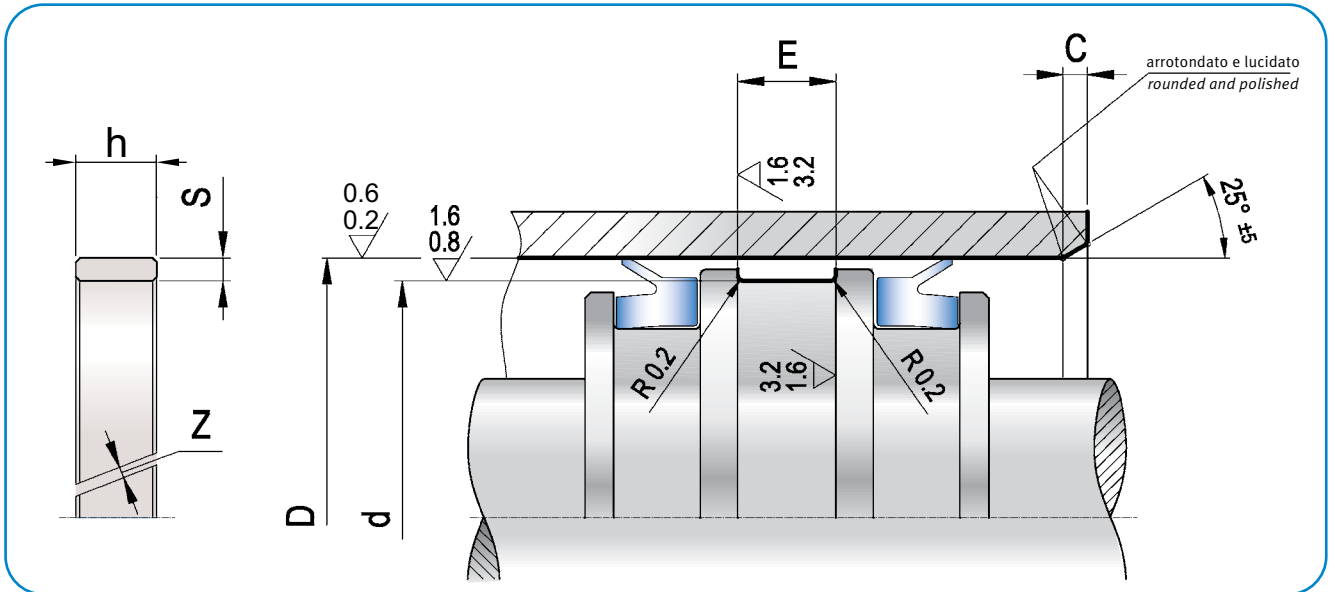
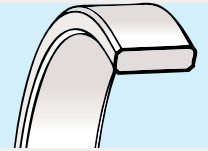

D _{H11}	d _{h7}	toll _{h7}	E _{+0,2}	ART / ITEM
8,0	4,9	0/-0.012	2,5	ESA 0080 0049 025 R3
10,0	6,9	0/-0.015	2,5	ESA 0100 0069 025 R3
10,0	6,9	0/-0.015	4,0	ESA 0100 0069 040 R3
12,0	8,9	0/-0.015	4,0	ESA 0120 0089 040 R3
14,0	10,9	0/-0.018	4,0	ESA 0140 0109 040 R3
15,0	11,9	0/-0.018	4,0	ESA 0150 0119 040 R3
16,0	12,9	0/-0.018	4,0	ESA 0160 0129 040 R3
16,0	12,0	0/-0.018	9,7	ESA 0160 0120 097 R3
18,0	14,9	0/-0.018	4,0	ESA 0180 0149 040 R3
20,0	16,0	0/-0.018	8,2	ESA 0200 0160 082 R3
20,0	16,0	0/-0.018	9,7	ESA 0200 0160 097 R3
20,0	16,9	0/-0.018	4,0	ESA 0200 0169 040 R3
21,0	17,0	0/-0.018	8,2	ESA 0210 0170 082 R3
22,0	18,0	0/-0.018	9,7	ESA 0220 0180 097 R3
25,0	21,0	0/-0.021	8,2	ESA 0250 0210 082 R3
25,0	21,9	0/-0.021	4,0	ESA 0250 0219 040 R3
26,0	22,0	0/-0.021	8,2	ESA 0260 0220 082 R3
30,0	25,8	0/-0.021	5,0	ESA 0300 0258 050 R3
30,0	26,0	0/-0.021	5,0	ESA 0300 0260 050 R3
30,0	26,0	0/-0.021	8,2	ESA 0300 0260 082 R3
30,0	27,0	0/-0.021	,2	ESA 0300 0270 042 R3
32,0	26,1	0/-0.021	5,0	ESA 0320 0261 050 R3
32,0	28,0	0/-0.021	5,0	ESA 0320 0280 050 R3
32,0	28,0	0/-0.021	8,2	ESA 0320 0280 082 R3

Pneumatica
Pneumatic

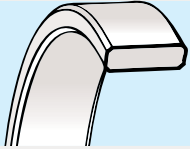

ESA

D _{H11}	d _{h7}	toll _{h7}	E _{+0,2}	ART / ITEM			
32,0	28,9	0/-0.021	4,0	ESA 0320	0289	040	R3
35,0	31,0	0/-0.025	8,2	ESA 0350	0310	082	R3
40,0	36,0	0/-0.025	5,0	ESA 0400	0360	050	R3
40,0	36,0	0/-0.025	8,2	ESA 0400	0360	082	R3
40,0	37,0	0/-0.025	12,0	ESA 0400	0370	120	R3
45,0	41,0	0/-0.025	10,2	ESA 0450	0410	102	R3
50,0	46,0	0/-0.025	5,2	ESA 0500	0460	052	R3
50,0	46,0	0/-0.025	10,2	ESA 0500	0460	102	R3
50,0	47,0	0/-0.025	3,2	ESA 0500	0470	032	R3
50,0	47,0	0/-0.025	12,0	ESA 0500	0470	120	R3
55,0	51,0	0/-0.030	10,2	ESA 0550	0510	102	R3
58,0	54,0	0/-0.030	10,2	ESA 0580	0540	102	R3
60,0	56,0	0/-0.030	10,2	ESA 0600	0560	102	R3
63,0	58,0	0/-0.030	4,2	ESA 0630	0580	042	R3
63,0	59,0	0/-0.030	10,2	ESA 0630	0590	102	R3
63,0	60,0	0/-0.030	3,2	ESA 0630	0600	032	R3
63,0	60,0	0/-0.030	12,0	ESA 0630	0600	120	R3
65,0	61,0	0/-0.030	10,2	ESA 0650	0610	102	R3
70,0	66,0	0/-0.030	10,2	ESA 0700	0660	102	R3
75,0	71,0	0/-0.030	15,2	ESA 0750	0710	152	R3
80,0	76,0	0/-0.030	10,2	ESA 0800	0760	102	R3
80,0	76,0	0/-0.030	15,2	ESA 0800	0760	152	R3
80,0	77,0	0/-0.030	12,0	ESA 0800	0770	120	R3
85,0	81,0	0/-0.035	15,2	ESA 0850	0810	152	R3
90,0	86,0	0/-0.035	15,2	ESA 0900	0860	152	R3
95,0	91,0	0/-0.035	15,2	ESA 0950	0910	152	R3
100,0	96,0	0/-0.035	10,2	ESA 1000	0960	102	R3
100,0	96,0	0/-0.035	15,2	ESA 1000	0960	152	R3
105,0	101,0	0/-0.035	20,3	ESA 1050	1010	203	R3
110,0	106,0	0/-0.035	20,3	ESA 1100	1060	203	R3
115,0	111,0	0/-0.035	20,3	ESA 1150	1110	203	R3
120,0	116,0	0/-0.035	20,3	ESA 1200	1160	203	R3
125,0	121,0	0/-0.040	15,2	ESA 1250	1210	152	R3
125,0	121,0	0/-0.040	20,3	ESA 1250	1210	203	R3
130,0	126,0	0/-0.040	20,3	ESA 1300	1260	203	R3
135,0	131,0	0/-0.040	20,3	ESA 1350	1310	203	R3
140,0	136,0	0/-0.040	20,3	ESA 1400	1360	203	R3
150,0	146,0	0/-0.040	25,4	ESA 1500	1460	254	R3
160,0	155,0	0/-0.040	5,6	ESA 1600	1550	056	R3



ESA

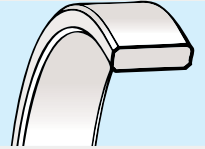

D _{H11}	d _{h7}	toll _{h7}	E _{+0,2}	ART / ITEM				
160,0	155,0	0/-0.040	15,0	ESA	1600	1550	150	R3
160,0	156,0	0/-0.040	15,2	ESA	1600	1560	152	R3
160,0	157,0	0/-0.040	5,6	ESA	1600	1570	056	R3
180,0	176,0	0/-0.040	25,4	ESA	1800	1760	254	R3
200,0	195,0	0/-0.046	15,0	ESA	2000	1950	150	R3
200,0	196,0	0/-0.046	20,3	ESA	2000	1960	203	R3
200,0	196,0	0/-0.046	25,4	ESA	2000	1960	254	R3
220,0	216,0	0/-0.046	30,5	ESA	2200	2160	305	R3
250,0	245,0	0/-0.046	20,0	ESA	2500	2450	200	R3
250,0	246,0	0/-0.046	20,3	ESA	2500	2460	203	R3
250,0	246,0	0/-0.046	30,5	ESA	2500	2460	305	R3

Nota: altre dimensioni non a catalogo a richiesta. Consultare il nostro ufficio tecnico.

Remark: please contact our technical dept. for further dimensions not included in the catalogue.

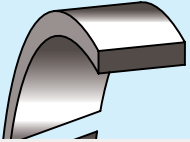

NG

NASTRO GUIDA IN PTFE TIPO NG

Descrizione

Il nastro guida NG in politetrafluoroetilene caricato carbografite è fornito in rotoli dai quali si ricavano guide intercambiabili con quelle in materiale termoplastico. Applicate su stelo e su pistone, le guide hanno come caratteristiche principali la precisione dello spessore e la quasi assenza di attrito. Per la loro inerzia chimica sono compatibili con molti fluidi e possono essere con o senza smussi di invito.

Limiti d'impiego

Velocità: < 15 m/s

Temperatura: da -50°C a +160°C con punte a 200°C

Fluidi: molti fluidi essendo un materiale con inerzia chimica elevata (v. tabella 3 a p. 16)

Materiale

Il materiale è un politetrafluoroetilene (PTFE) con caricato carbografite
Codice materiale: TC LCG3030

Montaggio

Grazie alle guide tagliate il montaggio si esegue facilmente.

Nota: sezione tecnica guide p.158

NG TYPE PTFE WEAR TAPE

Description

NG carbon-graphite filled PTFE tape is supplied in rolls.

By cutting them is possible to obtain interchangeable guides to replace thermoplastic material.

They can be used for rods or pistons.

Thanks to the properties (thickness accuracy, low friction and chemical resistance) are compatible with many fluids.

They can be with or without chamfers.

Technical data

Speed: < 15 m/s

Temperature: from -50°C to +160°C peaks till 200°C.

Fluidi: many fluids as a material with high chemical inertia
(see table 3, page 16)

Material

The material is carbon-graphite filled PTFE.
Compound reference: TC LCG3030

Assembling

The assembling can be easily done since the wear ring is cut.

Note: wear rings technical section p.158



NG

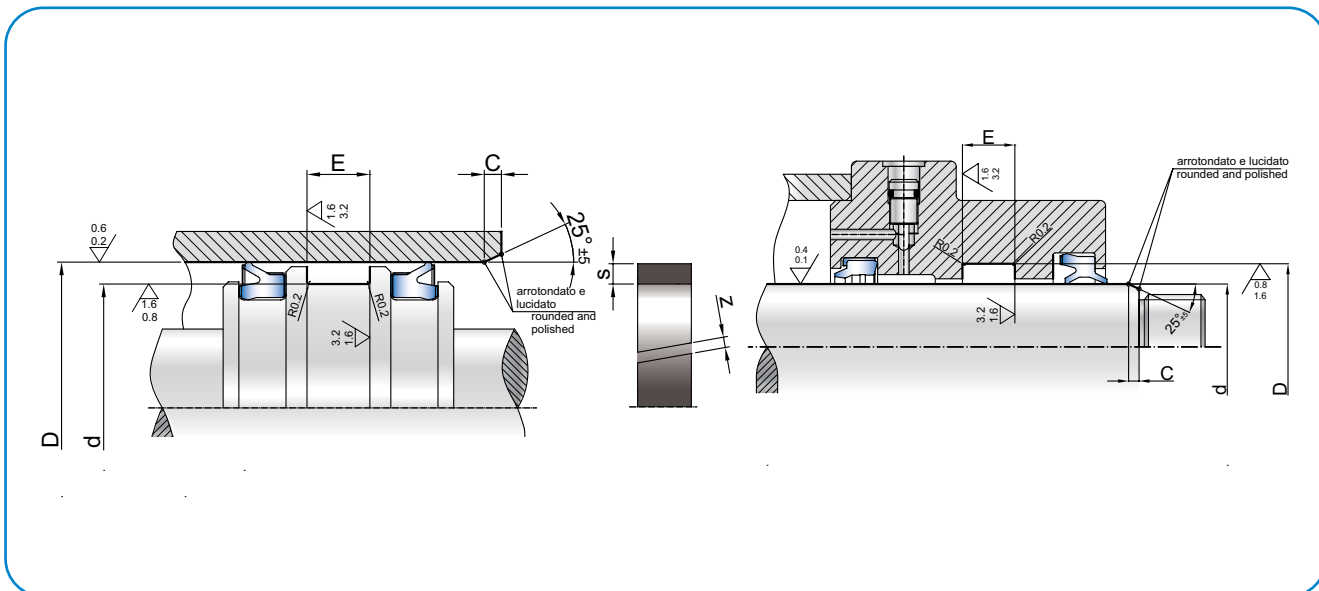
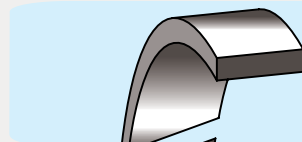

Dimensione sede - Groove dimension				
d_{H9}	D_{H9}	$E_{+0.2}$	Spessore anello Ring thickness s	z
8-20	$d + 2s$	3,20	1,50	1,0-2,0
15-35	$d + 2s$	4,20	1,50 2,00	1,0-2,0
15-75	$d + 2s$	5,60	1,50 2,00 2,50	1,5-3,5
20-75	$d + 2s$	6,30	1,50 2,00 2,50	1,5-3,5
30-250	$d + 2s$	8,10	1,50 2,00 2,50	2,0-5,0
35-300	$d + 2s$	9,70	1,50 2,00 2,50 3,00	2,0-6,0
120-400	$d + 2s$	15,00	1,50 2,00 2,50 3,00	4,0-8,0
200-900	$d + 2s$	20,00	1,50 2,00 2,50 3,00	4,5-8,0
300-900	$d + 2s$	25,00	2,00 2,50 3,00	6,0-8,0
300-900	$d + 2s$	30,00	2,00 2,50 3,00	6,0-10,0

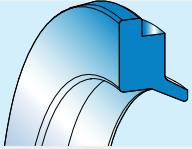

LWA

RASCHIATORE LEGGERO TIPO LWA

Descrizione

Il raschiatore leggero tipo LWA è studiato per tenere pulite le bussole a sfera nelle unità di guida. A contatto con alberi cementati o rettificati nella parte interna, il raschiatore alloggia nella parte esterna sul diametro della bussola mentre l'aggancio è garantito da una gola (tipo quella di un seeger per esterno) in cui si inserisce il gradino del raschiatore.

La lavorazione meccanica di facile esecuzione e l'ingombro minimo hanno esteso il campo di applicazione anche nei cilindri pneumatici. Il labbro molto flessibile del raschiatore non pregiudica la scorrevolezza dell'unità di guida.

Limiti d'impiego

Velocità: < 4 m/s

Temperatura: da - 40° C a + 90° C

Materiale

Il materiale utilizzato è un poliuretano che resiste molto bene all'usura e benissimo alle basse temperature mantenendosi sempre flessibile. Materiale standard poliuretano a 90 Shore A. Codice materiale standard: Bo

Montaggio

Eliminare tutti gli spigoli vivi e le bave nell'alloggiamento del raschiatore.

Si consiglia di ingrassare il sistema. Lo stelo deve avere uno smusso di invito.

LWA TYPE LIGHT WIPER

Description

The LWA type light wiper is designed for the ball-bushings cleaning in the guide systems.

The internal part is in contact with hardened or ground shafts.

The external part is located the outside diameter of the bushing and the hanging is ensured by a groove (similar to a circlip for external use) where the wiper step is inserted.

The field of applications has been enlarged to the pneumatic cylinders thanks to the very simple mechanical execution and the reduced overall dimensions.

The highly flexible wiper lip does not interfere with the sliding of the guide system.

Technical data

Speed: < 4 m/s

Temperature: from - 40° C up to + 90° C

Material

Our polyurethane is very resistant to wear and is excellent at low temperature due to its high flexibility. Standard polyurethane 90 Shore A. Standard compound reference: Bo

Assembling

Remove cutting edges and flashes in the scraper housing.

We recommend greasing the system. The rod must have a lead-in chamfer.



LWA

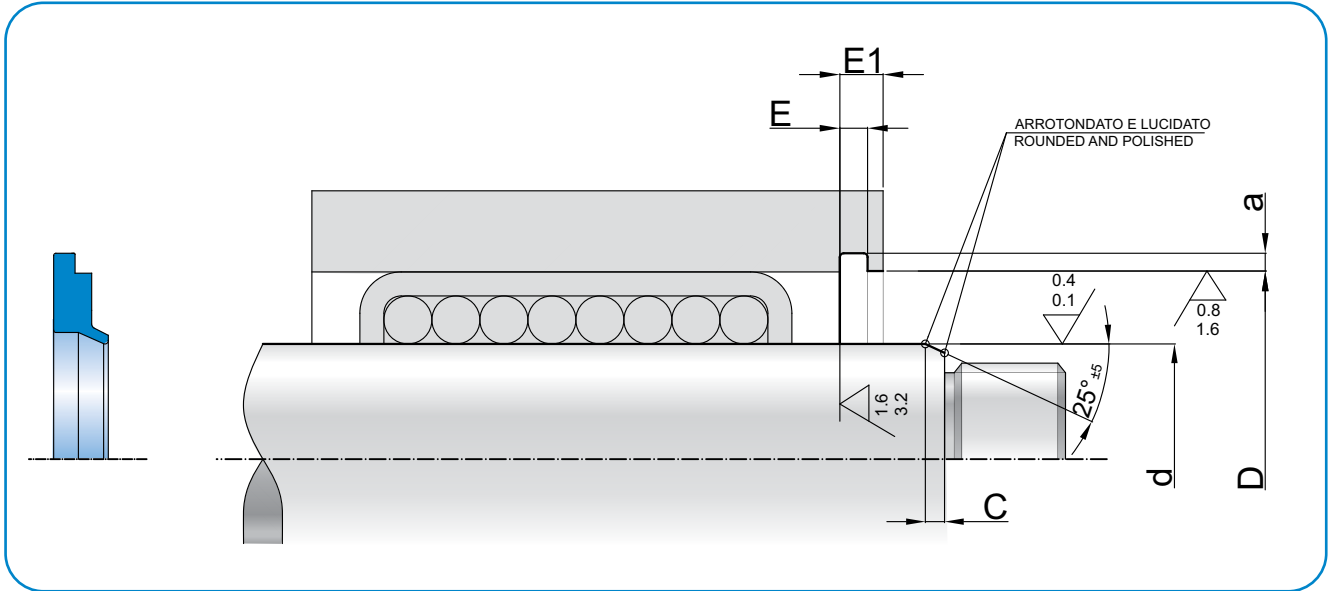
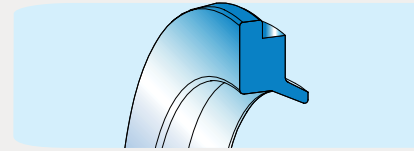

d_{f9}	D_{H11}	tol H_{11}	h	E_1	a	E	ART / ITEM
6,0	12,0	+0.110/-0	4,5	3,0	1,3	1,6	LWA 0060 0120 045 Bo
8,0	15,0	+0.110/-0	4,5	3,0	1,3	1,6	LWA 0080 0150 045 Bo
10,0	17,0	+0.110/-0	4,5	3,0	1,3	1,6	LWA 0100 0170 045 Bo
12,0	19,0	+0.130/-0	4,5	3,0	1,3	1,6	LWA 0120 0190 045 Bo
14,0	21,0	+0.130/-0	4,5	3,0	1,3	1,6	LWA 0140 0210 045 Bo
16,0	24,0	+0.130/-0	4,5	3,0	1,3	1,6	LWA 0160 0240 045 Bo
18,0	23,5	+0.130/-0	4,5	3,0	1,3	1,6	LWA 0180 0235 045 Bo
20,0	28,0	+0.130/-0	4,5	3,0	1,3	1,6	LWA 0200 0280 045 Bo
25,0	35,0	+0.160/-0	4,5	3,0	1,5	1,6	LWA 0250 0350 045 Bo
30,0	40,0	+0.160/-0	4,5	3,0	2,0	1,6	LWA 0300 0400 045 Bo
40,0	52,0	+0.190/-0	4,5	3,0	2,0	1,6	LWA 0400 0520 045 Bo
50,0	62,0	+0.190/-0	4,5	3,0	2,0	1,6	LWA 0500 0620 045 Bo

Nota: altre dimensioni non a catalogo a richiesta. Consultare il nostro ufficio tecnico.

Remark: please contact our technical dept. for further dimensions not included in the catalogue.

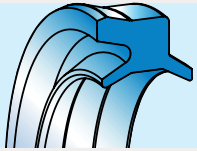

BWA

RASCHIATORE BIDIREZIONALE TIPO BWA

Descrizione

L'elemento di tenuta tipo BWA ha il profilo di una guarnizione a labbri asimmetrici combinato con un raschiatore.

Alloggiato in un'unica sede, presenta ingombri ridotti e minor tempo di esecuzione della sede.

Limiti d'impiego

Pressione: < 20 bar

Velocità: < 1 m/s

Temperatura: da - 40° C a + 90° C

Fluidi: aria con o senza lubrificazione, oli e grassi minerali (v. tabella 3 a p.14)

Materiale

Materiale standard poliuretano a 90 Shore A.

Codice materiale standard: Bo

Materiale alternativo poliuretano a 85 Shore A.

Codice materiale alternativo: Ao

Montaggio

La sede dove alloggia il raschiatore non deve presentare spigoli vivi o bave che compromettano la durata in esercizio.

BWA TYPE BI-DIRECTIONAL WIPER

Description

The BWA sealing part combines an asymmetrical lip seal profile with a wiper.

Since it is installed in a single groove, the BWA seal has several advantages:

- reduced overall dimensions
- faster construction of the groove.

Technical data

Pressure: < 20 bar

Speed: < 1 m/s

Temperature: from - 40° C up to + 90° C

Fluids: air with or without lubrication, mineral oils or grease
(see table 3, page 14)

Material

Standard polyurethane 90 Shore A.

Standard compound reference: Bo

Alternative polyurethane 85 Shore A.

Alternative compound reference: Ao

Assembling

Remove cutting edges and/or flashes from the housing where the wiper has to be installed in order to minimise seal wear during operation.



BWA

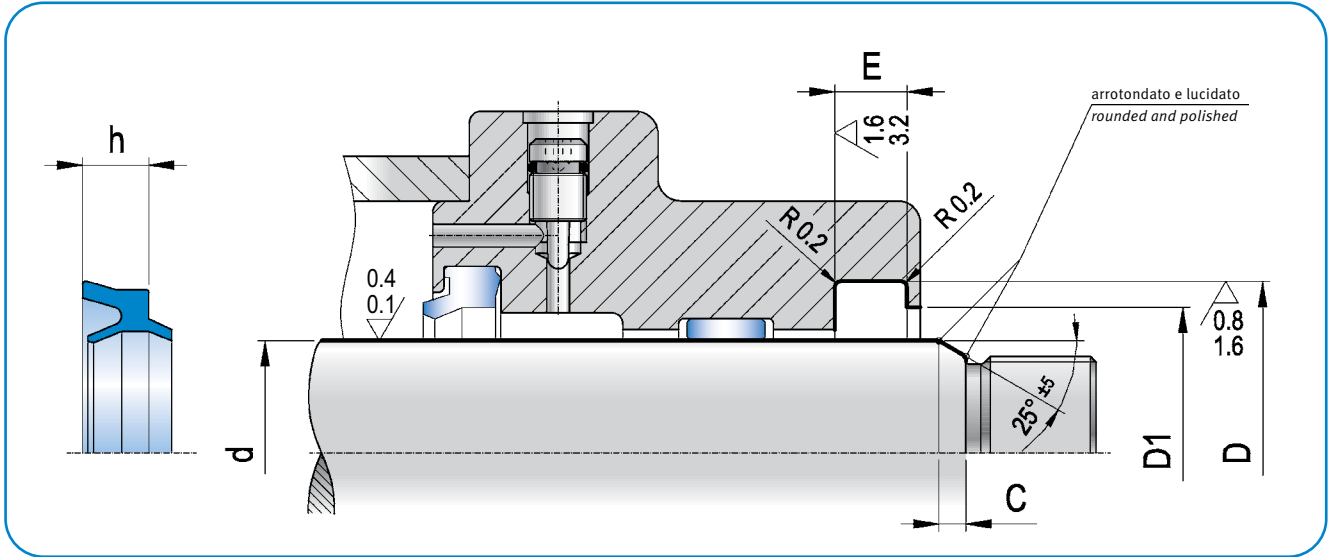
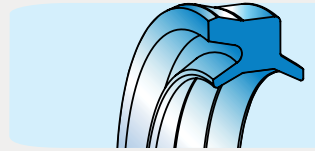

d _{f9}	D _{H10}	Toll H10	D ₁	h	E _{+0,2}	ART / ITEM
3,0	8,8	+0.058/0	5,0	4,0	4,5	BWA 0030 0088 040 Bo
4,0	7,0	+0.058/0	6,0	2,2	2,7	BWA 0040 0070 022 Bo
4,0	8,8	+0.058/0	5,4	4,0	4,5	BWA 0040 0088 040 Bo
5,0	8,0	+0.058/0	6,2	2,2	2,7	BWA 0050 0080 022 Bo
6,0	9,0	+0.070/0	7,2	2,2	2,7	BWA 0060 0090 022 Bo
6,0	10,8	+0.070/0	8,0	4,0	4,5	BWA 0060 0108 040 Bo
8,0	11,5	+0.070/0	9,2	2,5	3,0	BWA 0080 0115 025 Bo
8,0	12,8	+0.070/0	10,0	4,0	4,5	BWA 0080 0128 040 Bo
8,0	14,0	+0.070/0	11,0	4,0	4,5	BWA 0080 0140 040 Bo
10,0	14,0	+0.070/0	11,4	2,8	3,2	BWA 0100 0140 028 Bo
10,0	16,0	+0.070/0	12,5	3,6	4,0	BWA 0100 0160 036 Bo
10,0	16,8	+0.070/0	13,0	4,0	4,5	BWA 0100 0168 040 Bo
10,0	18,0	+0.070/0	14,0	4,5	5,0	BWA 0100 0180 045 Bo
12,0	16,5	+0.070/0	13,7	3,2	3,7	BWA 0120 0165 032 Bo
12,0	18,0	+0.070/0	14,5	3,6	4,0	BWA 0120 0180 036 Bo
12,0	20,0	+0.084/0	16,0	3,2	3,7	BWA 0120 0200 032 Bo
12,0	20,0	+0.084/0	16,0	4,5	5,0	BWA 0120 0200 045 Bo
12,0	20,0	+0.084/0	16,0	5,0	5,5	BWA 0120 0200 050 Bo
12,0	22,0	+0.084/0	16,0	5,0	6,0	BWA 0120 0220 050 Bo
14,0	18,5	+0.084/0	15,7	3,2	3,7	BWA 0140 0185 032 Bo
14,0	20,0	+0.084/0	16,5	3,6	4,0	BWA 0140 0200 036 Bo
14,0	22,0	+0.084/0	18,0	4,5	5,0	BWA 0140 0220 045 Bo
14,0	24,0	+0.084/0	18,0	5,0	6,0	BWA 0140 0240 050 Bo
16,0	20,5	+0.084/0	17,7	3,2	3,7	BWA 0160 0205 032 Bo
16,0	22,0	+0.084/0	18,5	3,6	4,0	BWA 0160 0220 036 Bo
16,0	24,0	+0.084/0	18,5	4,5	5,0	BWA 0160 0240 045 Bo
16,0	26,0	+0.084/0	20,0	5,0	6,0	BWA 0160 0260 050 Bo
18,0	22,5	+0.084/0	19,7	3,2	3,7	BWA 0180 0225 032 Bo
18,0	24,0	+0.084/0	20,5	3,6	4,0	BWA 0180 0240 036 Bo
18,0	26,0	+0.084/0	21,0	4,5	5,0	BWA 0180 0260 045 Bo

d _{f9}	D _{H10}	Toll H10	D ₁	h	E _{+0,2}	ART / ITEM
18,0	28,0	+0.084/0	22,0	5,0	6,0	BWA 0180 0280 050 Bo
20,0	25,0	+0.084/0	21,9	3,6	4,0	BWA 0200 0250 036 Bo
20,0	26,0	+0.084/0	22,5	3,6	4,0	BWA 0200 0260 036 Bo
20,0	30,0	+0.084/0	24,0	6,0	7,0	BWA 0200 0300 060 Bo
22,0	27,0	+0.084/0	23,9	3,6	4,0	BWA 0220 0270 036 Bo
22,0	28,0	+0.084/0	24,5	3,6	4,0	BWA 0220 0280 036 Bo
22,0	32,0	+0.084/0	26,0	6,0	7,0	BWA 0220 0320 060 Bo
25,0	30,0	+0.084/0	26,9	3,6	4,0	BWA 0250 0300 036 Bo
25,0	31,0	+0.100/0	27,5	3,6	4,0	BWA 0250 0310 036 Bo
25,0	35,0	+0.100/0	29,0	6,0	7,0	BWA 0250 0350 060 Bo
28,0	38,0	+0.100/0	32,0	6,0	7,0	BWA 0280 0380 060 Bo
30,0	35,5	+0.100/0	32,1	3,9	4,5	BWA 0300 0355 039 Bo
30,0	38,0	+0.100/0	33,0	4,5	5,0	BWA 0300 0380 045 Bo
30,0	40,0	+0.100/0	34,0	6,0	7,0	BWA 0300 0400 060 Bo
32,0	37,5	+0.100/0	34,1	3,9	4,5	BWA 0320 0375 039 Bo
32,0	40,0	+0.100/0	35,0	4,5	5,0	BWA 0320 0400 045 Bo
32,0	42,0	+0.100/0	36,0	6,0	7,0	BWA 0320 0420 060 Bo
35,0	45,0	+0.100/0	39,0	6,0	7,0	BWA 0350 0450 060 Bo
36,0	44,0	+0.100/0	39,0	4,5	5,0	BWA 0360 0440 045 Bo
36,0	46,0	+0.100/0	40,0	6,0	7,0	BWA 0360 0460 060 Bo
40,0	46,0	+0.100/0	43,0	4,3	4,8	BWA 0400 0460 043 Bo
40,0	50,0	+0.100/0	44,0	6,0	7,0	BWA 0400 0500 060 Bo
45,0	53,0	+0.120/0	48,0	4,5	5,0	BWA 0450 0530 045 Bo
45,0	55,0	+0.120/0	49,0	6,0	7,0	BWA 0450 0550 060 Bo
50,0	62,0	+0.120/0	55,0	7,5	8,5	BWA 0500 0620 075 Bo

Nota: altre dimensioni non a catalogo a richiesta. Consultare il nostro ufficio tecnico.

Remark: please contact our technical dept. for further dimensions not included in the catalogue.

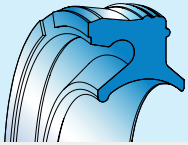

PIW

RASCHIATORE BIDIREZIONALE TIPO PIW

Descrizione

Il raschiatore bidirezionale PIW (Pneumatic Innovative bidirectional Wiper) è stato studiato per eliminare le perdite dovute a imperfezioni di lavoro nelle sedi delle testate dei cilindri pneumatici (fig.45). Testate che possono essere in materiale plastico rinforzato con fibre di vetro o in alluminio fuso lavorate a utensile. La particolare forma del profilo, con rilievi sul lato statico esterno, elimina completamente le perdite dovute a tagli, segni di lavorazione d'utensile, ovalizzazioni e conicità di sforno nelle testate in plastica.

Limiti d'impiego

Pressione: < 20 bar
 Velocità: < 1 m/s
 Temperatura: da - 40° C a + 90° C
 Fluidi: aria (lubrificata e non) grassi minerali (v. tabella 3 a p.14)

Materiale

Il materiale utilizzato è un poliuretano di durezza 90 Shore A. Codice materiale: Bo

Montaggio

Il montaggio avviene in cava chiusa. Si consiglia di eliminare spigoli vivi e bave per non danneggiare la tenuta durante la fase di montaggio.

Fig.55:

- 1- distanziali stabilizzatori per evitare back-pumping
- 2- rilievi per vincere le imperfezioni delle sedi
- 3- ampio raggio per creare effetto molla utile alle basse pressioni
- 4- raggio sul labbro dinamico per diminuire l'attrito di primo distacco
- 5- raggiatura per rendere maggiormente elastico il labbro statico

Fig.55 - Pic.55:

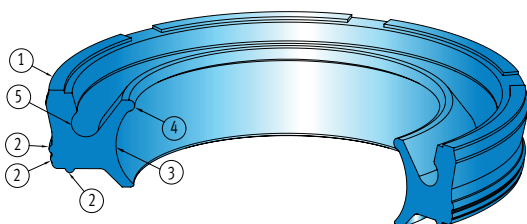

BI-DIRECTIONAL WIPER TYPE PIW

Description

The bi-directional wiper PIW "Pneumatic Innovative bidirectional Wiper" is design in order to eliminate the leakage due to the imperfection of the working in the groove of pneumatic cylinder head (Pic.45). The pneumatic head cylinder can be made in plastic material filled with glass fibers or cast aluminum machined. The particular shape of the profile, with reliefs on the external static side completely eliminates leakage due to: cut, signs of machine tool, ovality and taper draft in plastic head cylinders.

Technical data

Pressure: < 20 bar
 Speed: < 1 m/s
 Temperature: from - 40° C up to + 90° C
 Fluids: air (lubricate or not) mineral grease (see table 3, page 14)

Material

The material used is Polyurethane with hardness 90 Shore A. Material code: Bo

Assembling

The assemblin is on closed groove. Eliminate sharps and burrs to avoid damage the seal during the assembling.

Pic.55:

- 1- stabilizers spacers to avoid back-pumping
- 2- reliefs to win imperfection of the groove
- 3- big radius to create spring effect usefull at low pressure
- 4- radius on dynamic lip to decrease friction breakaway
- 5- radius to make more flexible static lip

Fig.56 - Pic.56:

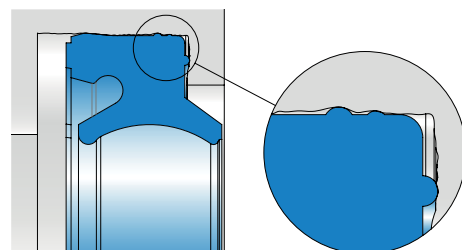



PIW

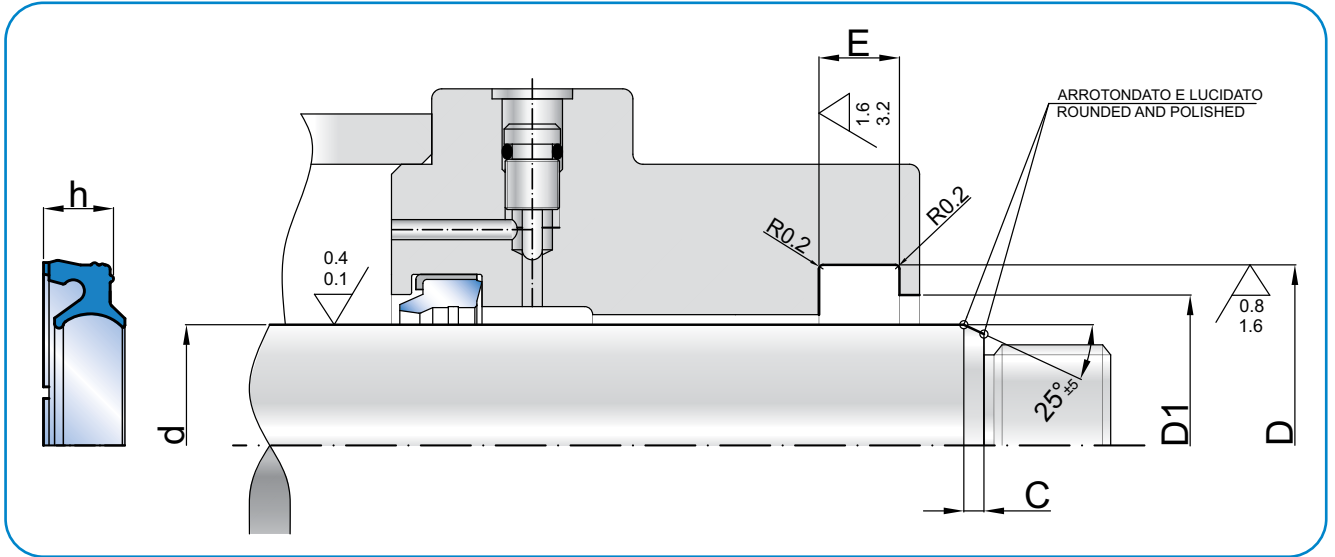
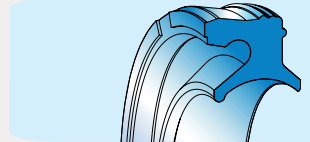

d_{f9}	D_{H10}	Toll H10	D_1	h	$E_{+0,2}$	ART / ITEM
3,0	8,8	+0.058/0	5,0	4,0	4,5	PIW 0030 0088 040 Bo
4,0	7,0	+0.058/0	6,0	2,2	2,7	PIW 0040 0070 022 Bo
4,0	8,8	+0.058/0	5,4	4,0	4,5	PIW 0040 0088 040 Bo
5,0	8,0	+0.058/0	6,2	2,2	2,7	PIW 0050 0080 022 Bo
6,0	9,0	+0.070/0	7,2	2,2	2,7	PIW 0060 0090 022 Bo
6,0	10,8	+0.070/0	8,0	4,0	4,5	PIW 0060 0108 040 Bo
8,0	11,5	+0.070/0	9,2	2,5	3,0	PIW 0080 0115 025 Bo
8,0	12,8	+0.070/0	10,0	4,0	4,5	PIW 0080 0128 040 Bo
8,0	14,0	+0.070/0	11,0	4,0	4,5	PIW 0080 0140 040 Bo
10,0	14,0	+0.070/0	11,4	2,8	3,2	PIW 0100 0140 028 Bo
10,0	16,0	+0.070/0	12,5	3,6	4,0	PIW 0100 0160 036 Bo
10,0	16,8	+0.070/0	13,0	4,0	4,5	PIW 0100 0168 040 Bo
10,0	18,0	+0.070/0	14,0	4,5	5,0	PIW 0100 0180 045 Bo
12,0	16,5	+0.070/0	13,7	3,2	3,7	PIW 0120 0165 032 Bo
12,0	18,0	+0.070/0	14,5	3,6	4,0	PIW 0120 0180 036 Bo
12,0	20,0	+0.084/0	16,0	3,2	3,7	PIW 0120 0200 032 Bo
12,0	20,0	+0.084/0	16,0	4,5	5,0	PIW 0120 0200 045 Bo
12,0	20,0	+0.084/0	16,0	5,0	5,5	PIW 0120 0200 050 Bo
12,0	22,0	+0.084/0	16,0	5,0	6,0	PIW 0120 0220 050 Bo
14,0	18,5	+0.084/0	15,7	3,2	3,7	PIW 0140 0185 032 Bo
14,0	20,0	+0.084/0	16,5	3,6	4,0	PIW 0140 0200 036 Bo
14,0	22,0	+0.084/0	18,0	4,5	5,0	PIW 0140 0220 045 Bo
14,0	24,0	+0.084/0	18,0	5,0	6,0	PIW 0140 0240 050 Bo
16,0	20,5	+0.084/0	17,7	3,2	3,7	PIW 0160 0205 032 Bo
16,0	22,0	+0.084/0	18,5	3,6	4,0	PIW 0160 0220 036 Bo
16,0	24,0	+0.084/0	18,5	4,5	5,0	PIW 0160 0240 045 Bo
16,0	26,0	+0.084/0	20,0	5,0	6,0	PIW 0160 0260 050 Bo
18,0	22,5	+0.084/0	19,7	3,2	3,7	PIW 0180 0225 032 Bo
18,0	24,0	+0.084/0	20,5	3,6	4,0	PIW 0180 0240 036 Bo
18,0	26,0	+0.084/0	21,0	4,5	5,0	PIW 0180 0260 045 Bo

d_{f9}	D_{H10}	Toll H10	D_1	h	$E_{+0,2}$	ART / ITEM
18,0	28,0	+0.084/0	22,0	5,0	6,0	PIW 0180 0280 050 Bo
20,0	25,0	+0.084/0	21,9	3,6	4,0	PIW 0200 0250 036 Bo
20,0	26,0	+0.084/0	22,5	3,6	4,0	PIW 0200 0260 036 Bo
20,0	30,0	+0.084/0	24,0	6,0	7,0	PIW 0200 0300 060 Bo
22,0	27,0	+0.084/0	23,9	3,6	4,0	PIW 0220 0270 036 Bo
22,0	29,0	+0.084/0	24,5	4,3	5,0	PIW 0220 0290 036 Bo
22,0	28,0	+0.084/0	24,5	3,6	4,0	PIW 0220 0280 036 Bo
22,0	32,0	+0.084/0	26,0	6,0	7,0	PIW 0220 0320 060 Bo
25,0	30,0	+0.084/0	26,9	3,6	4,0	PIW 0250 0300 036 Bo
25,0	31,0	+0.100/0	27,5	3,6	4,0	PIW 0250 0310 036 Bo
25,0	35,0	+0.100/0	29,0	6,0	7,0	PIW 0250 0350 060 Bo
28,0	38,0	+0.100/0	32,0	6,0	7,0	PIW 0280 0380 060 Bo
30,0	35,5	+0.100/0	32,1	3,9	4,5	PIW 0300 0355 039 Bo
30,0	38,0	+0.100/0	33,0	4,5	5,0	PIW 0300 0380 045 Bo
30,0	40,0	+0.100/0	34,0	6,0	7,0	PIW 0300 0400 060 Bo
32,0	37,5	+0.100/0	34,1	3,9	4,5	PIW 0320 0375 039 Bo
32,0	40,0	+0.100/0	35,0	4,5	5,0	PIW 0320 0400 045 Bo
32,0	42,0	+0.100/0	36,0	6,0	7,0	PIW 0320 0420 060 Bo
35,0	45,0	+0.100/0	39,0	6,0	7,0	PIW 0350 0450 060 Bo
36,0	44,0	+0.100/0	39,0	4,5	5,0	PIW 0360 0440 045 Bo
36,0	46,0	+0.100/0	40,0	6,0	7,0	PIW 0360 0460 060 Bo
40,0	46,0	+0.100/0	43,0	4,3	4,8	PIW 0400 0460 043 Bo
40,0	50,0	+0.100/0	44,0	6,0	7,0	PIW 0400 0500 060 Bo
45,0	53,0	+0.120/0	48,0	4,5	5,0	PIW 0450 0530 045 Bo
45,0	55,0	+0.120/0	49,0	6,0	7,0	PIW 0450 0550 060 Bo
50,0	62,0	+0.120/0	55,0	7,5	8,5	PIW 0500 0620 075 Bo

Nota: altre dimensioni non a catalogo a richiesta. Consultare il nostro ufficio tecnico.

Remark: please contact our technical dept. for further dimensions not included in the catalogue.

Pneumatica
Pneumatic

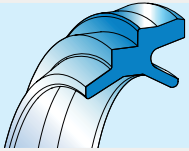

BWS

RASCHIATORE BIDIREZIONALE CON GRADINO TIPO BWS

Descrizione

Il raschiatore tipo BWS è ottenuto dalla combinazione di una guarnizione a labbri asimmetrici e un raschiatore. Sul labbro di tenuta presenta una raggiatura che lo rende molto scorrevole e sul lato statico un gradino ridotto che facilita il montaggio soprattutto per diametri piccoli. La parte raschiante ha un labbro molto sottile per non influenzare il primo distacco nel movimento del cilindro.

Limiti d'impiego

Pressione: < 20 bar
 Velocità: < 1 m/s
 Temperatura: da - 40° C a + 90° C
 Fluidi: aria con o senza lubrificazione, oli e grassi minerali (v. tabella 3 a p. 14)

Materiale

Materiale standard poliuretano a 90 Shore A.
 Codice materiale standard: Bo
 Materiale alternativo poliuretano a 85 Shore A.
 Codice materiale alternativo: Ao

Montaggio

La sede che alloggia il raschiatore deve essere priva di spigoli vivi o bave che compromettano la durata in esercizio. Per impieghi gravosi, in presenza di disallineamenti o fuori centro con diametri di stelo superiori a $\varnothing 16$ mm, è consigliato un montaggio in sede con tutta la base del raschiatore e non il semplice aggancio con il solo gradino.

BWS TYPE BI-DIRECTIONAL WIPER WITH STEP

Description

The BWS wiper combines an asymmetric lip seal profile with a wiper. On the sealing lip the BWS has a radius allowing greater smoothness and on the static side the reduced size step facilitates installation, especially for small diameters. The scraping part has a very thin lip so as not to influence the stick-slip effect in the cylinder movement.

Technical data

Pressure: < 20 bar
 Speed: < 1 m/s
 Temperature: from - 40° C up to + 90° C
 Fluids: air with or without lubrication, mineral oils or grease
 (see table 3, page 14)

Material

Standard polyurethane 90 Shore A.
 Standard compound reference: Bo
 Alternative polyurethane 85 Shore A.
 Alternative compound reference: Ao

Assembling

Remove cutting edges and/or flashes from the housing where the wiper has to be installed in order to minimise seal wear during operation.

Warning: for heavy duty applications showing misalignments or imbalance and with diameters bigger than $\varnothing 16$ mm, it's recommend to hang the base of the wiper to the housing and not only to the step.



BWS

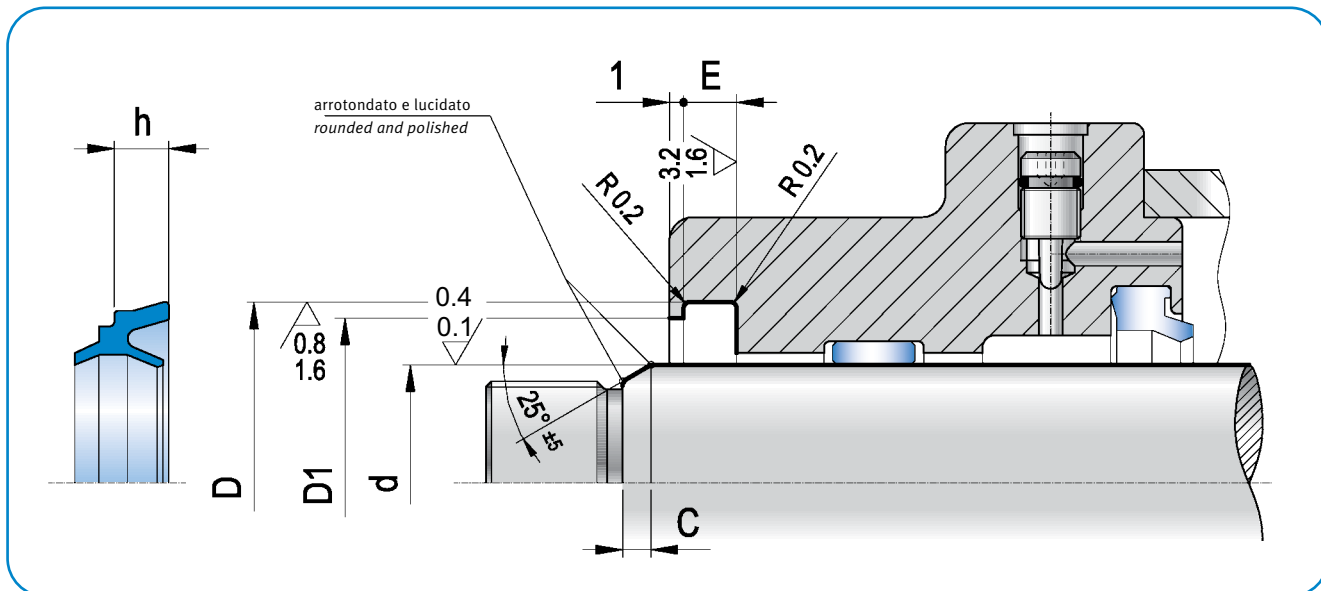
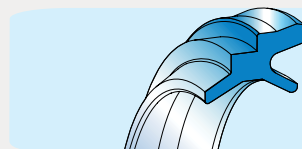

d_{f9}	D_{H10}	tol H_{10}	D_1	h	$E_{+0,2}$	ART / ITEM
4,0	8,1	+0.058/0	6,70	2,8	3,0	BWS 0040 0081 028 Bo
6,0	11,1	+0.070/0	9,10	3,3	3,6	BWS 0060 0111 033 Bo
8,0	14,1	+0.070/0	12,10	3,3	3,6	BWS 0080 0141 033 Bo
10,0	16,1	+0.070/0	14,10	3,8	4,2	BWS 0100 0161 038 Bo
12,0	18,1	+0.084/0	15,10	3,8	4,2	BWS 0120 0181 038 Bo
12,0	20,0	+0.084/0	18,00	3,6	4,0	BWS 0120 0200 036 Bo
14,0	22,0	+0.084/0	20,00	3,6	4,0	BWS 0140 0220 036 Bo
16,0	24,0	+0.084/0	22,00	3,6	4,0	BWS 0160 0240 036 Bo

Nota: altre dimensioni non a catalogo a richiesta. Consultare il nostro ufficio tecnico.

Remark: please contact our technical dept. for further dimensions not included in the catalogue.

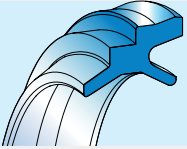

BWS

RASCHIATORE BIDIREZIONALE CON GRADINO TIPO BWS

Descrizione

Il raschiatore tipo BWS è ottenuto dalla combinazione di una guarnizione a labbri asimmetrici e un raschiatore.

Il labbro di tenuta presenta una raggiatura che lo rende molto scorrevole e il lato statico ha un gradino ridotto che ne facilita il montaggio, soprattutto per diametri piccoli. La parte raschiante ha un labbro molto sottile per non influenzare il primo distacco nel movimento del cilindro.

Limiti d'impiego

Pressione: < 20 bar

Velocità: < 1 m/s

Temperatura: da - 40° C a + 90° C

Fluidi: aria con o senza lubrificazione, oli e grassi minerali (v. tabella 3 a p. 14)

Materiale

Materiale standard poliuretano a 90 Shore A.

Codice materiale standard: Bo

Materiale alternativo poliuretano a 85 Shore A.

Codice materiale alternativo: Ao

Montaggio

La sede che alloggia il raschiatore deve essere priva di spigoli vivi o bave che compromettano la durata in esercizio. Per impieghi gravosi, in presenza di disallineamenti o fuori centro con diametri di stelo superiori a \varnothing 16 mm, è consigliato un montaggio in sede con tutta la base del raschiatore e non il semplice aggancio con il solo gradino.

BWS TYPE BI-DIRECTIONAL WIPER WITH STEP

Description

The BWS wiper combines an asymmetric lip seal profile with a wiper.

On the sealing lip the BWS has a radius allowing greater smoothness and on the static side the reduced size step facilitates installation, especially for small diameters.

The scraping part has a very thin lip so as not to influence the stick-slip effect in the cylinder movement.

Technical data

Pressure: < 20 bar

Speed: < 1 m/s

Temperature: from - 40° C up to + 90° C

Fluids: air with or without lubrication, mineral oils or grease
(see table 3, page 14)

Material

Standard polyurethane 90 Shore A.

Standard compound reference: Bo

Alternative polyurethane 85 Shore A.

Alternative compound reference: Ao

Assembling

Remove cutting edges and/or flashes from the housing where the wiper has to be installed in order to minimise seal wear during operation.

Warning: for heavy duty applications showing misalignments or imbalance and with diameters bigger than \varnothing 16 mm, it's recommend to hang the base of the wiper to the housing and not only to the step.



BWS

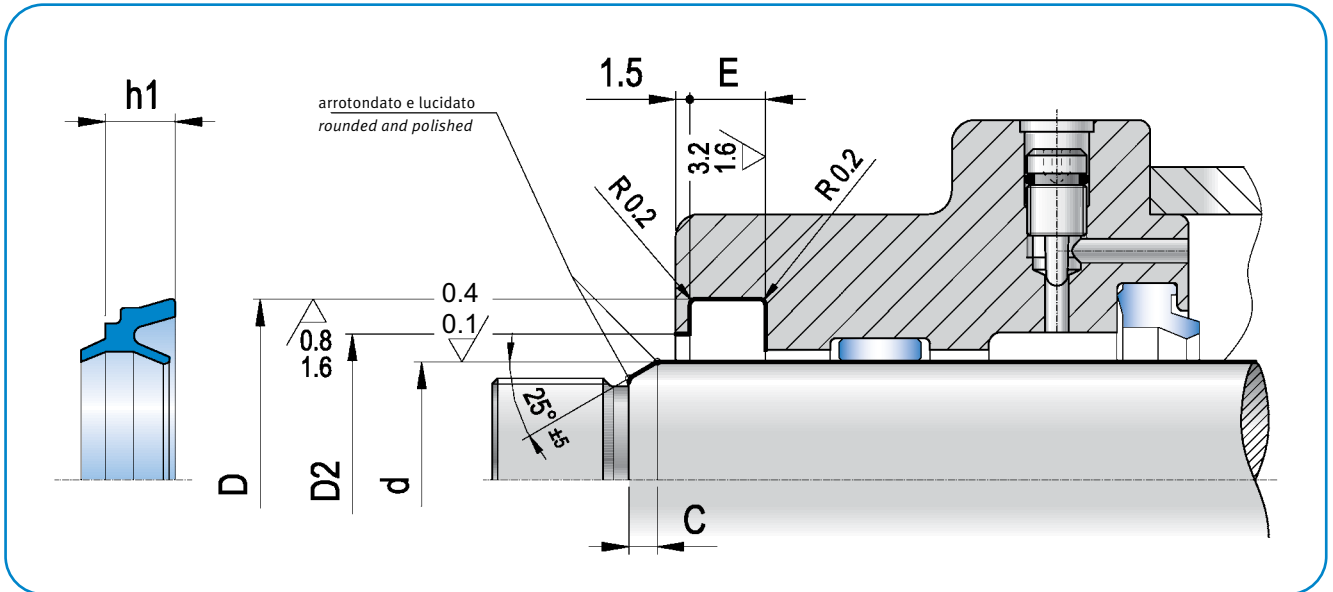
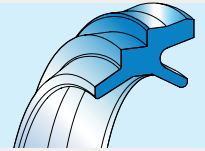

d_{f9}	D_{H10}	Toll H_{10}	D_2	h_1	$E_{+0,2}$	ART / ITEM
18	26	+0,084/0	21,5	5,6	6,0	BWS 0180 0260 056 Bo
20	28	+0,084/0	23,5	5,6	6,0	BWS 0200 0280 056 Bo
22	30	+0,084/0	25,5	5,6	6,0	BWS 0220 0300 056 Bo
25	33	+0,100/0	28,5	5,6	6,0	BWS 0250 0330 056 Bo
28	36	+0,100/0	31,5	5,6	6,0	BWS 0280 0360 056 Bo
30	38	+0,100/0	33,5	5,6	6,0	BWS 0300 0380 056 Bo
32	40	+0,100/0	35,5	5,6	6,0	BWS 0320 0400 056 Bo
35	43	+0,100/0	38,5	5,6	6,0	BWS 0350 0430 056 Bo
36	44	+0,100/0	39,5	5,6	6,0	BWS 0360 0440 056 Bo
40	46	+0,100/0	43,0	4,3	4,8	BWS 0400 0460 043 Bo
40	48	+0,100/0	43,5	5,6	6,0	BWS 0400 0480 056 Bo
42	50	+0,100/0	45,5	5,6	6,0	BWS 0420 0500 056 Bo
45	53	+0,120/0	48,5	5,6	6,0	BWS 0450 0530 056 Bo
50	58	+0,120/0	53,5	5,6	6,0	BWS 0500 0580 056 Bo
55	63	+0,120/0	58,5	5,6	6,0	BWS 0550 0630 056 Bo
56	64	+0,120/0	59,5	5,6	6,0	BWS 0560 0640 056 Bo
60	68	+0,120/0	63,5	5,6	6,0	BWS 0600 0680 056 Bo
100	108	+0,120/0	103,5	5,6	6,0	BWS 1000 1080 056 Bo

Nota: altre dimensioni non a catalogo a richiesta. Consultare il nostro ufficio tecnico.

Remark: please contact our technical dept. for further dimensions not included in the catalogue.

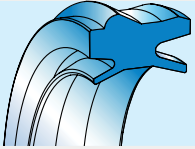

BWH

RASCHIATORE BIDIREZIONALE CON GANCIO TIPO BWH

Descrizione

La forma particolare e il profilo del raschiatore con aggancio tipo BWH e la sede completamente aperta, con una fresatura sulla parte laterale, consentono un rapido montaggio in automatico e in manuale e una sostituzione del raschiatore altrettanto facile.

Lo speciale profilo, che combina tenuta e raschiatore, è molto robusto e consente allo stelo anche significativi disallineamenti senza espulsioni dalla sede.

Inoltre, la forma dei labbri statici impedisce la penetrazione di impurità nel cilindro.

Limiti d'impiego

Pressione: < 20 bar

Velocità: < 1 m/s

Temperatura: da - 40° C a + 90° C

Fluidi: aria con o senza lubrificazione, oli e grassi minerali (v. tabella 3 a p. 14)

Materiale

Materiale standard poliuretano a 90 Shore A.

Codice materiale standard: Bo

Materiale alternativo poliuretano a 93 Shore A.

Codice materiale alternativo: Co

Montaggio

Durante il montaggio è consigliato lubrificare la parte interna del raschiatore, mentre occorre evitare di lubrificare la parte esterna e la cava per il pericolo di espulsione dalla sede.

Eliminare tutti gli spigoli vivi e le bave nella sede per facilitare il montaggio e non danneggiare la guarnizione durante l'inserimento.

BWH TYPE BI-DIRECTIONAL WIPER WITH HOOK

Description

The main characteristic of the hooked profile of the BWH wiper is to enable easy and fast installation into a complete open housing, both automatically and manually.

The groove is completely open with a lateral milling, which allows the wiper to be replaced easily.

The special profile combining seal and wiper is very strong and allows important rod misalignments without any danger of ejection from the seat.

Moreover, the static lips profile keeps the cylinder free from outside impurities.

Technical data

Pressure: < 20 bar

Speed: < 1 m/s

Temperature: from - 40° C up to + 90° C

Fluids: air with or without lubrication, mineral oils or grease
(see table 3, page 14)

Material

Standard polyurethane 90 Shore A.

Standard compound reference: Bo

Alternative polyurethane 93 Shore A.

Alternative compound reference: Co

Assembling

The wiper should be lubricated internally during installation. The external lubrication of the wiper and housing is not recommended due to the ejection risk of the wiper. It is important to remove cutting edges and flashes in the housing to prevent damages of seal during assembling.



BWH

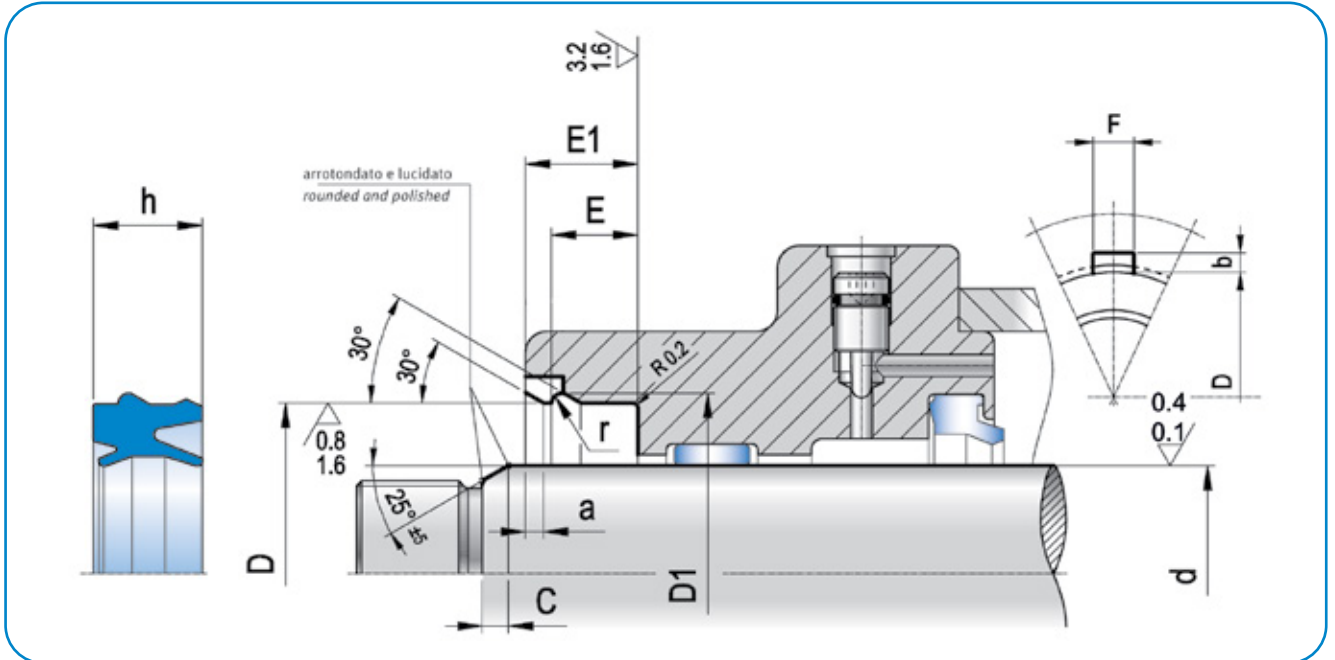
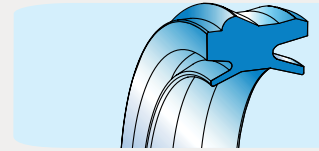

d_{f9}	D_{H10}	toll H_{10}	D_1	h	E_1	E	r	a	b	F	ART / ITEM
12,0	20,0	+0,084/0	22,0	10,7	13,0	8,8	1,1	1,5	1,8	4,0	BWH 0120 0200 107 Bo
12,0	22,0	+0,084/0	24,0	10,7	13,0	8,8	1,1	1,5	1,8	4,0	BWH 0120 0220 107 Bo
16,0	26,0	+0,084/0	28,0	10,7	13,0	8,8	1,1	1,5	1,8	5,0	BWH 0160 0260 107 Bo
18,0	26,0	+0,084/0	28,0	10,7	13,0	8,8	1,1	1,5	1,8	5,0	BWH 0180 0260 107 Bo
18,0	28,0	+0,084/0	30,0	10,7	13,0	8,8	1,1	1,5	1,8	5,0	BWH 0180 0280 107 Bo
20,0	30,0	+0,084/0	32,0	10,7	13,0	8,8	1,1	1,5	1,8	5,0	BWH 0200 0300 107 Bo
22,0	32,0	+0,100/0	34,5	11,2	14,0	9,4	1,4	2,0	2,0	7,5	BWH 0220 0320 112 Bo
25,0	35,0	+0,100/0	37,5	11,2	14,0	9,4	1,4	2,0	2,0	7,5	BWH 0250 0350 112 Bo
30,0	40,0	+0,100/0	42,5	11,2	14,0	9,4	1,4	2,0	2,0	7,5	BWH 0300 0400 112 Bo
32,0	42,0	+0,100/0	44,5	11,2	14,0	9,4	1,4	2,0	2,0	7,5	BWH 0320 0420 112 Bo
40,0	50,0	+0,100/0	52,5	11,2	14,0	9,4	1,4	2,0	2,0	7,5	BWH 0400 0500 112 Bo
45,0	55,0	+0,120/0	58,2	12,2	15,0	10,4	1,8	2,0	2,5	10,0	BWH 0450 0550 122 Bo
50,0	60,0	+0,120/0	63,2	12,2	15,0	10,4	1,8	2,0	2,5	10,0	BWH 0500 0600 122 Bo
63,0	75,0	+0,120/0	78,2	13,0	16,0	11,4	1,8	2,0	2,5	10,0	BWH 0630 0750 130 Bo

Nota: altre dimensioni non a catalogo a richiesta. Consultare il nostro ufficio tecnico.

Remark: please contact our technical dept. for further dimensions not included in the catalogue.

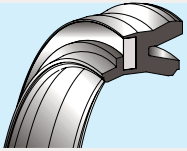

BWH/N

RASCHIATORE BIDIREZIONALE CON GANCIO TIPO BWH/N

Descrizione

La particolare geometria del raschiatore BWH/N, senza aggancio e con anima metallica vulcanizzata all'interno, per sede completamente aperta, favorisce il montaggio in automatico. Il bassorilievo creato in sede, porta seeger, garantisce la non espulsione del raschiatore. Estremamente semplice anche la sostituzione in caso di manutenzione. Lo speciale profilo, che combina la tenuta e il raschiatore in un'unica soluzione, impedisce la penetrazione di impurità nel cilindro.

Limiti d'impiego

Pressione: < 16 [bar]
 Velocità: < 1 [m/s]
 Temperatura: da -30°C a +100°C per la versione in NBR
 da -15°C a +200°C per la versione in FKM
 Fluidi: aria lubrificata, grassi e oli minerali (v. tabella 3 a p. 14)

Materiale

Il materiale standard è NBR 75 Shore A colore nero. In alternativa FKM 75 Shore A di colore marrone.
 Codice materiale standard: NG

Montaggio

Per il montaggio: inserire il raschiatore e posizionare il seeger nell'apposita nicchia. Si consiglia di lubrificare la sede e togliere gli spigoli vivi creati da lavorazione meccanica.

BWH/N TYPE BI-DIRECTIONAL WIPER WITH HOOK

Description

The special geometry of the wiper BWH/N, without hanging, with vulcanized metal core inside, for completely open groove, improve the assembling. The grooved seat circlip holder, avoids the scraper ejection. The replacement is also very simple during maintenance. The special profile combining seal and wiper in a single solution, keeps the cylinder free from outside impurities.

Technical data

Pressure: < 16 [bar]
 Speed: < 1 [m/s]
 Temperature: from -30°C to +100°C for NBR version
 from -15°C to +200°C for FKM version
 Fluids: lubricated air, grease and mineral oils (see table 3, page 14)

Material

Standard material is NBR 75 Shore A black colour. In alternative FKM 75 Shore A brown colour.
 Compound reference: NG

Assembling

We suggest assembling as follows:

- insert scraper
- place circlip in the niche.

It is recommended to lubricate the seat and remove the sharp edges originated by the machining.



BWH / N

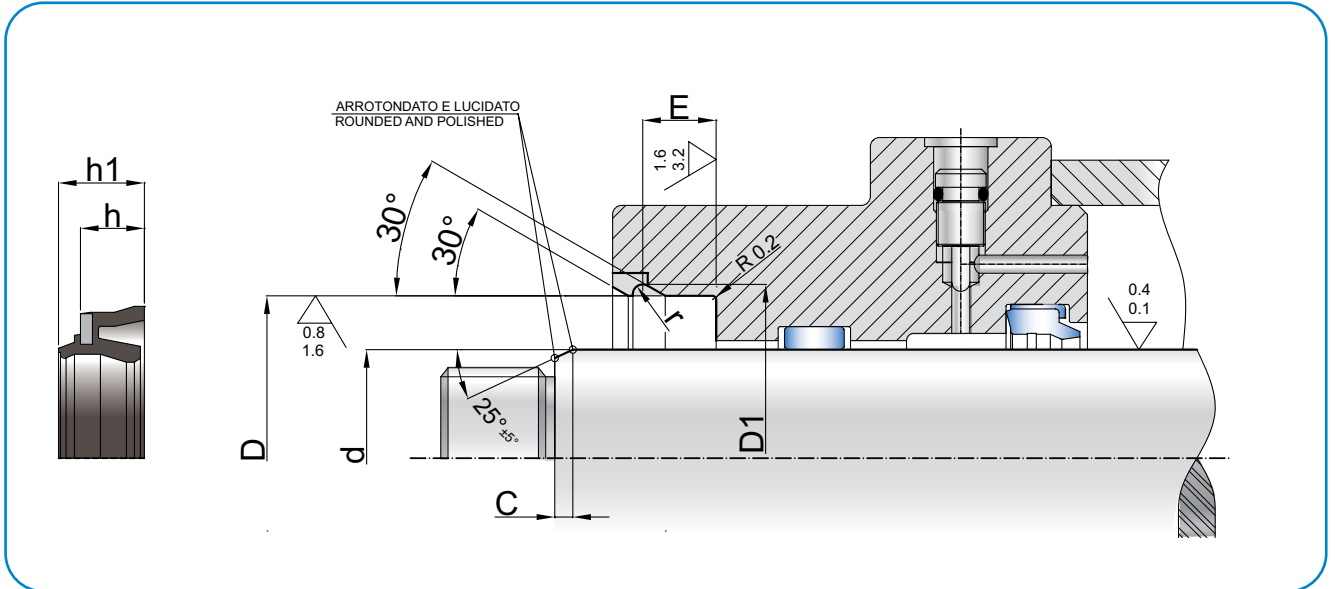
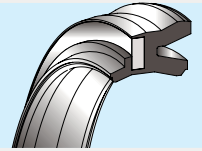

df9	DH10	h	h ₁	D ₁	E	r	ART / ITEM
10,0	20,0	7,0	9,5	22,00	8,50	1,10	BWH 0100 0200 070 NG
12,0	20,0	6,0	8,5	22,00	7,50	1,10	BWH 0120 0200 060 NG
12,0	22,0	7,0	9,5	24,00	8,50	1,10	BWH 0120 0220 070 NG
14,0	24,0	7,0	9,5	26,00	8,50	1,10	BWH 0140 0240 070 NG
16,0	26,0	7,0	9,5	28,00	8,50	1,10	BWH 0160 0260 070 NG
18,0	26,0	6,0	8,5	28,00	7,50	1,10	BWH 0180 0260 060 NG
18,0	28,0	7,0	9,5	30,00	8,50	1,10	BWH 0180 0280 070 NG
20,0	30,0	7,0	9,5	32,00	8,50	1,10	BWH 0200 0300 070 NG
22,0	32,0	7,0	9,5	34,50	8,80	1,40	BWH 0220 0320 070 NG
25,0	35,0	7,0	9,5	37,50	8,80	1,40	BWH 0250 0350 070 NG
30,0	40,0	7,0	9,5	42,50	8,80	1,40	BWH 0300 0400 070 NG
32,0	42,0	7,0	9,5	44,50	8,80	1,40	BWH 0320 0420 070 NG
40,0	50,0	7,0	9,5	52,50	8,80	1,40	BWH 0400 0500 070 NG
50,0	60,0	7,0	9,0	62,50	8,30	1,40	BWH 0500 0600 070 NG

Nota: altre dimensioni non a catalogo a richiesta. Consultare il nostro ufficio tecnico.

Remark: please contact our technical dept. for further dimensions not included in the catalogue.



CUP

MEMBRANE PER SCARICO RAPIDO TIPO CUP

Descrizione

Le membrane per scarico rapido tipo CUP sono utilizzate sulle valvole per aumentare la velocità di traslazione nei cilindri a semplice e doppio effetto e per depressurizzare velocemente nel caso di svuotamento di serbatoi o altro.

Limiti d'impiego

Pressione: da 0,5 a 10 [bar]

Temperatura: da -40°C a +90°C

Fluidi: aria secca o lubrificata (se lubrificata si consiglia olio ISO VG32).

Materiale

Materiale standard poliuretano a 90 Shore A.

Codice materiale standard: Bo

Per impieghi superiori a 90°C il materiale utilizzato è poliuretano per alte temperature (135°C)

Codice materiale standard: Go

Montaggio

Il montaggio avviene in sede aperta.

CUP TYPE MEMBRANES FOR QUICK EXHAUST VALVES

Description

The membranes for quick exhaust valves are used on CUP type for faster travel speed, in single and double acting cylinder, and to depressurize quickly if you want to empty the tanks or otherwise.

Technical data

Pressure: from 0,5 to 10 [bar]

Temperature: from -40°C to +90°C

Fluids: dry or lubricated air (in case of lubricated is recommended to use oil ISO VG32).

Material

Standard polyurethane 90 Shore A.

Standard compound reference: Bo

for applications above 90°C, the material used is polyurethane for high temperatures (135°C)

Code standard material: Go

Assembling

The assembly is in open groove.

It is recommended to lubricate with mineral grease.



CUP

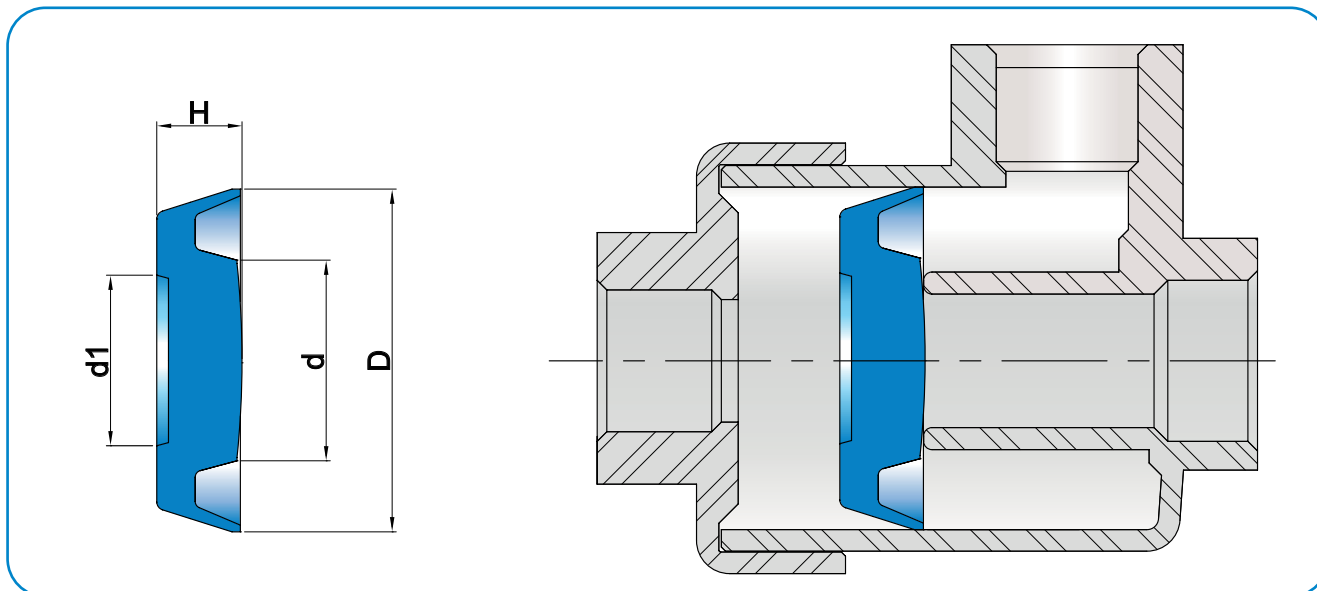

Rif.	D+0,5	H+0,3	d	d1	ART / ITEM
12	12,4	4,0	5,5	2	CUP 0120 Bo
1/8"	20,5	5,0	11,0	10,0	CUP 0200 Bo
1/4"-3/8"	25,6	5,5	15,0	10,0	CUP 0250 Bo
1/2"	35,8	7,9	20,0	14,0	CUP 0350 Bo
3/4"-1"	41,0	7,9	27,0	17,0	CUP 0400 Bo

Nota: altre dimensioni non a catalogo a richiesta. Consultare il nostro ufficio tecnico.

Remark: please contact our technical dept. for further dimensions not included in the catalogue.

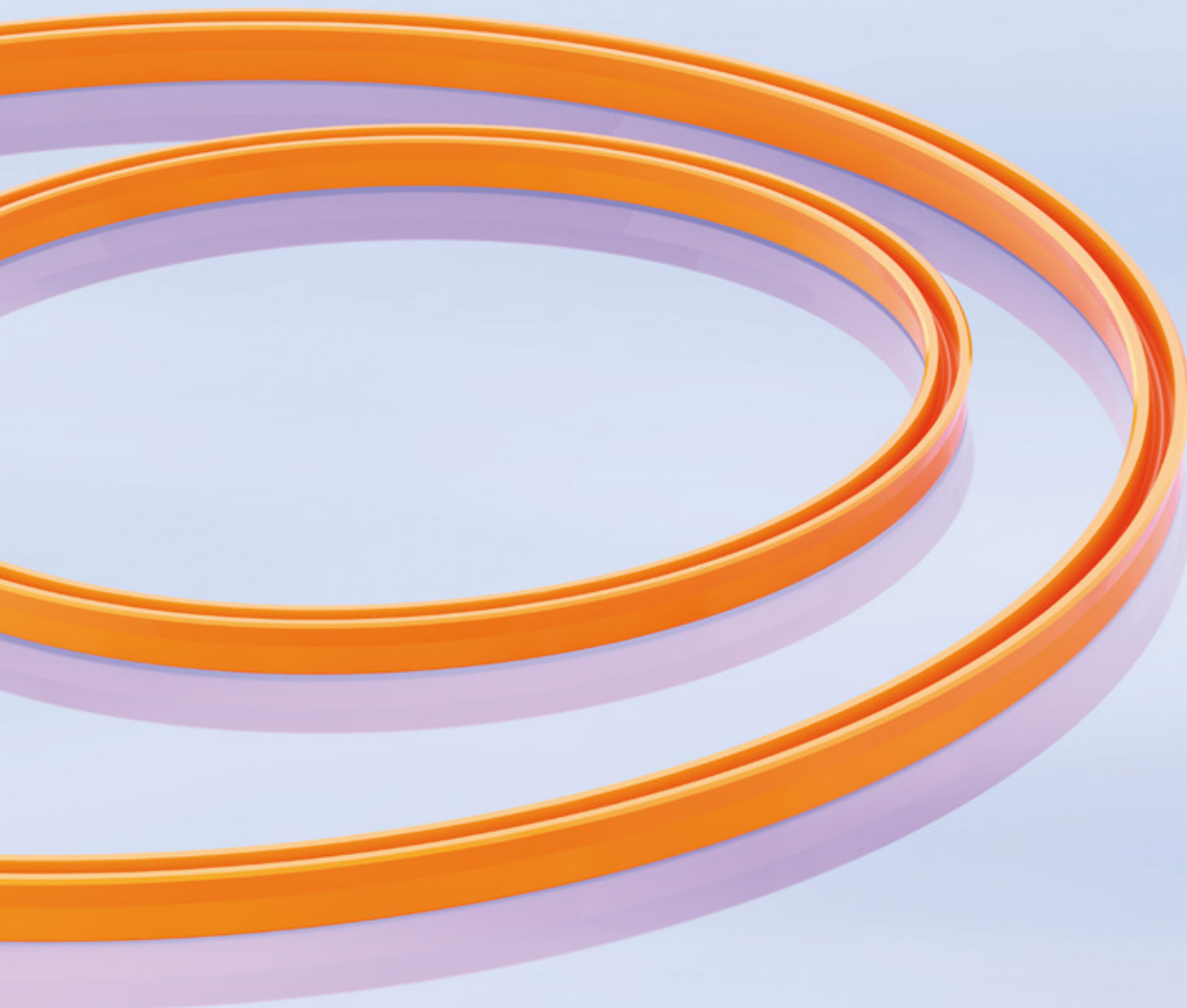



Poliuretano colato

Cast polyurethane



Poliuretano colato

Cast polyurethane

Descrizione

Lo stampaggio per colata utilizza resine poliuretane liquide bicomponenti, molto fluide, formate da un componente chiamato Poliolo ed uno chiamato Isocianato che funge da catalizzatore. Miscelati in un rapporto stechiometrico danno origine ad un prodotto compatto ma allo stesso tempo molto flessibile.

Nel caso specifico delle guarnizioni, i componenti utilizzati possono essere a base polietere o poliestere, e in vari metodi quali MDI, TODI o PPDI. Le guarnizioni stampate con il metodo a colata hanno una elevata elasticità, una elevata resistenza alle pressioni e un'ottima resistenza all'abrasione. I motivi che inducono ad utilizzare questo metodo sono molteplici:

- Ridurre i costi rispetto a stampi tradizionali a iniezione.
- Possibilità di eseguire diametri molto grandi
- Possibilità di eseguire forme complesse e con sottosquadri

Description

Cast molding uses two-component liquid polyurethane resins, very fluid, formed by a component called Polyol and one called Isocyanate which acts as a catalyst.

Mixed in a stoichiometric ratio they generate a compact but at the same time very flexible product. In the specific case of seals, the components used can be polyether or polyester based, and in various methods such as MDI, TODI or PPDI.



The seals molded with the cast method have a high elasticity, a high resistance to pressure and an excellent resistance to abrasion.

The reasons for using this method are many:

- Reduce costs compared to traditional injection molds.
- Possibility to execute very big diameters
- Possibility to perform complex shapes with undercuts



Profili Profile

GUARNIZIONI IN POLIURETANO COLATO / CAST POLYURETHANE SEALS										
Condizioni massime non simultanee / Maximum conditions (not combined)										
Profilo Profile	Ns Rif. Our Ref.	Temperatura Temperature C°	Pressione Pressure Bar	Velocità Speed m/s	Materiale Material	TPU POM / PA PTFE Bronze	NBR	TPE Resina PTFE Carbo. PTFE	Sezione Section	Pagina Page
	MAD-UMAD	-35 +100	< 400	-	TPU	●			Colata Cast	332
	CSC	-35 +100	< 400	-	TPU	●			Colata Cast	336
	RAD	-35 +100	< 500	-	TPU	●			Colata Cast	339

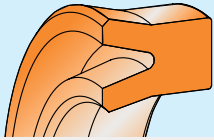

MAD - UMAD

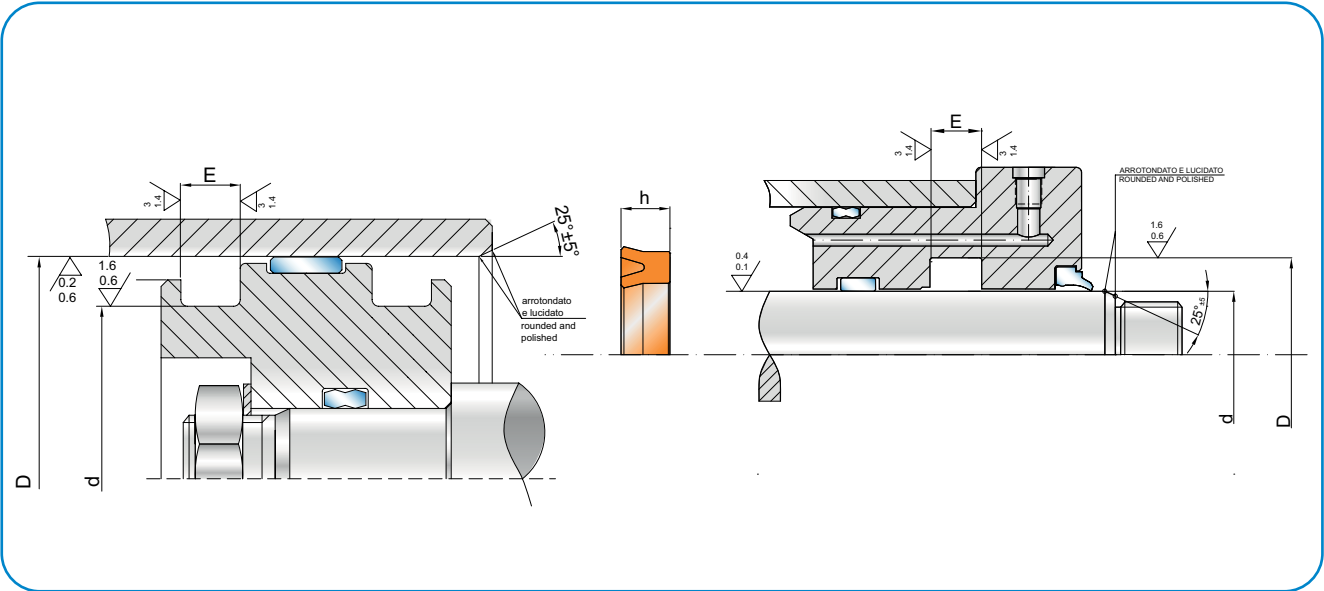

dh9	DH10	H	E+0,2	ART / ITEM
250	270	15	16	MAD 270250
250	275	12	13	UMAD 275250
250	275	18,5	20	MAD 275250
250	280	22	24	MAD 280250
250	290	20	22	UMAD 290250
255	270	11	12	MAD 270255
255	280	12	13	UMAD 280255
255	280	18,5	20	MAD 280255
260	275	11	12	MAD 275260
260	280	15	16	MAD 280260
260	285	12	13	UMAD 285260
260	285	18,5	20	MAD 285260
260	290	22	24	MAD 290260
260	300	20	22	UMAD 300260
265	280	11	12	MAD 280265
265	290	12	13	UMAD 290265
265	290	18,5	20	MAD 290265
270	285	11	12	MAD 285270
270	290	15	16	MAD 290270
270	295	12	13	UMAD 295270
270	295	18,5	20	MAD 295270
270	300	15	16	MAD 300270/1
270	300	22	24	MAD 300270
270	310	20	22	UMAD 310270
275	290	11	12	MAD 290275
275	300	12	13	UMAD 300275
275	300	18,5	20	MAD 300275

dh9	DH10	H	E+0,2	ART / ITEM
280	295	11	12	MAD 295280
280	300	15	16	MAD 300280
280	305	12	13	UMAD 305280
280	305	18,5	20	MAD 305280
280	310	22	24	MAD 310280
280	320	20	22	UMAD 320280
285	300	11	12	MAD 300285
285	310	12	13	UMAD 310285
290	305	11	12	MAD 305290
290	310	15	16	MAD 310290
290	315	12	13	UMAD 315290
290	315	18,5	20	MAD 315290
290	320	22	24	MAD 320290
290	330	20	22	UMAD 330290
295	310	11	12	MAD 310295
295	320	12	13	UMAD 320295
295	320	18,5	20	MAD 320295
300	315	11	12	MAD 315300
300	320	15	16	MAD 320300
300	325	12	13	UMAD 325300
300	325	18,5	20	MAD 325300
300	330	22	24	MAD 330300
300	340	20	22	UMAD 340300
305	320	11	12	MAD 320305
305	330	12	13	UMAD 330305
310	330	15	16	MAD 330310
310	335	12	13	UMAD335310



MAD - UMAD

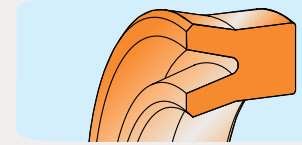

d _{H9}	D _{H10}	H	E _{+0,2}	ART / ITEM
310	335	18,5	20	MAD 335310
310	340	22	24	MAD 340310
310	350	20	22	UMAD 350310
315	330	11	12	MAD 330315
315	340	12	13	UMAD 340315
315	340	18,5	20	MAD 340315
320	335	11	12	MAD 335320
320	340	15	16	MAD 340320
320	345	12	13	UMAD 345320
320	345	18,5	20	MAD 345320
320	350	22	24	MAD 350320
320	360	20	22	UMAD 360320
325	340	11	12	MAD 340325
325	350	12	13	UMAD 350325
325	350	18,5	20	MAD 350325
330	345	11	12	MAD 345330
330	350	15	16	MAD 350330
330	355	12	13	UMAD 355330
330	355	18,5	20	MAD 355330
330	360	22	24	MAD 360330
330	370	20	22	UMAD 370330
335	350	11	12	MAD 350335
335	360	12	13	UMAD 360335
340	355	11	12	MAD 355340
340	360	15	16	MAD 360340
340	365	12	13	UMAD 365340
340	365	18,5	20	MAD 365340
340	370	22	24	MAD 370340
340	380	20	22	UMAD 380340
345	360	11	12	MAD 360345
345	370	12	13	UMAD 370345
345	370	18,5	20	MAD 370345
350	365	11	12	MAD 365350
350	370	15	16	MAD 370350
350	375	12	13	UMAD 375350
350	375	18,5	20	MAD 375350
350	380	22	24	MAD 380350
350	390	20	22	UMAD 390350
355	370	11	12	MAD 370355
355	380	12	13	UMAD 380355
360	375	11	12	MAD 375360
360	380	15	16	MAD 380360
360	385	12	13	UMAD 385360
360	390	22	24	MAD 390360
360	400	20	22	UMAD 400360

d _{H9}	D _{H10}	H	E _{+0,2}	ART / ITEM
365	380	11	12	MAD 380365
365	390	12	13	UMAD 390365
365	390	18,5	20	MAD 390365
370	390	15	16	MAD 390370
370	395	12	13	UMAD 395370
370	400	22	24	MAD 400370
370	410	20	22	UMAD 410370
375	400	12	13	UMAD 400375
380	400	15	16	MAD 400380
380	405	12	13	UMAD 405380
380	410	22	24	MAD 410380
380	420	20	22	UMAD 420380
385	410	12	13	UMAD 410385
385	410	18,5	20	MAD 410385
390	410	15	16	MAD 410390
390	415	12	13	UMAD 415390
390	415	18,5	20	MAD 415390
390	430	20	22	UMAD 430390
395	420	12	13	UMAD 420395
395	420	18,5	20	MAD 420395
400	420	15	16	MAD 420400
400	425	12	13	UMAD 425400
400	425	18,5	20	MAD 425400
400	430	22	24	MAD 430400
400	440	20	22	UMAD 440400
405	430	12	13	UMAD 430405
410	430	15	16	MAD 430410
410	435	12	13	UMAD 435410
410	440	22	24	MAD 440410
410	450	20	22	UMAD 450410
415	440	12	13	UMAD 440415
420	440	15	16	MAD 440420
420	445	12	13	UMAD 445420
420	450	22	24	MAD 450420
420	460	20	22	UMAD 460420
425	450	12	13	UMAD 450425
425	450	18,5	20	MAD 450425
430	450	15	16	MAD 450430
430	455	12	13	UMAD 455430
430	455	18,5	20	MAD 455430
430	460	22	24	MAD 460430
430	470	20	22	UMAD 470430
435	460	12	13	UMAD 460435
440	460	15	16	MAD 460440
440	465	12	13	UMAD 465440

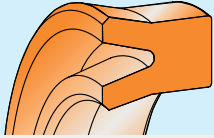

MAD - UMAD

d _{h9}	D _{H10}	H	E _{+0,2}	ART / ITEM
440	465	18,5	20	MAD 465440
440	480	20	22	UMAD 480440
450	470	15	16	MAD 470450
450	480	22	24	MAD 480450
450	490	20	22	UMAD 490450
460	480	15	16	MAD 480460
460	490	22	24	MAD 490460
460	500	20	22	UMAD 500460
470	490	15	16	MAD 490470
470	500	22	24	MAD 500470
470	510	20	22	UMAD 510470
480	500	15	16	MAD 500480
480	510	22	24	MAD 510480
480	520	20	22	UMAD 520480
490	510	15	16	MAD 510490
490	520	22	24	MAD 520490
490	530	20	22	UMAD 530490
500	520	15	16	MAD 520500
500	530	22	24	MAD 530500
500	540	20	22	UMAD 540500
510	530	15	16	MAD 530510
510	540	22	24	MAD 540510
510	550	20	22	UMAD 550510
520	540	15	16	MAD 540520
520	550	22	24	MAD 550520
520	560	20	22	UMAD 560520
530	550	15	16	MAD 550530

d _{h9}	D _{H10}	H	E _{+0,2}	ART / ITEM
530	560	22	24	MAD 560530
530	570	20	22	UMAD 570530
540	560	15	16	MAD 560540
540	580	20	22	UMAD 580540
550	570	15	16	MAD 570550
550	590	20	22	UMAD 590550
560	580	15	16	MAD 580560
560	590	22	24	MAD 590560
560	600	20	22	UMAD 600560
570	590	15	16	MAD 590570
570	610	20	22	UMAD 610570
580	600	15	16	MAD 600580
580	610	22	24	MAD 610580
590	620	22	24	MAD 620590
600	620	15	16	MAD 620600
600	630	22	24	MAD 630600
610	640	22	24	MAD 640610
630	660	22	24	MAD 660630
640	670	22	24	MAD 670640
650	680	22	24	MAD 680650
670	700	22	24	MAD 700670
680	710	22	24	MAD 710680
690	720	22	24	MAD 720690
700	730	22	24	MAD 730700
710	740	22	24	MAD 740710
720	750	22	24	MAD 750720



MAD - UMAD

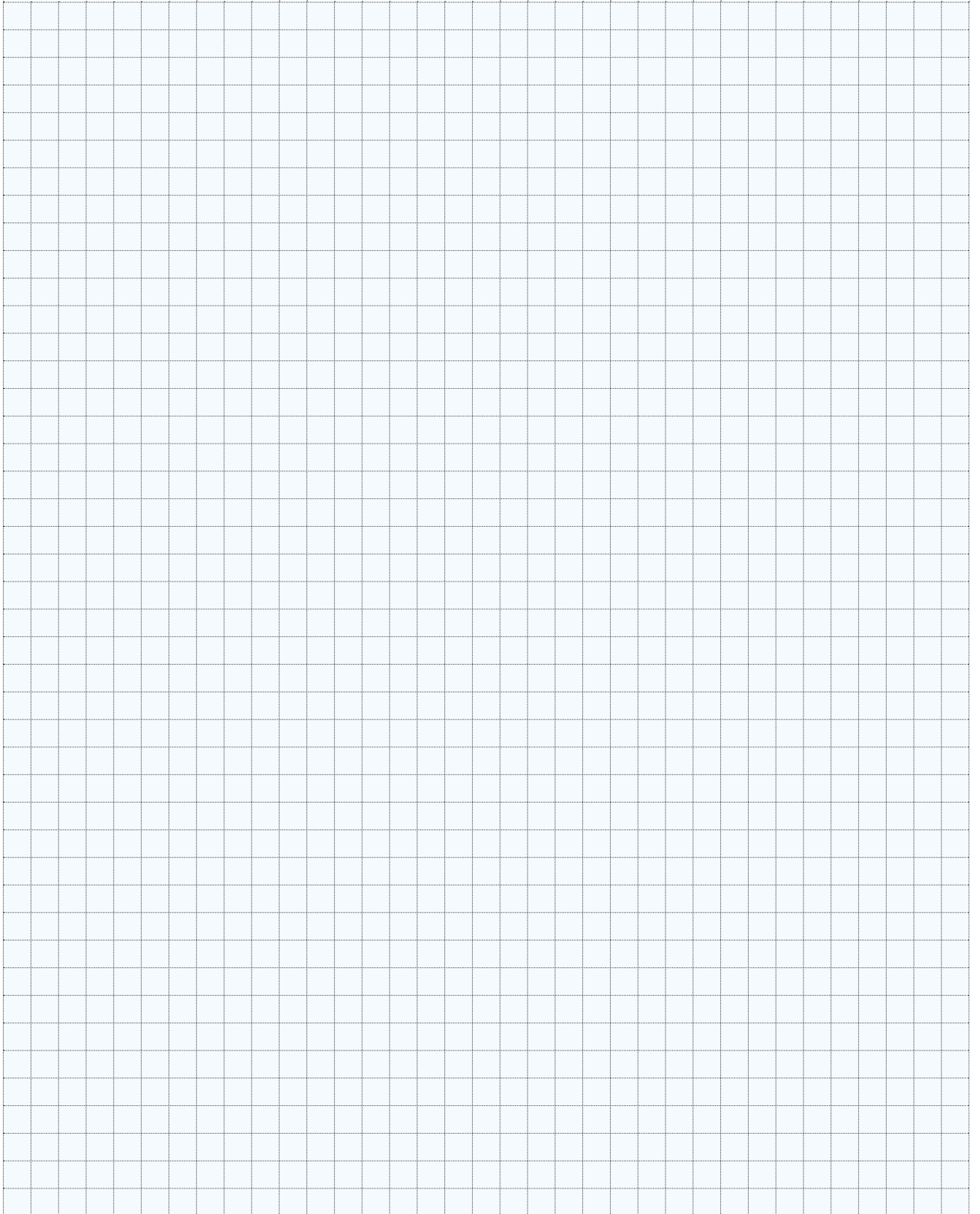
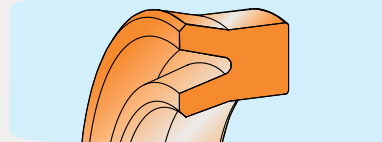

Poliuretano colato
Cast polyurethane

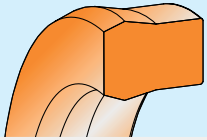

CSC

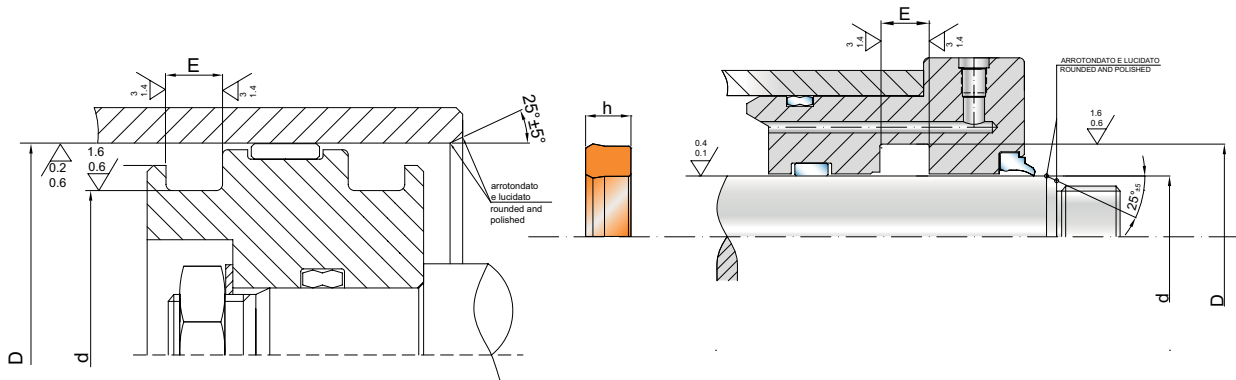

d _{h9}	D _{H10}	H	E _{+0,2}	ART / ITEM
250	265	11	12	CSC 265250
250	270	15	16	CSC 270250
250	275	18,5	20	CSC 275250
250	280	22	24	CSC 280250
250	290	22	24	CSC 290250/1
255	270	11	12	CSC 270255
255	280	18,5	20	CSC 280255
260	270	7,5	8	CSC 270260
260	275	11	12	CSC 275260
260	280	15	16	CSC 280260
260	285	18,5	20	CSC 285260
260	290	22	24	CSC 290260
265	280	11	12	CSC 280265
265	290	18,5	20	CSC 290265
266,7	298,4	24	26	CSC 29840/1
270	280	7,5	8	CSC 280270
270	282	7	7,5	CSC 282270/1
270	285	11	12	CSC 285270
270	290	15	16	CSC 290270
270	295	18,5	20	CSC 295270
270	300	22	24	CSC 300270
272,1	292,1	15	16	CSC 29210/2
275	290	11	12	CSC 290275
275	300	18,5	20	CSC 300275
280	290	7,5	8	CSC 290280
280	295	11	12	CSC 295280
280	300	15	16	CSC 300280

d _{h9}	D _{H10}	H	E _{+0,2}	ART / ITEM
280	305	18,5	20	CSC 305280
280	310	22	24	CSC 310280
285	300	11	12	CSC 300285
285	310	18,5	20	CSC 310285
290	300	7,5	8	CSC 300290
290	305	11	12	CSC 305290
290	310	15	16	CSC 310290
290	315	18,5	20	CSC 315290
290	320	22	24	CSC 320290
292,1	323,8	25,4	27,5	CSC 32380/1
295	310	11	12	CSC 310295
295	320	18,5	20	CSC 320295
298,4	330,2	25,4	27,5	CSC 33020/1
300	310	7,5	8	CSC 310300
300	315	11	12	CSC 315300
300	320	15	16	CSC 320300
300	325	18,5	20	CSC 325300
300	330	22	24	CSC 330300
304,8	330,2	25,4	27,5	CSC 33020/2
304,8	336,5	25,4	27,5	CSC 33650/1
305	320	11	12	CSC 320305
305	330	18,5	20	CSC 330305
310	320	7,5	8	CSC 320310
310	325	11	12	CSC 325310
310	330	15	16	CSC 330310
310	335	18,5	20	CSC 335310
310	340	22	24	CSC 340310



CSC

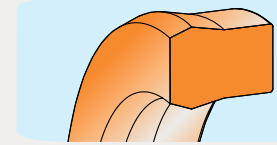

d _{h9}	D _{H10}	H	E _{+0,2}	ART / ITEM
315	325	7,5	8	CSC 325315
315	330	11	12	CSC 330315
315	340	18,5	20	CSC 340315
320	330	7,5	8	CSC 330320
320	335	11	12	CSC 335320
320	340	15	16	CSC 340320
320	345	18,5	20	CSC 345320
320	350	22	24	CSC 350320
320	360	24	26	CSC 360320/1
325	340	11	12	CSC 340325
325	350	18,5	20	CSC 350325
330	340	7,5	8	CSC 340330
330	345	11	12	CSC 345330
330	350	15	16	CSC 350330
330	355	18,5	20	CSC 355330
330	360	22	24	CSC 360330
335	350	11	12	CSC 350335
335	360	18,5	20	CSC 360335
340	350	7,5	8	CSC 350340
340	355	11	12	CSC 355340
340	360	15	16	CSC 360340
340	365	18,5	20	CSC 365340
340	370	22	24	CSC 370340
345	355	7,5	8	CSC 355345
345	360	11	12	CSC 360345
345	370	18,5	20	CSC 370345
350	360	7,5	8	CSC 360350
350	365	11	12	CSC 365350
350	370	15	16	CSC 370350
350	375	18,5	20	CSC 375350
350	380	22	24	CSC 380350
350	385	23,5	25,5	CSC 38350/1
354	381	20	22	CSC 381354/1
355	370	11	12	CSC 370355
355	380	18,5	20	CSC 380355
360	370	7,5	8	CSC 370360
360	375	11	12	CSC 375360
360	380	15	16	CSC 380360
360	385	18,5	20	CSC 385360
360	390	22	24	CSC 390360
365	380	11	12	CSC 380365
365	390	18,5	20	CSC 390365
370	380	7,5	8	CSC 380370
370	390	15	16	CSC 390370
370	395	18,5	20	CSC 395370

d _{h9}	D _{H10}	H	E _{+0,2}	ART / ITEM
370	400	22	24	CSC 400370
375	400	18,5	20	CSC 400375
380	390	7,5	8	CSC 390380
380	400	15	16	CSC 400380
380	405	18,5	20	CSC 405380
380	410	22	24	CSC 410380
385	410	18,5	20	CSC 410385
390	400	7,5	8	CSC 400390
390	410	15	16	CSC 410390
390	415	18,5	20	CSC 415390
390	420	22	24	CSC 420390
395	420	18,5	20	CSC 420395
400	410	7,5	8	CSC 410400
400	420	15	16	CSC 420400
400	425	18,5	20	CSC 425400
400	430	22	24	CSC 430400
405	430	18,5	20	CSC 430405
410	420	7,5	8	CSC 420410
410	430	15	16	CSC 430410
410	435	18,5	20	CSC 435410
410	440	22	24	CSC 440410
415	440	18,5	20	CSC 440415
419,1	450,8	25,4	27,5	CSC 45080/1
420	430	7,5	8	CSC 430420
420	440	15	16	CSC 440420
420	445	18,5	20	CSC 445420
420	450	22	24	CSC 450420
425	450	18,5	20	CSC 450425
430	440	7,5	8	CSC 440430
430	450	15	16	CSC 450430
430	455	18,5	20	CSC 455430
430	460	22	24	CSC 460430
435	460	18,5	20	CSC 460435
440	450	7,5	8	CSC 450440
440	460	15	16	CSC 460440
440	465	18,5	20	CSC 465440
440	470	22	24	CSC 470440
450	460	7,5	8	CSC 460450
450	470	15	16	CSC 470450
450	480	22	24	CSC 480450
460	470	7,5	8	CSC 470460
460	480	15	16	CSC 480460
460	490	22	24	CSC 490460
470	480	7,5	8	CSC 480470
470	490	15	16	CSC 490470

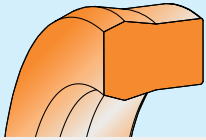

CSC

d _{H9}	D _{H10}	H	E _{+0,2}	ART / ITEM
470	500	22	24	CSC 500470
480	490	7,5	8	CSC 490480
480	500	15	16	CSC 500480
480	510	22	24	CSC 510480
490	500	7,5	8	CSC 500490
490	510	15	16	CSC 510490
490	520	22	24	CSC 520490
500	520	15	16	CSC 520500
500	530	22	24	CSC 530500
510	530	15	16	CSC 530510
510	540	22	24	CSC 540510
520	540	15	16	CSC 540520
520	550	22	24	CSC 550520
530	550	15	16	CSC 550530
530	560	22	24	CSC 560530
535	545	7,5	8	CSC 545535
540	560	15	16	CSC 560540
540	570	22	24	CSC 570540
550	570	15	16	CSC 570550
550	580	22	24	CSC 580550
560	580	15	16	CSC 580560
560	590	22	24	CSC 590560
570	590	15	16	CSC 590570
570	600	22	24	CSC 600570

d _{H9}	D _{H10}	H	E _{+0,2}	ART / ITEM
580	600	15	16	CSC 600580
580	610	22	24	CSC 610580
590	610	15	16	CSC 610590
590	620	22	24	CSC 620590
600	620	15	16	CSC 620600
600	630	22	24	CSC 630600
610	630	15	16	CSC 630610
610	640	22	24	CSC 640610
620	630	7,5	8	CSC 630620
620	650	22	24	CSC 650620
630	660	22	24	CSC 660630
640	670	22	24	CSC 670640
650	680	22	24	CSC 680650
660	690	22	24	CSC 690660
670	700	22	24	CSC 700670
680	710	22	24	CSC 710680
690	720	22	24	CSC 720690
700	730	22	24	CSC 730700
710	740	22	24	CSC 740710
720	750	22	24	CSC 750720



RAD

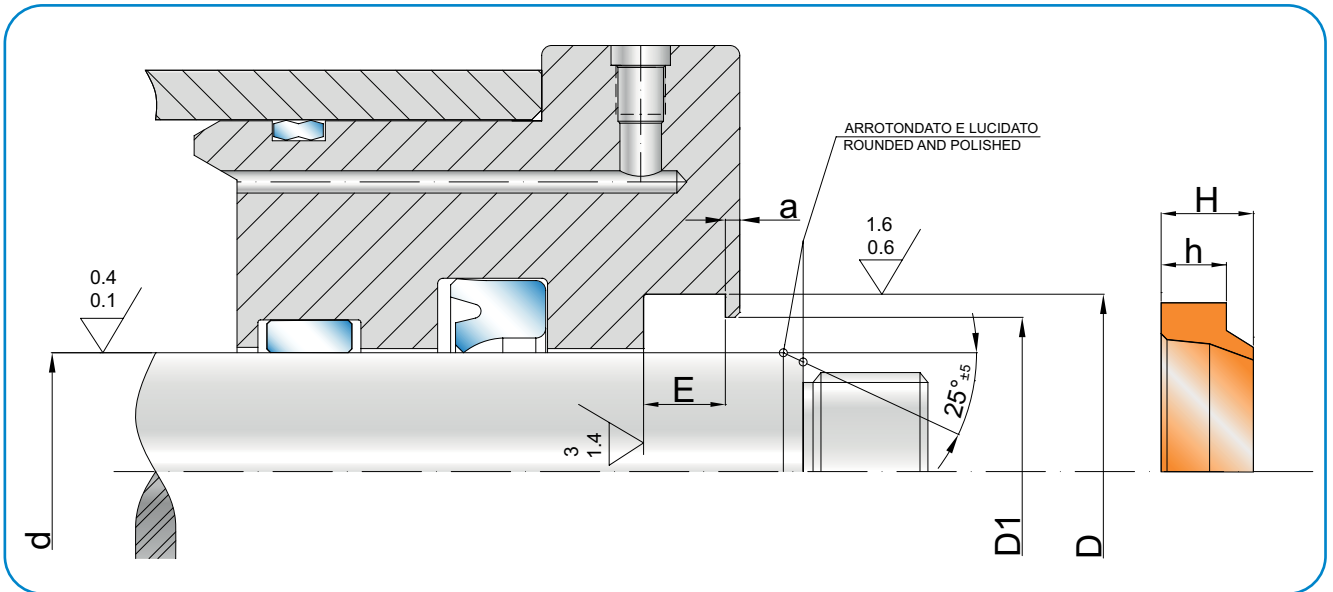
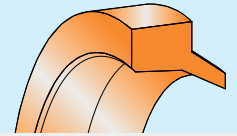

d_{h9}	D_{H10}	$D1$	$E_{+0,2}$	h	H	a	ART / ITEM
250	265,2	258	10,1	10	16	3	RAD 250/5
260	275,2	268	10,1	10	16	3	RAD 260/5
270	285,2	278	10,1	10	16	3	RAD 270/5
275	290,2	283	10,1	10	16	3	RAD 275/5
280	295,2	288	10,1	10	16	3	RAD 280/5
290	305,2	298	10,1	10	16	3	RAD 290/5
300	315,2	308	10,1	10	16	3	RAD 300/5
310	325,2	318	10,1	10	16	3	RAD 310/5





**I prodotti Artic Seals sono distribuiti da:
Artic Seals's products are distributed by:**

GAPI S.p.A.
via Molinaretti, 2
I - 24060 Castelli Calepio (BG) - Italy
ph +39 030 7438 511
fax +39 030 7438 550
sales@gapigroup.com

GAPI Group

Centri di distribuzione e uffici commerciali Sales and logistic centers

GAPI S.p.A.
via Molinaretti, 2
I - 24060 Castelli Calepio (BG) - Italy
ph +39 030 7438 511
fax +39 030 7438 550
sales@gapigroup.com

MIROS s.r.l.
via Gallarate, 221
I - 20151 Milano - Italy
ph +39 02 33 400 480
fax +39 02 33 400 615
e-mail: miros@gapigroup.com

GAPI USA Inc.
300 Huls Drive, Englewood
Ohio, OH 45315, U.S.A.
ph +1 (937) 836-0080
800 442 8030
fax +1 (937) 836-7499
gapi@gapiusa.com

GAPI Ltd
Centurion Business Park
Bessemer Way - Templeborough
Rotherham - Sheffield - S60 1 FB - UK
ph +44 (01709) 378 181
fax +44 (01709) 378 182
sales@gapi.co.uk

GAPI GmbH
Hans Böckler Str. 14
Postfach 200265 - 51503 Rösrath - D
ph +49 (02205) 90494-0
fax +49 (02205) 90494-33
verkauf@gapi.de

Gapi Sealing System S.L.U.
C/ Telecomunicaciones, 21
Polígono Industrial Urtinsa II
28923 Collado Alcorcón (Madrid) - E
ph +34 918517 187
fax +34 918517 195
gapiss@gapiss.es

Stabilimenti di produzione Production plants

GAPI S.p.A.
Rubber Sealing Solutions
via Marconi, 108
24060 Castelli Calepio (BG) - Italy
ph +39 035 847 084
fax +39 035 848 467
gapisede@gapigroup.com

GAPI S.p.A.
Rubber Sealing Solutions
via Molinaretti, 2
24060 Castelli Calepio (BG) - Italy
ph +39 030 7438 511
fax +39 030 7438 550
gapisede@gapigroup.com

GAPI S.p.A.
Rubber Compounds
via L. Da Vinci, 11
24060 Grumello del Monte (BG) - Italy
ph +39 035 4420 880
fax +39 035 4420 432
gapicompounds@gapigroup.com

GAPI S.p.A.
PTFE Products
via Tolari, 12
24060 Gandosso (BG) - Italy
ph +39 035 834 268
fax +39 035 834 275
lanza@gapigroup.com

GAPI S.p.A.
PTFE Sealing Solutions
via Francesca, 19/D
25030 Coccaglio (BS) - Italy
ph +39 030 7701210
fax +39 030 7705721
mg@gapigroup.com

GAPI S.p.A.
PTFE Sealing Solutions
via Europa, 47
25036 Palazzolo s/o (BS) - Italy
ph +39 030 7300221
fax +39 030 7300366
info@fluoril.it

ROLF S.p.A.
Rotary Shaft Seals
via Campania, 24
20093 Cologno Monzese (MI) - Italy
ph +39 02 27 300 700
fax +39 02 25 47 788
rolf@gapigroup.com

ROLF S.p.A.
Hydraulic Sealing Solutions
via Lab. Olivetti, 38
20010 Pregnana Milanese (MI) - Italy
ph +39 02 9359 0625
fax +39 02 9359 0625
rolf@gapigroup.com

PRADELLA & MATEGO S.p.A.
Rubber Sealing Solutions
Regione Crocetta
14018 Villafranca D'asti (AT) - Italy
ph +39 0141 943 544 - 942 061
fax +39 0141 943 046
pradella@gapigroup.com

ARTIC SEALS s.r.l.
Hydraulic Sealing Solutions
via Vettigano, 11
42010 Rio Saliceto (RE) - Italy
ph +39 0522 649 764
fax +39 0522 649 496
info@articseals.it

GAPI GmbH
Technopolymers Sealing Solutions
Hans Böckler Str. 14
Postfach 200265 - 51503 Rösrath - D
ph +49 (02205) 90494-0
fax +49 (02205) 90494-33
verkauf@gapi.de

Index

Rod Seals

Piston Seals

Wipers

Wear Rings

Static Seals

Materials



www.gapigroup.com

